

No. 6284 Chrysler Harmonic Balancer Kit

Use the following steps to remove the crankshaft bolt from the crankshaft damper.

1. Place the pin side of the holding ring into the slots on the crankshaft damper. See Figure 1.
2. Use a 1/2 in. breaker bar to support the holding ring against the crankshaft damper. Place the correct socket with ratchet on the crankshaft bolt. Hold the crankshaft damper and turn the crankshaft bolt counter clockwise to loosen the bolt. See Figure 2.

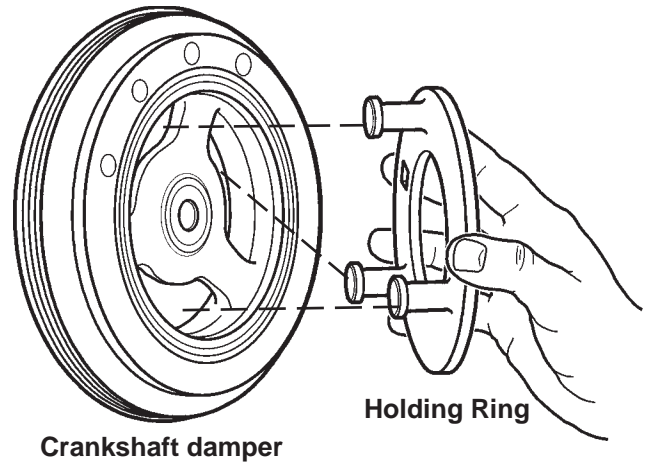

Figure 1

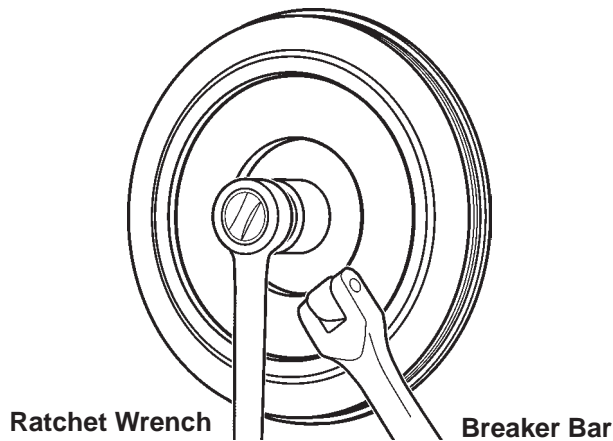

Figure 2

3. Determine which insert will work best to remove crankshaft pulley. Install the appropriate insert into the end of the forcing screw and then into the crankshaft. See Figure 3.
4. Attach the 3-jaw puller to the damper and line up the forcing screw with the insert. See Figure 3.
5. Tighten the forcing screw onto the puller to push against the insert.
6. Remove the crankshaft damper.

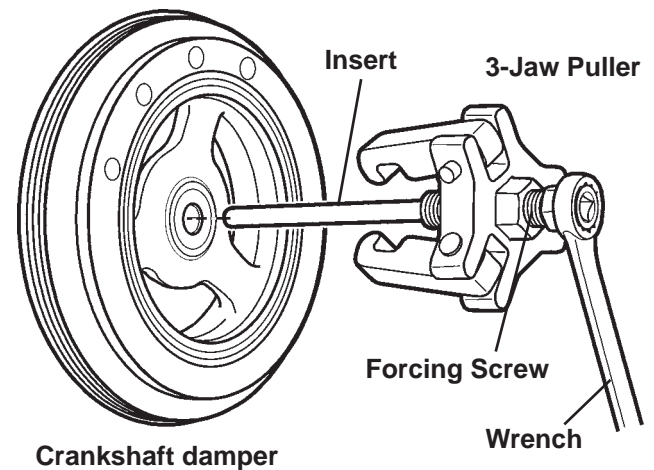
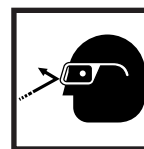

Figure 3



WARNING: To prevent personal injury, wear eye protection that meets ANSI Z87.1 and OSHA standards.