

Tire Bead Seater

Application: Seats tubeless tires in a wide range of sizes.
For example, small ATVs, passenger cars and trucks, heavy-duty vehicles, and agricultural machinery.



*Description:
This equipment uses compressed
air to lift and seal the tire bead to
the wheel rim.*

Explanation of Safety Signal Words

The safety signal word designates the degree or level of hazard seriousness.

! **DANGER:** Indicates an imminently hazardous situation which, if not avoided, will result in death or serious injury.

! **WARNING:** Indicates a potentially hazardous situation which, if not avoided, could result in death or serious injury.

! **CAUTION:** Indicates a potentially hazardous situation which, if not avoided, may result in minor or moderate injury.

CAUTION: Used without the safety alert symbol indicates a potentially hazardous situation which, if not avoided, may result in property damage.

Safety Precautions



CAUTION: To prevent personal injury and/ or property damage,



- Study, understand, and follow all safety precautions and operating instructions before using the Tire Bead Seating Tool. If the operator cannot read instructions, operating instructions and safety precautions must be read and discussed in the operator's native language.
- Only qualified operators may install, operate, adjust, maintain, clean, repair, inspect, or transport this tool.
- Inspect the condition of the tool before each use; do not use if damaged, altered, or in poor condition.



- Wear ear and eye protection that meet ANSI and OSHA standards.
- Do not exceed the maximum air pressure rating of 150 psi. Overfilling the air tank may result in an explosion. Recommended operating air pressure is 90 psi to 140 psi.



- Do not point the air nozzle at a person.
- Hold the nozzle securely against the wheel rim with both hands during the burst of air.
- Discharge the air tank when it is not in use.
- Do not tighten or loosen fittings when the tank is charged.
- Drain the tank periodically, but never remove the drain plug when the tank is charged.
- Do not use this tool for anything other than its intended purpose.
- Do not inflate damaged tires or tires on damaged rims.
- No alteration shall be made to this product.
- Use only those repair parts called out in the parts list in this document. Items found in the parts list have been carefully tested and selected by OTC.

Operating Instructions

1. Position the tire with the narrow bead on top and the tire valve facing up, if possible. It may be necessary to supply air through the valve while seating the bead.
2. Connect shop air to the air fitting on the Tire Bead Seater. The air supply must be clean, dry, oil-free, and regulated.
3. Open the air valve until the gauge on the air tank reads a minimum of 100 psi. Air pressure must be between 90 psi and 140 psi. Close the air valve.
4. Disconnect shop air from the air tank and connect it to the tire valve.
5. Apply tire lubricant around the rim and tire bead.
6. Place the nozzle on the wheel, opposite the tire valve, catching the rim with the two locating bosses on the bottom of the nozzle. See Figure 1.
7. Use the handle on the tank to hold the nozzle on the rim, with the rear of the nozzle tilted at a slight upward angle. The nozzle should not touch the tire sidewall during inflation.
8. Place your other hand on the air valve assembly as shown in Figure 2. Fully open and release the air valve to apply a quick blast of air to seat the tire bead.
9. Completely seat the tire by applying air through the tire valve.

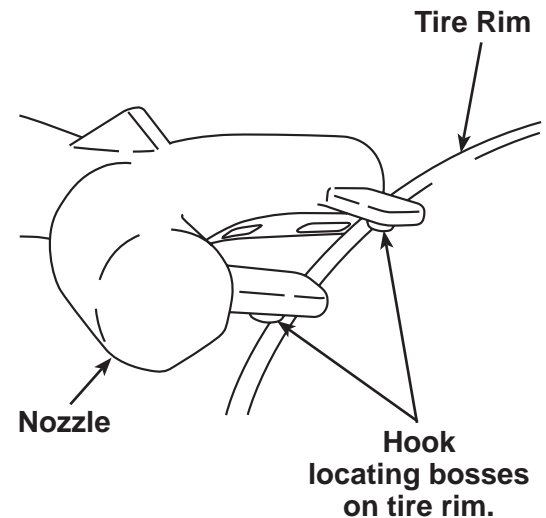

Figure 1

Note: If the valve core was removed, reinstall the valve core and finish inflating the tire to the manufacturer's recommended operating procedure.

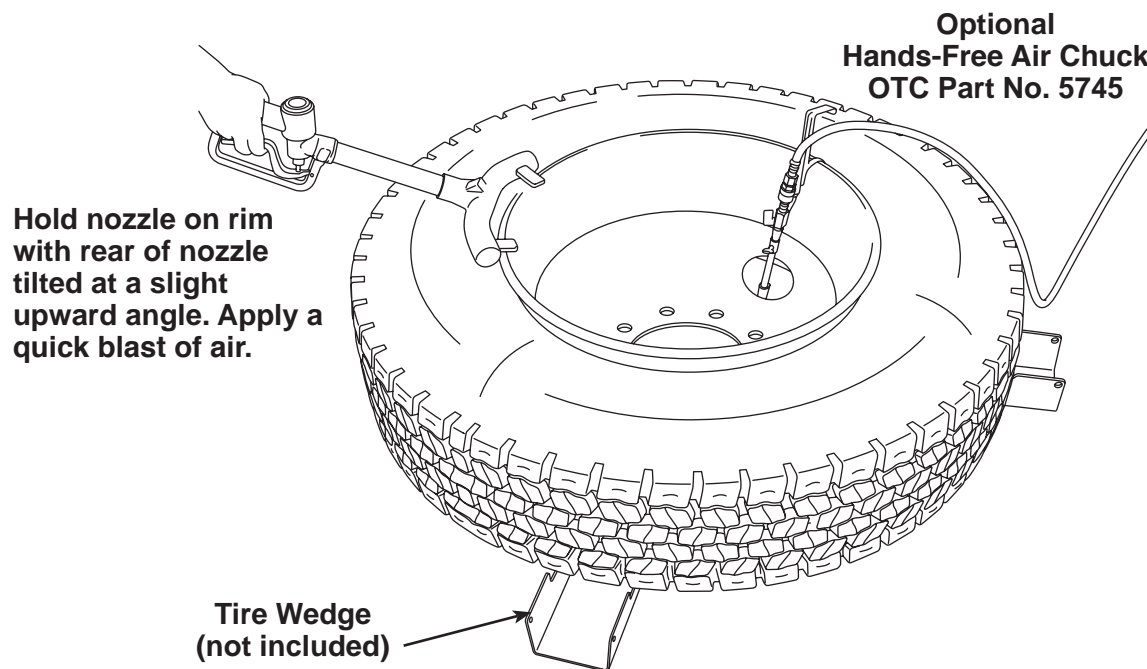
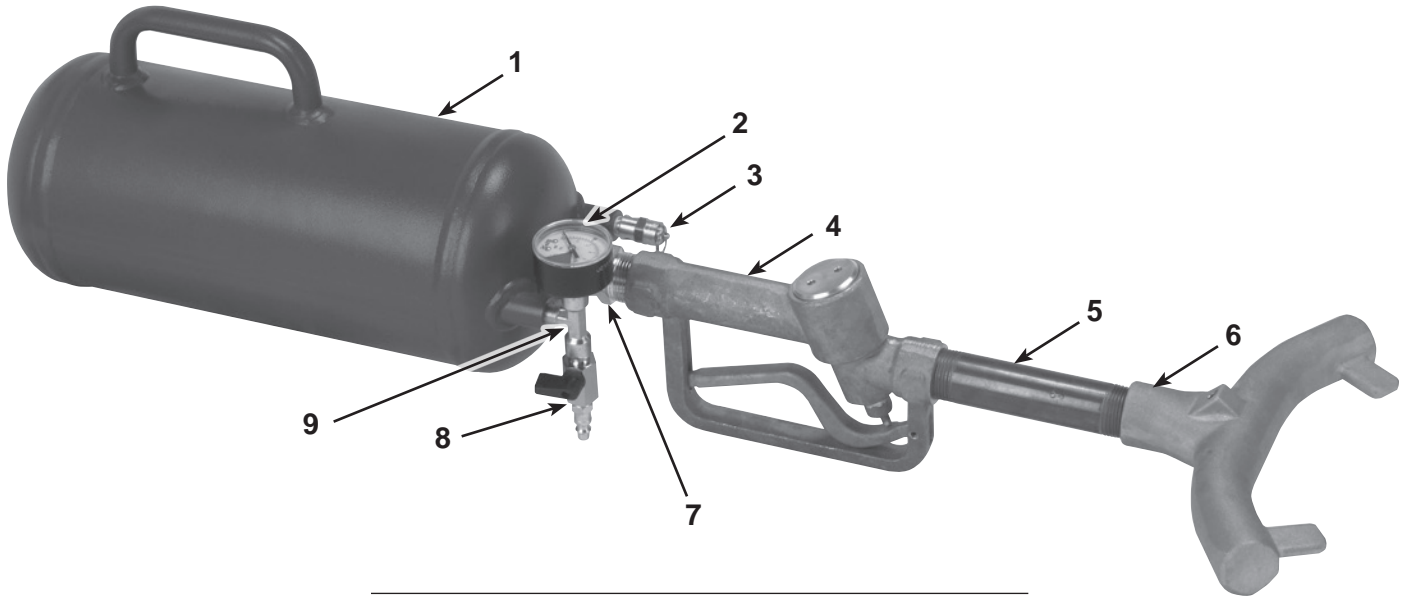

Figure 2

Parts List & Operating Instructions

Replacement Parts List



Item No.	Part No.	Qty.	Description
1	564004	1	Air Tank (2 gallon)
2	560752	1	Pressure Gauge
3	560751	1	Relief Valve (150 psi)
4	562999	1	Air Fill Valve Assembly
5	564007	1	Pipe Nipple
6	563028	1	Nozzle
7	15939	1	Straight Fitting
8	557478	1	Ball Valve (1/4 NPTF)
9	508690	1	Tee Fitting (.25 NPT)

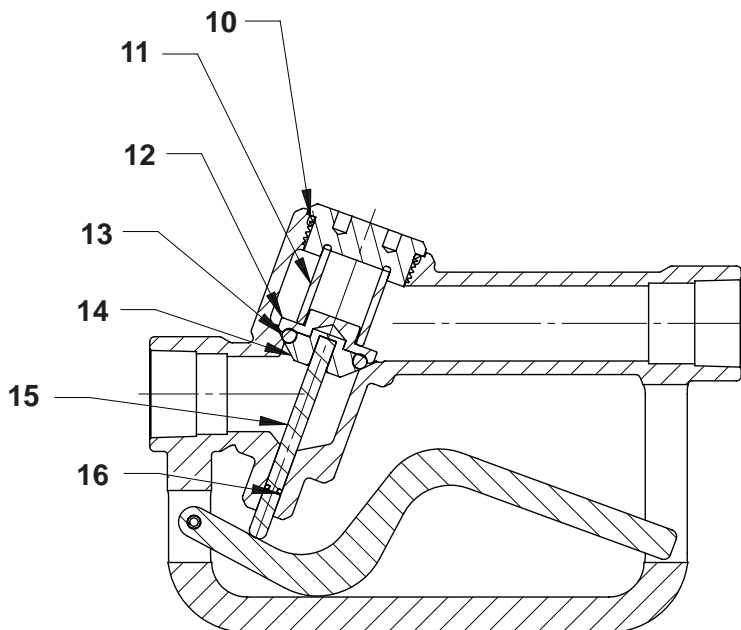

Item No.	Qty.	Description
564161 Air Valve Repair Kit		
10	1	Cap O-ring
11	1	Compression Spring
12	1	Cap
13	1	Seat O-ring
14	1	Seat
15	1	Pump Rod
16	1	Pump Rod O-ring

Inspection and Maintenance



CAUTION: To prevent personal injury,

- Only qualified personnel shall perform inspections and repairs to the Tire Bead Seater.
- Inspect the condition of the tool before each use; do not use if damaged, altered, or in poor condition. If damage is found, discontinue use.
- Use only those repair parts called out in the parts list in this document. Items found in the parts list have been carefully tested and selected by OTC.

Inspection

Before each use, an approved inspector must inspect the condition of the tool; do not use if damaged, altered, or in poor condition. Check the air tank and fitting for cracks. If damage is found, discontinue use.

Maintenance

Store the Tire Bead Seater in the vertical position with the drain plug removed. Never remove the drain plug when the tank is charged. Never store or transport a charged tank.

Repair

When repairing the Tire Bead Seater, use only those repair parts called out in the parts list in this document. Items found in the parts list have been carefully tested and selected by OTC.

Disposal

At the end of the useful life of the Tire Bead Seater, dispose of the components according to all state, federal, and local regulations.