

DPF Thermal Processing Unit

*Optional Accessory to the
Diesel Particulate Filter (DPF) Cleaner*



This user manual provides instructions to treat diesel particulate filters (DPFs) that are full of soot and, therefore, difficult to process through a DPF Cleaner. The procedure described in this manual converts the soot to ash, making the DPF easier to clean.

- DPFs should be inspected using appropriate OE technical procedures.
- The DPF housing **must** be free of dents.
- The DPF ceramic filter **must** be free of cracks or damage.
- This process is not designed for DPFs that are plugged as a result of excessive fluids in the exhaust system, such as coolant, fuel, or oil.
- OTC is not liable for a pre-existing condition in the DPF that would render the filter unstable.

**Particulate filters that do not pass these criteria
should not be treated.**

Explanation of Safety Signal Words



WARNING: Indicates a potentially hazardous situation which, if not avoided, could result in death or serious injury.



CAUTION: Indicates a potentially hazardous situation which, if not avoided, may result in minor or moderate injury.

CAUTION: Used without the safety alert symbol indicates a potentially hazardous situation which, if not avoided, may result in property damage.

Table of Contents

Safety Precautions

Explanation of Safety Signal Words	4
--	---

Initial Setup

Location	5
Unpack the DPF Thermal Processing Unit	5
Electrical Supply	5
Connect the Shop Exhaust System	6
Electrical Connections	6
Control Panel	6

Operation

Load the DPF	7
Operating the DPF Thermal Processing Unit	8
Pre-Treatment Cycle	8
Regeneration Cycle	8
If it is Necessary to Stop a Cycle	9
Door Lock Switch	10
Completion of a Cycle	10
Storage	10

Maintenance

Cleaning the Inside of the DPF Thermal Processing Unit	11
Cleaning the Outside of the DPF Thermal Processing Unit	11
Power Cord	11
Repairing Firebricks	12
Replacing a Thermocouple	12
Replacing Heating Elements	12

Replacement and Optional Parts	13
---	-----------

Important Safety Instructions

Warning

Ash produced by diesel particulate filters has been declared a hazardous waste in some areas of the United States. Follow federal, state, and local procedures for the handling and disposal of ash.



To prevent personal injury when using the DPF Thermal Processing Unit :

- Read, understand, and follow all instructions before operating this device. If the operator cannot read these instructions, operating instructions and safety precautions must be read and discussed in the operator's native language.
- Wear eye protection that meets ANSI Z87.1, CE EN166, AS/NZS 1337, and OSHA standards. If there is eye contact with the ash, flush eyes with cold water for 30 minutes.
- Operate the unit in an area where there is adequate ventilation. Wear a dust mask (rated N95) to avoid breathing the ash. Vacuum the thermal unit using a HEPA-filtered vacuum cleaner.
- Wear thermal gloves that meet OSHA standards. If there is skin contact with the ash, thoroughly wash the skin with soap and water. Do not touch the outer surfaces of the unit during a cycle.
- **RISK OF EXPLOSION.** This equipment has internal arcing or sparking parts which should not be exposed to flammable vapors. Do not locate the unit in a recessed area or below floor level.
- **RISK OF FIRE.** An extension cord may overheat, resulting in a fire. Do not use an extension cord, modify the power cord, or modify the plug.
- **RISK OF FIRE.** Do not operate the unit with a damaged cord – or if the unit has been damaged – until it has been examined by a qualified service person.
- **RISK OF FIRE.** Unplug unit from electrical outlet when not in use. Never use the cord to pull the plug from the outlet. Grasp plug and pull to disconnect.
- **RISK OF FIRE.** Allow more than 305 mm (12 inches) of clearance between the unit and surrounding walls or combustible surfaces. Do not remove the unit from its stand.
- **RISK OF FIRE.** Do not operate the unit in the vicinity of open containers of flammable liquids (gasoline). Store a Class C fire extinguisher nearby.
- **RISK OF FIRE.** Do not open the door to the chamber during a cycle. Do not defeat the door lock or open the door to the chamber if the internal unit temperature is greater than 93°C (200°F).
- **RISK OF FIRE.** Process only one diesel particulate filter (DPF) during a cycle.
- **RISK OF FIRE.** Use replacement fuses having the same amperage and voltage as the original.
- **RISK OF ELECTRICAL SHOCK.** High voltage electricity inside the unit carries a risk of electrical shock. Do not touch heating elements. Unplug the unit before beginning any service work. Incorrect use or connections can cause electrical shock.
- **RISK OF ELECTRICAL SHOCK.** Do not use the unit on wet surfaces or expose the unit to rain.
- Use only genuine repair parts, which are listed in this manual.
- Use the DPF Thermal Processing Unit only for the purpose of which it was designed. Using the DPF Thermal Processing Unit for any other purpose is prohibited.

Save These Instructions

Initial Setup

No. 5281 DPF Thermal Processing Unit is designed to thermally regenerate diesel particulate filters (DPFs) for the purpose of converting the soot contained in the filter to ash. Once this has been accomplished, a DPF cleaner, such as No. 5280, can be used to remove the ash more effectively.

Location

1. Choose a suitable location to set up the DPF Thermal Processing Unit.
 - A. The area must have a concrete floor (no carpet or linoleum) and be large enough to avoid heat buildup around the unit. Allow more than 305 mm (12 inches) of clearance between the unit and surrounding walls or combustible surfaces.
 - B. The unit must sit level on the bare concrete floor; use shims if needed to level the unit.

CAUTION: Installing the unit on an unlevel floor can stress the firebricks inside the chamber, causing breakage.
 - C. There must be an active smoke alarm in the room.
 - D. Sprinkler heads in the vicinity of the unit should be either high-temperature or the type that senses smoke rather than heat.

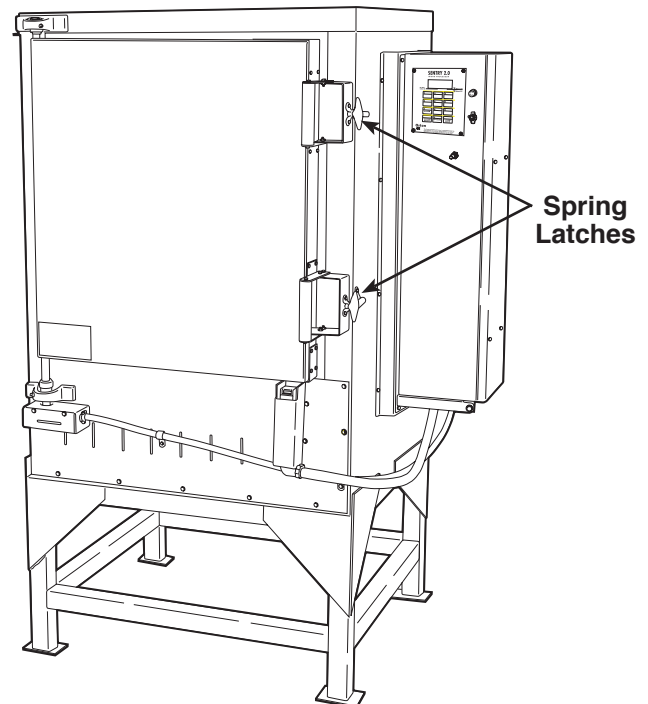

Figure 1

Unpack the Unit

1. Uncrate the unit and remove the shipping materials.
2. Release the spring latches on the door to the firing chamber (see Figure 1), and remove the shipping material from inside the chamber.
3. Remove flammable materials from the room.

Electrical Supply

This unit requires a dedicated electrical circuit. Comply with all state and local electrical codes.

1. Position the unit near a dedicated 240 VAC, single-phase, 50 amp, electrical outlet.
2. The breaker panel for the outlet must be no less than 1.2 m (4 feet) and no more than 7.62 m (25 feet) away from the unit.



WARNING: To prevent personal injury, never place extra insulation around the unit in an attempt to conserve energy. The extra insulation could cause the wiring and case to overheat, resulting in a fire.

Initial Setup

Connect the Shop Exhaust System

The vent system on the back of the unit pulls heated air from the unit, dilutes the heated air with fresh air from the room, and exhausts the air out the 102 mm (4-inch) exhaust port on the back of the unit.

The vent system is activated when the internal temperature of the unit is greater than 93°C (200°F).

1. Connect shop exhaust to the standard 102 mm (4-inch) connection on the bottom of the vent system. See Figure 2.

Electrical Connections

1. Connect the power plug from the vent system to the outlet on the control box. See Figure 2.
2. Connect the power plug from the unit to a dedicated 240 VAC, single-phase, 50 amp, electrical outlet.

Avoid running the power supply cord close to the side of the unit. The high temperature of the unit could damage the cord insulation.

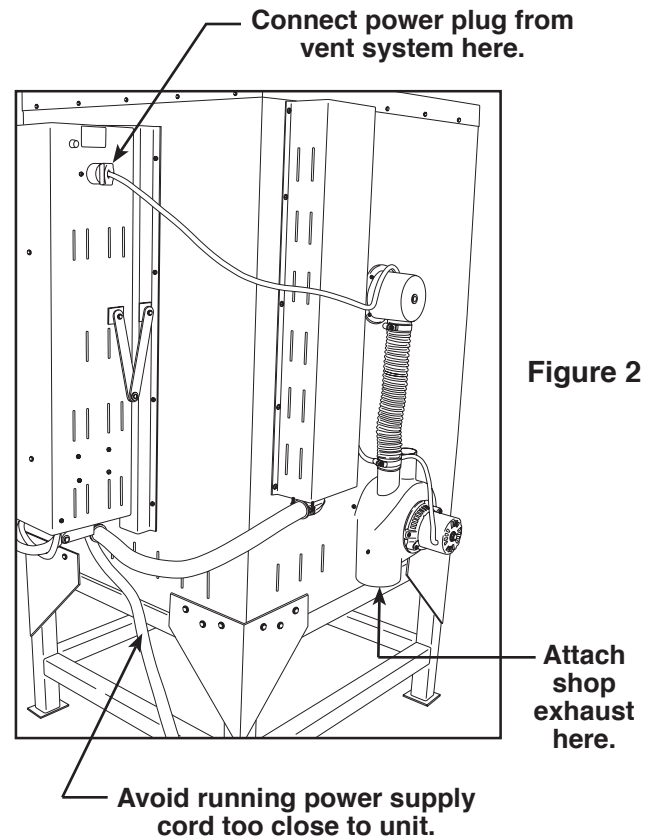

Control Panel

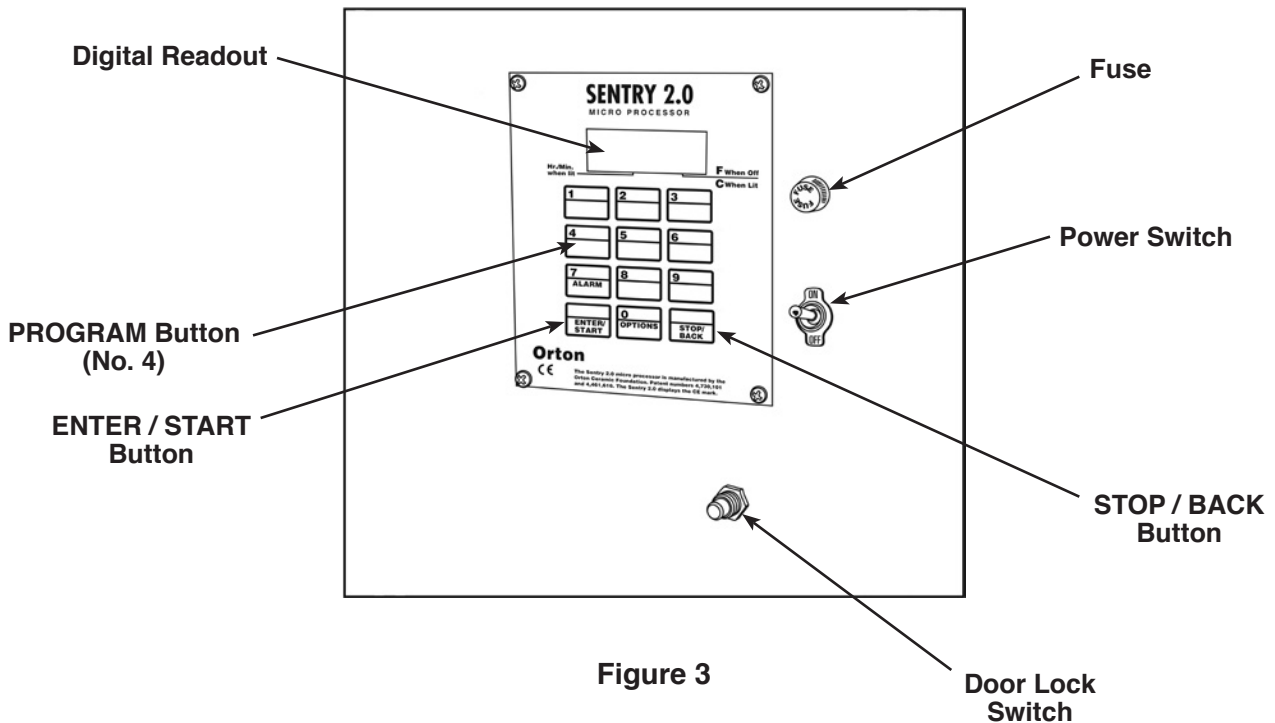

Load the DPF

1. Turn ON the power switch on the control panel. See Figure 3.

The unit emits one tone (beep), and the word IDLE appears on the digital readout. After approximately one minute, the current temperature in the chamber is displayed.

2. Press the door lock switch to unlock the door to the chamber.
3. Position the ceramic shelf on the floor of the unit, and place the stainless steel tray over the ceramic shelf. See Figure 4.
4. Remove any sensors or other temperature-sensitive components from the DPF.
5. Place the DPF on the chamber floor. If positioning the DPF vertically, place heat-resistant blocks or shims under it to allow airflow through the DPF. See Figure 5.

CAUTION: To prevent damage to the unit or the DPF,

- The DPF must be free of dents, cracks, or other damage.
 - When loading a DPF, avoid touching the sidewall firebrick of the chamber.
 - Keep the DPF at least one inch away from the thermocouple (temperature sensor) and the heating elements. See Figure 6.
 - Load only one DPF at a time. Do not attempt to process multiple DPFs.
6. Gently close the door to the chamber. Slamming the door can crack the firebricks.

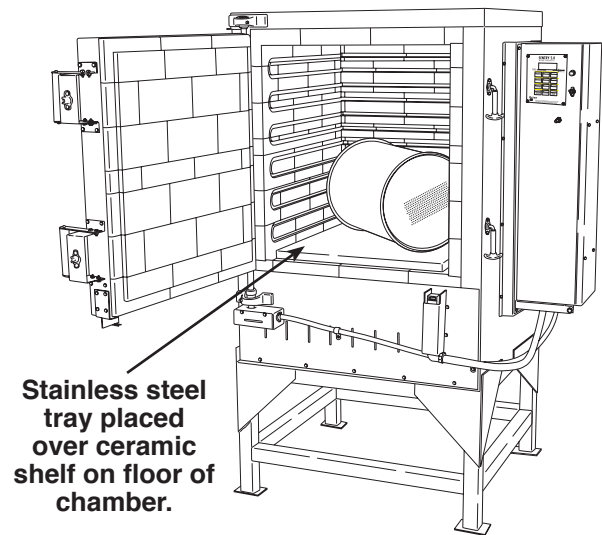

Figure 4

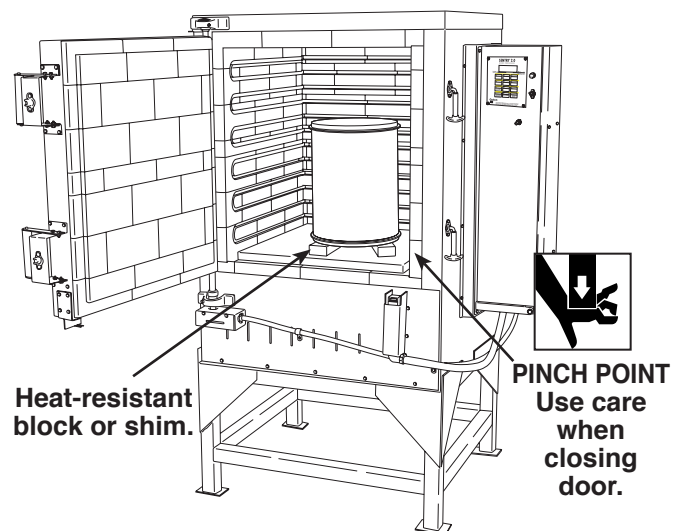

Figure 5



WARNING: To prevent personal injury, verify the thermocouple (temperature sensor) is in place as shown in Figure 6. If the thermocouple has receded into the chamber wall or has been damaged, the chamber could overheat, resulting in a fire.

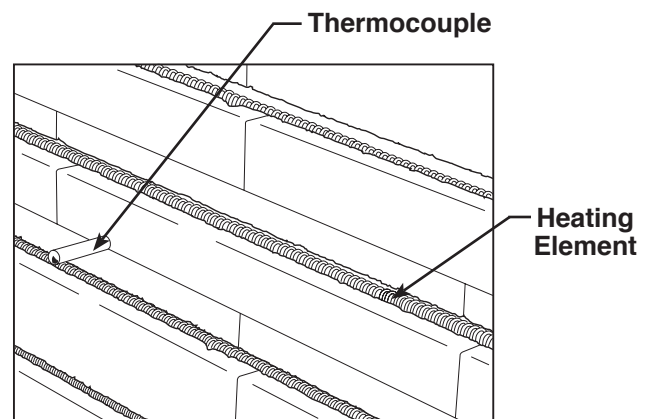

Figure 6

Operation

Operating the DPF Thermal Processing Unit

The DPF Thermal Processing Unit is programmed to control the temperature in the chamber at a rate that will not crack the substrate of the DPF. When the cycle is complete, the program decreases temperature at a controlled rate. The entire cycle takes about fifteen hours.

Note: The DPF Thermal Processing Unit has been pre-programmed for this application, and the program cannot be altered by the user.

Regeneration Cycle (mandatory)

The Regeneration Cycle is used to clean all DPFs, including those filters that have been prepared by using the Pre-Treatment Cycle.

1. After the DPF has been loaded into the unit according to the instructions outlined in *Load the DPF*,

Press

2. The word USER appears on the display.

Press

Three LEDs beside the digital readout either illuminate or pulse on and off. The heating coils inside the chamber are energized, and the digital readout changes to show the increasing temperature inside the chamber.

Pre-Treatment Cycle (optional)

The Pre-Treatment Cycle prepares a DPF for regeneration by burning off excess soot and other unburned hydrocarbons at a lower temperature, which minimizes the risk of fire.

Unburned hydrocarbons will be visible on the surface of the DPF as liquids, oils, or greasy solids. The Pre-Treatment Cycle is provided to prepare DPFs that are heavily laden with soot and other unburned hydrocarbons before the Regeneration Cycle.

Note: DPFs that undergo the Pre-Treatment Cycle must then undergo the Regeneration Cycle. The Pre-Treatment Cycle alone is not sufficient to clean a DPF.

Note:

- *Normal noises during operation include a clicking sound when relays and switches cycle off and on, and a humming sound made by the vibration of the heating elements.*
- *Hairline cracks in the firebrick are normal. The cracks function as expansion joints, expanding and contracting as the unit cools and heats.*



WARNING: To prevent personal injury,

- **RISK OF FIRE.** Carefully touch the power cord while the thermal unit is operating. It is normal for the power cord to feel warm to the touch, but if it feels hot, immediately turn OFF the unit and have an electrician inspect the circuit.
 - **RISK OF FIRE.** Do not open the door to the chamber during a cycle. Opening the door allows hot air to escape and, under certain conditions, could cause a fire.
 - **RISK OF FIRE.** This process is not designed for DPFs that are plugged as a result of excessive fluids in the exhaust system, such as coolant, fuel, or oil.
 - **EXCESSIVE SMOKE.** If excessive smoke is seen escaping from the chamber, STOP THE CYCLE AND VENTILATE THE AREA. Keep the chamber door shut, and turn the unit OFF.
-

Pre-Treatment Cycle continued

1. After the DPF has been loaded into the unit according to the instructions outlined in *Load the DPF*,

Press

The word USER appears on the display.

Press

This cycle takes about 12 hours.

2. After the Pre-Treatment Cycle is complete, use the Regeneration Cycle to finish regenerating the DPF.

If it is Necessary to Stop a Cycle

There are two ways to stop a cycle:

- Press **STOP / BACK**.
ABRT appears on the digital display. The unit may be restarted again by pressing **ENTER / START**.
- Turn OFF the power switch.



 **WARNING:** Opening the chamber door during a cycle allows hot air to escape and, under certain conditions, could cause a fire. These conditions may include an oil soaked DPF or operating the unit in a location that contains flammable materials.

CAUTION: To prevent damage to the DPF,

- Do not stop a cycle by disconnecting the power. Under certain conditions, the controller interprets a power interruption as a power failure and will turn the unit back on when power is reconnected.
- Do not open the door to the chamber during a heating procedure. Opening the door can cause thermal shock by cooling a hot DPF too rapidly, resulting in cracks.

Operation

Door Lock Switch

The DPF Thermal Processing Unit is designed with a feature that locks the chamber door when the internal temperature is greater than 93°C (200°F).

This feature is designed to prevent personal injury from fire, as well as damage to the DPF. If the chamber door is opened at temperatures over 93°C (200°F), the DPF could crack due to uncontrolled, rapid cooling known as thermal shock.

In severe cases, opening the door could result in a fire if the DPF contains a large amount of unburned hydrocarbon.

1. If the chamber door must be opened, and the internal temperature shown on the control panel is less than 93°C (200°F), press **STOP / BACK**. Press the door lock switch on the control panel to open the door. See Fig. 7.

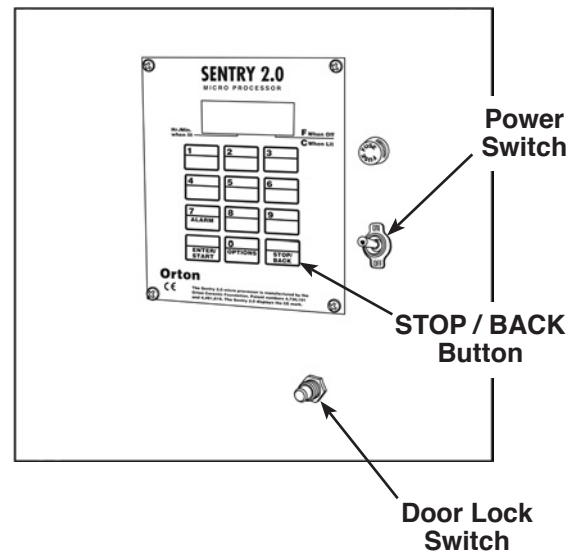

Figure 7

Completion of a Cycle

1. When the cycle is complete, CPLT appears on the digital readout, and the electronic controller turns off the thermal unit.

Do not open the door until the digital readout on the control panel displays room temperature.

2. Manually turn OFF the power switch.

Storage

1. When the unit is not in use, close the door to the chamber and unplug the power cord from the wall socket.

 **WARNING:** To prevent personal injury, turn all switches to OFF and disconnect the power cord from the wall socket before performing maintenance on the DPF Thermal Processing Unit.

Cleaning the Inside of the Unit

After each procedure, carefully vacuum the inside of the chamber to remove soot, ash, and firebrick dust.

1. Disconnect power to the unit to avoid possible damage to the electronics due to static electricity.
2. Wear a dust mask (rated N95), gloves, and eye protection to protect yourself from the soot and ash.
3. Vacuum the inside of the unit using a soft attachment attached to a HEPA-filtered vacuum cleaner. The soft attachment is necessary to prevent damage to the firebrick.
4. Carefully vacuum the element grooves without touching the heating elements. Do not touch the thermocouple.

Cleaning the Outside of the Unit

Wipe off the outside of the thermal unit using a glass cleaner. Avoid spraying cleaner on the control box or inside the unit.

Power Cord

Regularly examine the power cord and plug for frays, tears, or other damage. Never remove a plug from a socket by pulling on the cord. Damaged electrical cords can result in electrical shock or a fire hazard.

If you smell burning plastic, immediately turn OFF the unit and examine the wall outlet and power cord.

 **WARNING:** To prevent personal injury, carefully touch the power cord while the DPF Thermal Processing Unit is operating. It is normal for it to feel warm to the touch, but if it feels hot, immediately turn OFF the unit and have an electrician inspect the circuit.

Maintenance

Repairing Firebricks

The firebricks around the inside of the unit insulate the firing chamber and support the heating elements.

Hairline cracks in the firebrick are normal. The cracks function as expansion joints, expanding and contracting as the unit cools and heats.

However, **holes** in the firebrick may be patched with repair cement to prevent them from becoming larger. Use a commercially available ceramic cement or a stiff putty made of high-fire wash and water.

CAUTION: Do not touch the heating elements during this procedure. A damaged element could break or burn out the next time it is heated.

1. Carefully vacuum the interior of the unit to remove any soot or ash.
2. Undercut the edges of the area to be filled.
3. Tamp the cement or putty into place.
4. After the spot has dried thoroughly, use 250 grit sandpaper to smooth the cement until it is level with the surface.
5. Vacuum the interior of the unit to remove any cement or putty dust.

Replacing a Thermocouple

A thermocouple sensor may deteriorate over time, resulting in inconsistent heating temperatures.

Replacing a Heating Element

New heating elements look like a tightly wound spring. Used heating elements are dull, dark, brittle, and may break if they are bent when they are cold.

Over time heating elements gradually draw less power and should be replaced.



- WARNING: To prevent personal injury,**
- **Repair all chips and cracks around the chamber door and the door sealing area to reduce the risk of burns and, in extreme cases, fire.**
 - **Do not use the unit if the thermocouple is damaged. A working thermocouple is required to regulate the temperature inside the chamber.**
-

Replacement and Optional Parts

Replacement Parts List

Part No.	Qty.	Description
557231	1	Stainless Steel Tray
557232	1	Ceramic Shelf
557467	1	Thermocouple Replacement Kit
566679	1	Heating Element Kit (<i>top and bottom</i>)

Troubleshooting Guide

Problem	Cause	Solution
DPF Thermal Processing Unit does not consistently reach desired temperature.	<ol style="list-style-type: none">1. The bead on the end of the thermocouple is broken or damaged.2. Heating elements are worn out or damaged.3. Chamber door not closed.	<ol style="list-style-type: none">1. <i>Replace thermocouple.</i>2. <i>Replace heating elements.</i>3. <i>Close chamber door.</i>
Display screen is blank.	<ol style="list-style-type: none">1. No power.	<ol style="list-style-type: none">1. <i>Verify machine is ON, plugged into an outlet, and power is available to the outlet.</i>
Chamber door does not close or open correctly.	<ol style="list-style-type: none">1. Door is not latched.2. Damaged door hinges, seals, or latches.	<ol style="list-style-type: none">1. <i>Verify door is correctly latched.</i>2. <i>Repair damaged door hinges, seals, or latches.</i>