

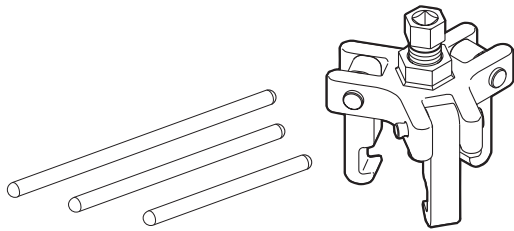

Chrysler Cam Tools Master Set

Operating Instructions

Cam Tool	Part No.	Page
Camshaft Alignment Tools	522888	2
Camshaft Holding Pins	522898	11
Camshaft Sprocket Holder	522889	3
Camshaft Wrench	522894	8
Crankshaft Damper Puller	513990	1
Harmonic Balancer Holding Ring	522891	5
Idler Shaft Remover	522896	9
Secondary Timing Chain Holder	522902	15
Tensioner Lock Pin	522897	10
Timing Belt Tensioner	522899	12
Timing Belt Tensioner Tool	522900A	13
Timing Belt Wrench	522901	14
Timing Chain Tensioner Reset Tool	522890	4
Timing Chain Wedge	522892	6
Timing Chain Wedge	522893	7



No. 513990 Crankshaft Damper Puller

Application : Chrysler vehicles with pressed-on crankshaft dampers

1. Remove the crankshaft damper bolt.
2. Select the appropriate length insert which will bottom in the crankshaft bolt hole.
3. Install the insert into the puller forcing screw.
4. Install the puller assembly onto the crankshaft damper pulley.
5. Tighten the forcing screw to remove the pulley.

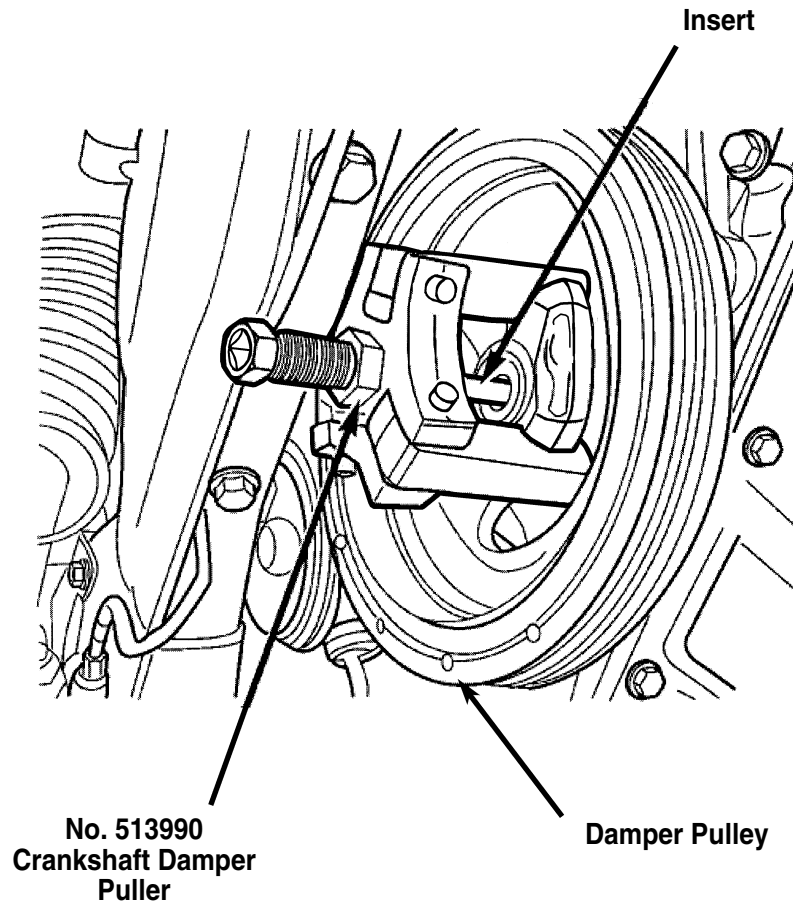

 **CAUTION:** To prevent personal injury, wear eye protection that meets ANSI Z87.1 and OSHA standards.

No. 522888 Camshaft Alignment Tools

Application : 1993–1997 Chrysler Concorde 3.5L V6
1994–1997 Chrysler New Yorker, LHS 3.5L V6
1999–newer Chrysler LHS, 300M 3.5L V6
1993–newer Dodge Intrepid 3.5L V6

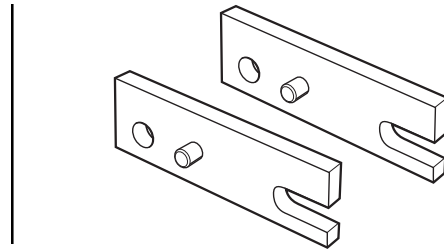

Important: To prevent engine damage, use No. 522888 to set camshaft timing whenever the cam sprockets are loosened or removed.

1. Place the crankshaft sprocket to the top dead center (TDC) mark on the oil pump housing. See Figure 1.
2. Install a dial indicator in the No. 1 cylinder, and rotate the crankshaft until the piston is at exactly TDC.
3. Install the No. 522888 to the rear of each cylinder head. See Figure 2.

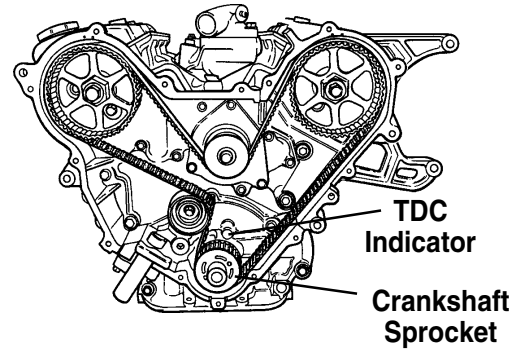

Figure 1

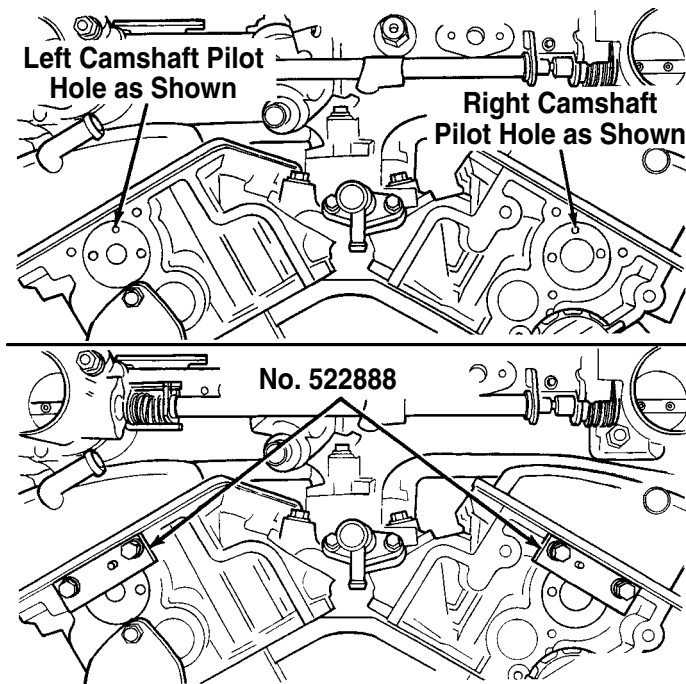

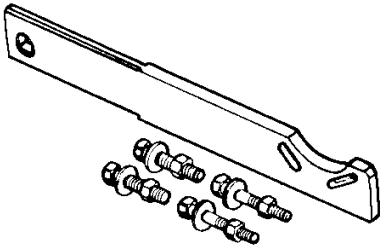

Figure 2

 **CAUTION:** To prevent personal injury, wear eye protection that meets ANSI Z87.1 and OSHA standards.



No. 522889 Camshaft Sprocket Holder

Application : 1995–newer Chrysler Cirrus/Sebring, Dodge Stratus 2.5L V6
1995–1997 Chrysler Cirrus/Sebring 2.4L 4 Cyl.
1995–newer Dodge Stratus 2.4L 4 Cyl.
1997–newer Plymouth Breeze 2.4L 4 Cyl.
1995–1999 Chrysler Cirrus 2.0L 4 Cyl.
1996–newer Chrysler Sebring, Dodge Breeze, Neon VIN Code C

1. Adjust the pins on the No. 522889 Camshaft Sprocket Holder to fit the camshaft sprocket. Use No. 522889 to hold the camshaft sprocket when tightening or loosening the cam sprocket bolt.

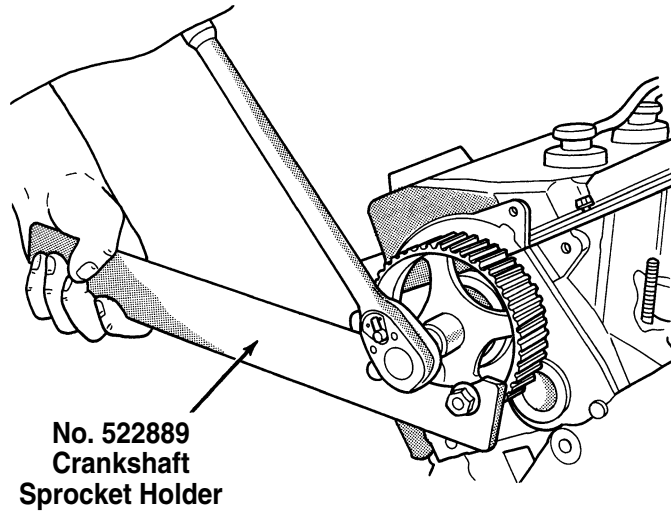

No. 522889
Crankshaft
Sprocket Holder



CAUTION: To prevent personal injury, wear eye protection that meets ANSI Z87.1 and OSHA standards.

No. 522890 Timing Chain Tensioner Reset Tool

Application : 1998–newer Chrysler, Dodge cars with 2.7L V6

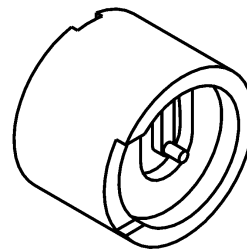

1. Purge engine oil from the tensioner by placing the check ball end of the tensioner into the shallow end of No. 522890, aligning the check ball with the pin in the tool. Using hand pressure, slowly depress the tensioner until the oil is purged.

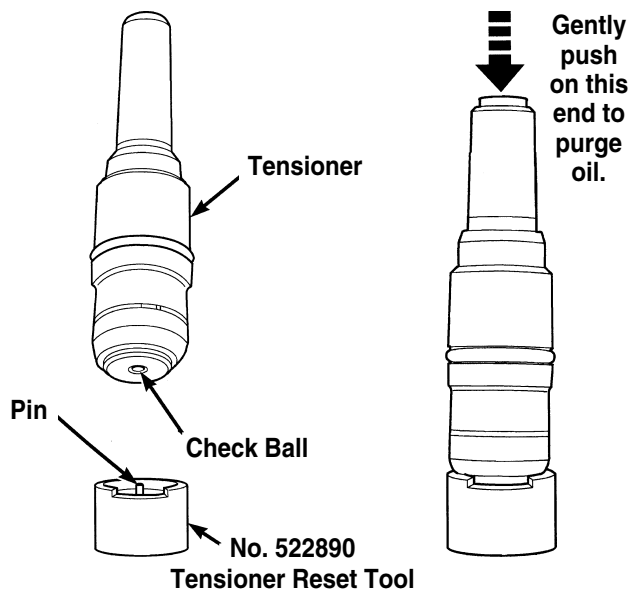

2. Place the cylinder plunger end of the tensioner into the deeper end of No. 522890. Push down on the tensioner until the body bottoms against the top of the tool. **IMPORTANT: Failure to correctly reset the tensioner may cause it to jam.**

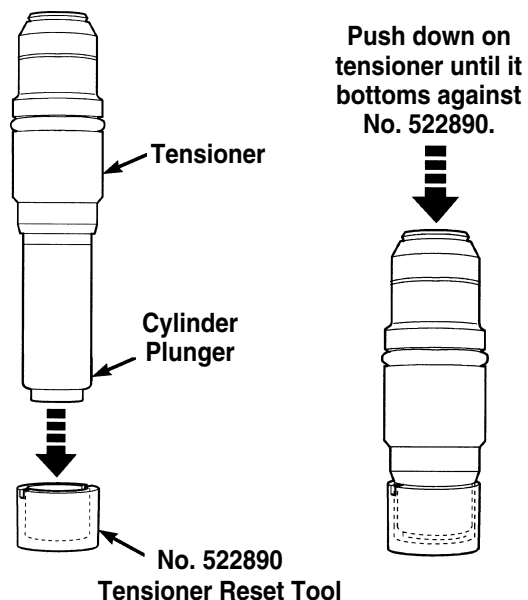

3. Install the reset chain tensioner into the right cylinder head. Refer to the vehicle service manual, and torque the retaining plate to OE specifications.

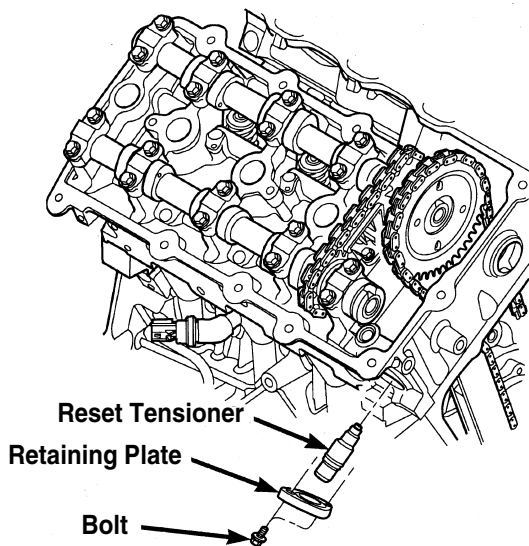

4. Use a flat-bladed pry bar to GENTLY pry the tensioner arm toward the tensioner. Release the tensioner arm, and verify the tensioner is set (extended).

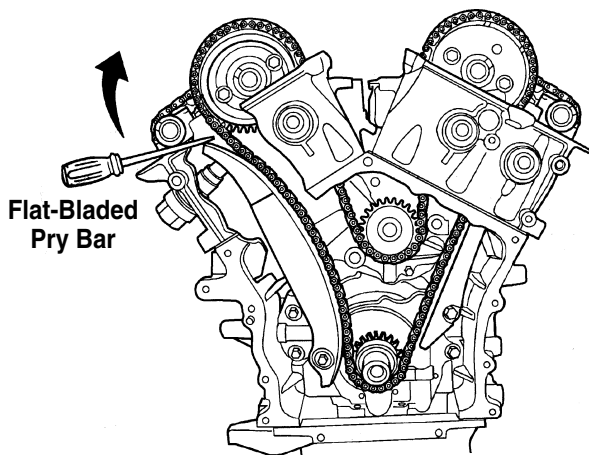

 **CAUTION:** To prevent personal injury, wear eye protection that meets ANSI Z87.1 and OSHA standards.

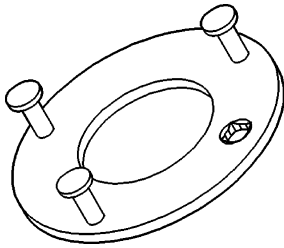

No. 522891 Harmonic Balancer Holding Ring

Application : Chrysler vehicles having a three-slot damper

Use the following steps to remove the crankshaft bolt from the crankshaft damper.

1. Insert the pin side of the No. 522891 through the slots on the crankshaft damper. See Figure 1.
2. Use a 1/2" breaker bar to hold the holding ring against the crankshaft damper. Place the correct socket with ratchet on the crankshaft bolt. Hold the crankshaft damper, and turn the crankshaft bolt counterclockwise to loosen the bolt. See Figure 2.

The holding ring can also be used to tighten the crankshaft bolt to factory torque specifications.

1. Insert the pin side of the holding ring through the slots on the crankshaft damper. See Figure 1.
2. Use a 1/2" breaker bar to hold the holding ring against the crankshaft damper. Place the correct socket with a torque wrench on the crankshaft bolt. Hold the crankshaft damper, and turn the crankshaft bolt clockwise to tighten the bolt to the correct OE torque specifications. See Figure 2.

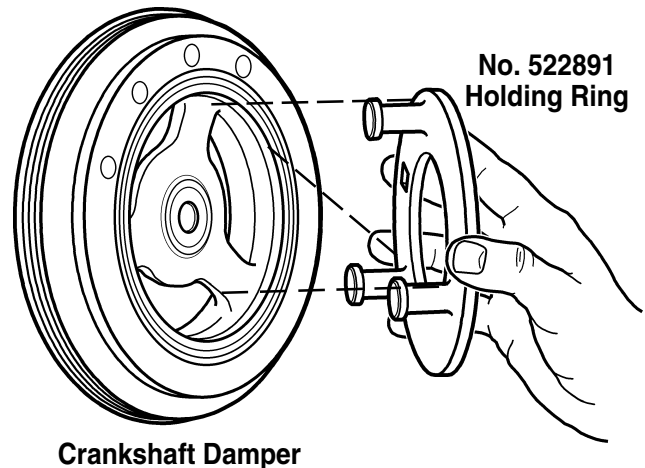

Crankshaft Damper

Figure 1

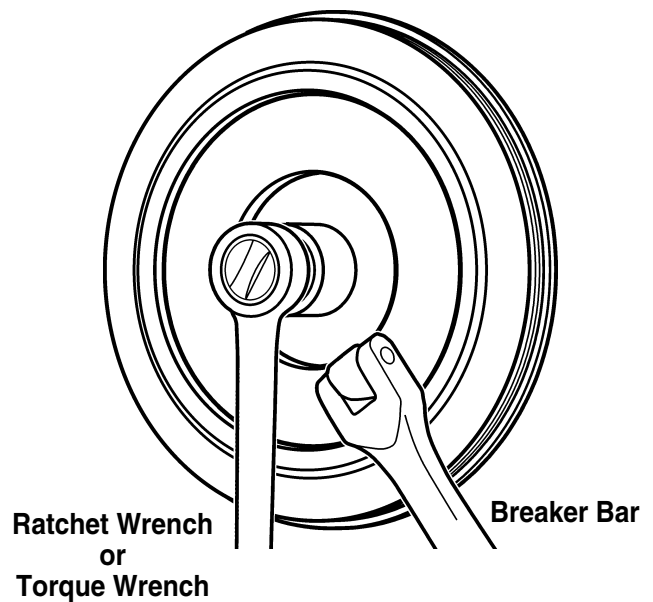

Ratchet Wrench
or
Torque Wrench

Breaker Bar

Figure 2

No. 522892 Timing Chain Wedge

Application : 1999–newer Jeep Grand Cherokee 4.7L V8

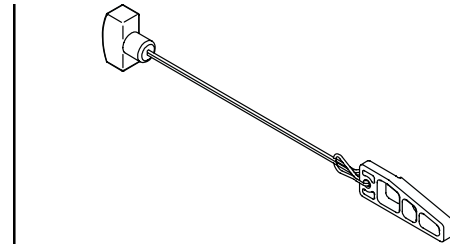

1. Set engine to TDC #1 compression. The cam sprocket "V8" mark should be at the 12:00 o'clock position.
2. Mark one link on the timing chain to the cam sprocket – this will help during reassembly.
3. Position No. 522892 between the timing chains. Tap the tool to securely wedge the timing chain against the tensioner arm and guide.
4. Carefully remove the cam sprocket bolt. The cylinder head and / or valve train are ready for service.

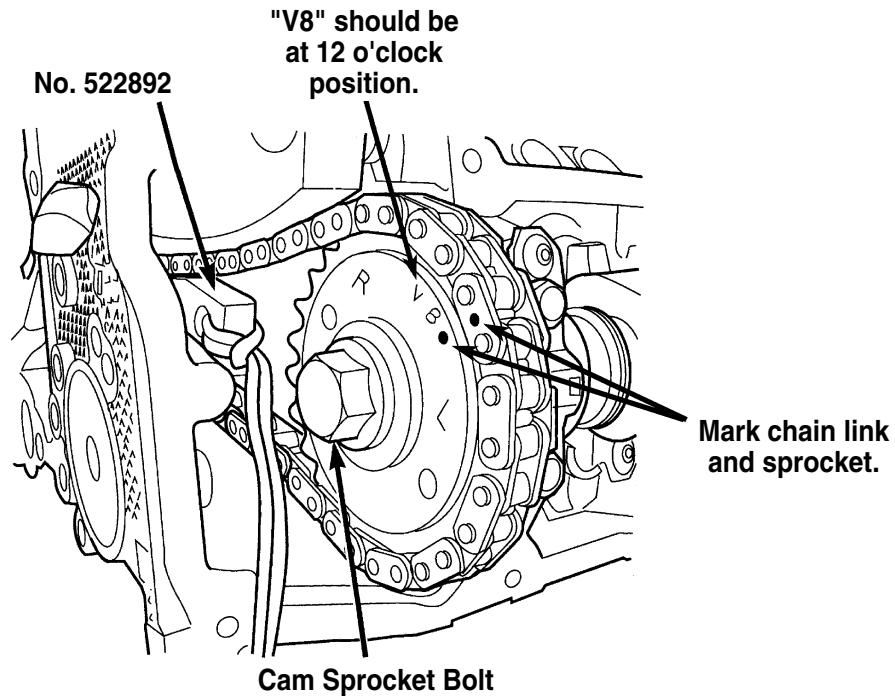

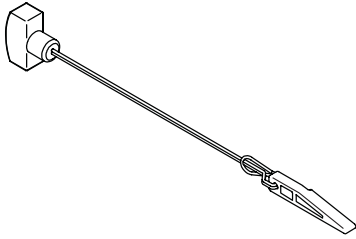

No. 522893 Timing Chain Wedge

Application : 2002–newer Jeep Liberty 3.7L V6

1. Set engine to TDC #1 compression. The cam sprocket "V6" mark should be at the 12 o'clock position.
2. Mark one link on the timing chain to the cam sprocket – this will help during reassembly.
3. Position No. 522893 between the timing chains. Tap the tool to securely wedge the timing chain against the tensioner arm and guide.
4. Carefully remove the cam sprocket bolt. The cylinder head and / or valve train are ready for service.

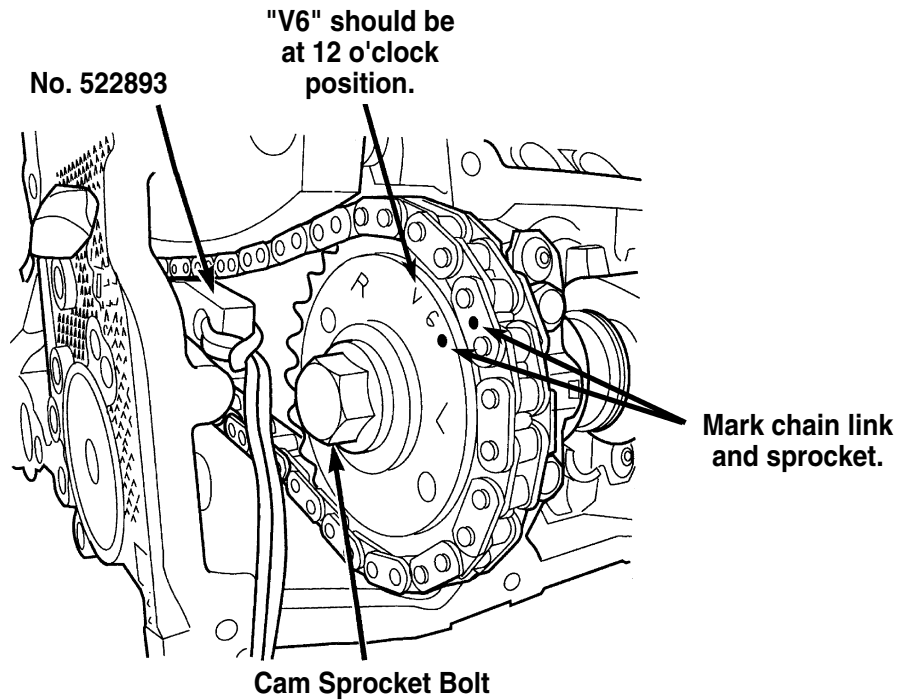

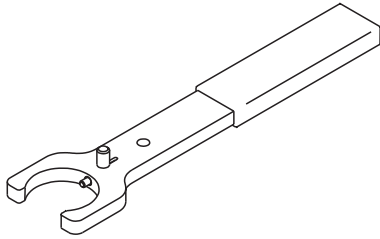

No. 522894 Camshaft Wrench

Application : 2002–newer Jeep Liberty 3.7L V6

1. Place No. 522894 Camshaft Wrench over the camshaft as shown, with the pin in the wrench aligned with the hole in the camshaft.
2. Use the wrench to rotate the camshaft. **Important: The wrench is not designed to hold the camshaft when tightening or loosening the cam sprocket bolt.**

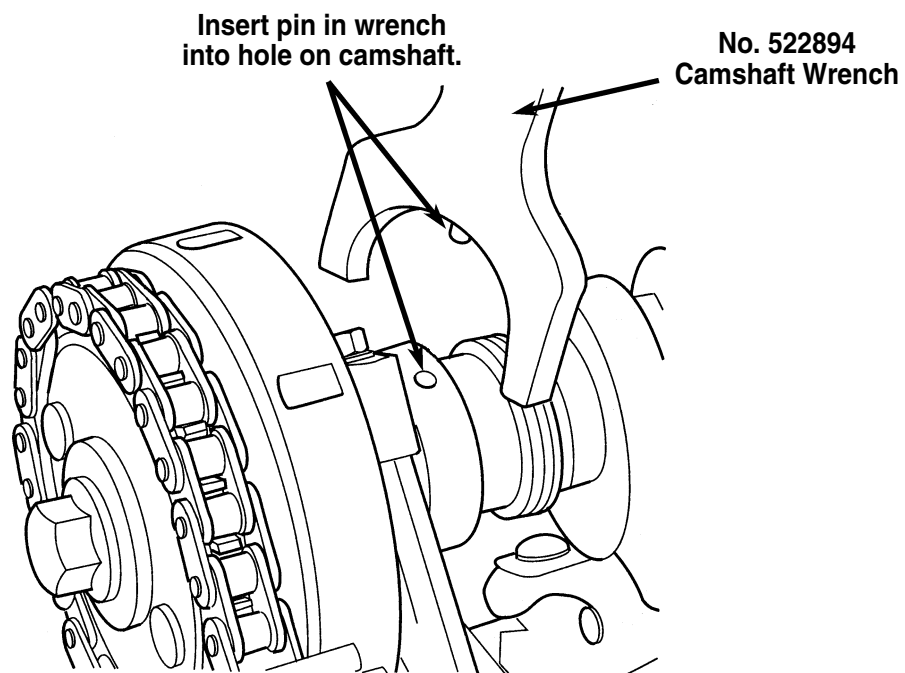

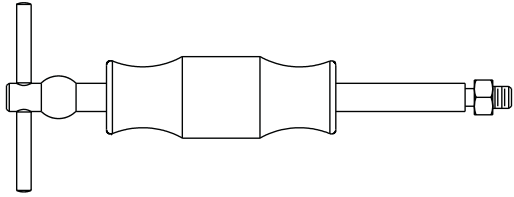

No. 522896 Idler Shaft Remover

Application : 1999–newer Jeep Grand Cherokee 4.7L V8

1. Refer to the appropriate service manual, and remove timing chains and the idler sprocket from the idler shaft according to OE procedures.
2. Thread the No. 522896 Idler Shaft Remover into the idler shaft, and apply the slide hammer to remove the idler shaft from the engine block.

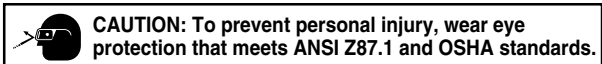

CAUTION: To prevent personal injury, wear eye protection that meets ANSI Z87.1 and OSHA standards.

No. 522897 Tensioner Lock Pin

Application : 1999–newer Jeep Grand Cherokee with 4.7L V8 engine

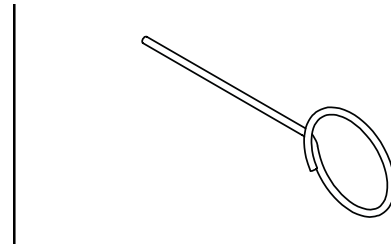

1. Using a vise, lightly compress the chain tensioner piston until the piston step is flush with the tensioner body.
2. Pull back the ratchet pawl —against spring force—through the access hole on the side of the tensioner.
3. While holding the pawl back, push the ratchet device toward the tensioner body, and install the No. 522897 Tensioner Lock Pin through the hole on the side of the tensioner. This releases the ratchet pawl.

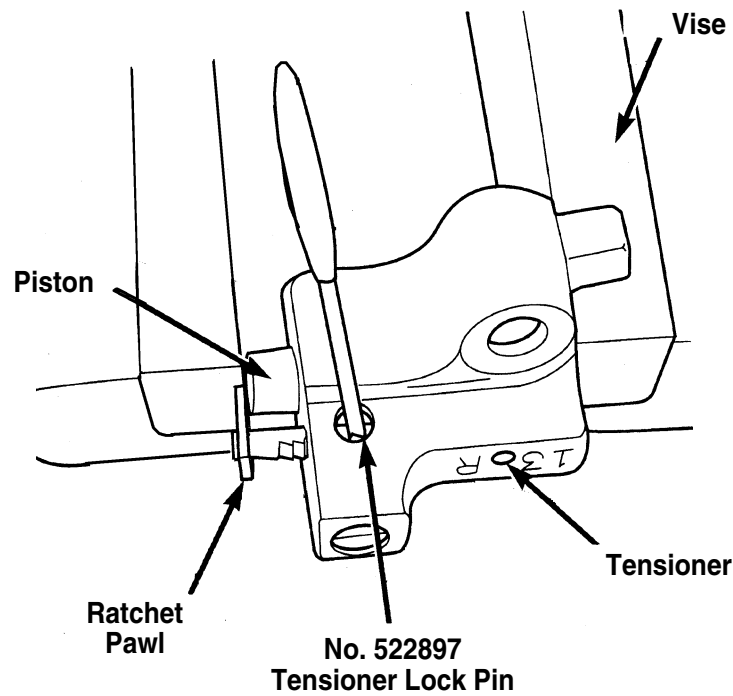

 **CAUTION:** To prevent personal injury, wear eye protection that meets ANSI Z87.1 and OSHA standards.

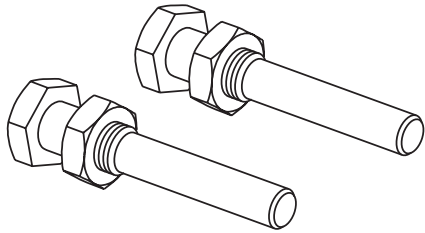

No. 522898 Camshaft Holding Pins

Application : 2001–newer Chrysler vehicles

Note: No. 522898 Camshaft Holding Pins are designed to work with No. 522889 Camshaft Sprocket Holder.

1. Remove the pin from No. 522889 Camshaft Sprocket Holder, and install the No. 522898 Camshaft Holding Pins.
2. Adjust the holding pins to fit the camshaft sprocket.
3. Use the No. 522889 Camshaft Sprocket Holder to hold the cam sprocket when tightening or loosening the cam sprocket belt.

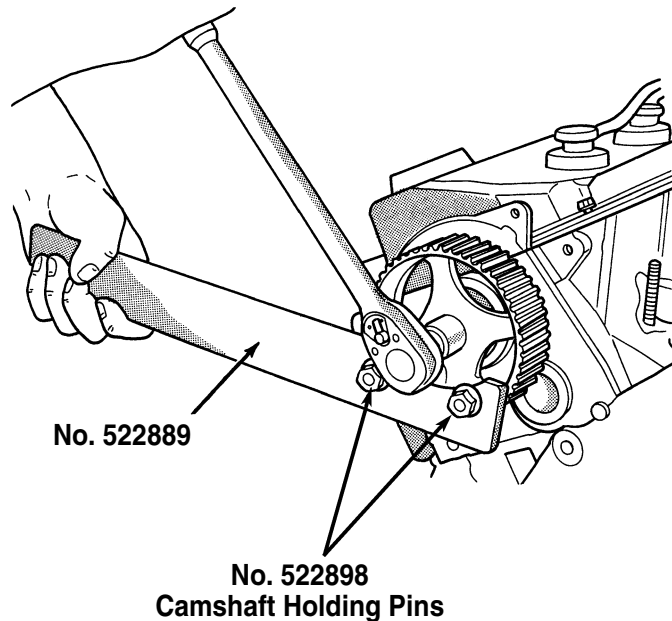

No. 522899 Timing Belt Tensioner

Application : 1981–1999 Chrysler-built 2.2L and 2.5L 4 Cyl. engines

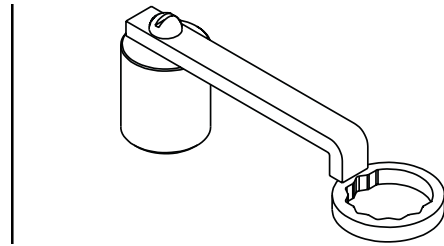

1. Turn the crankshaft and intermediate shaft until the timing markings on the sprockets are aligned.

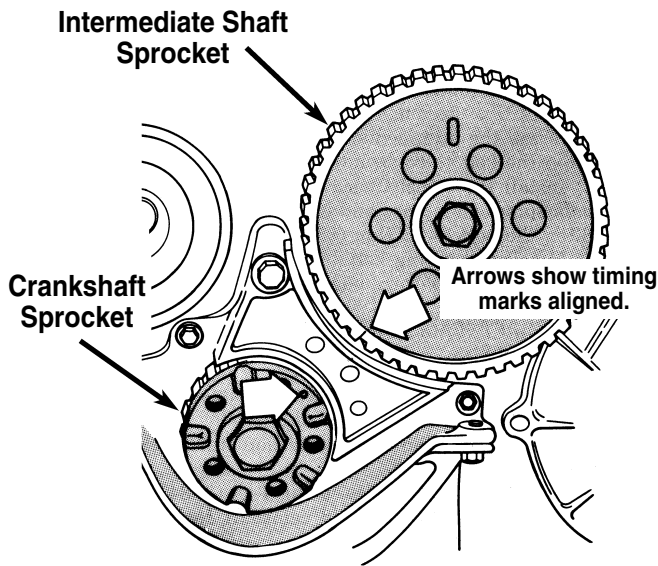

2. Remove the spark plugs from the cylinder head.
3. Turn the camshaft until the arrow on the sprocket is in line with the camshaft cap to cylinder headline.
Note: Small hole in sprocket must be at the top.

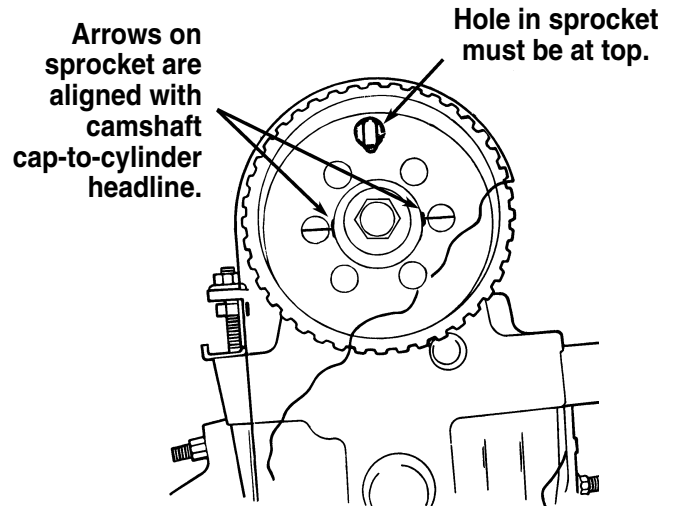

4. Install the timing belt in the following order: crankshaft sprocket; intermediate sprocket; camshaft sprocket; and tensioner.

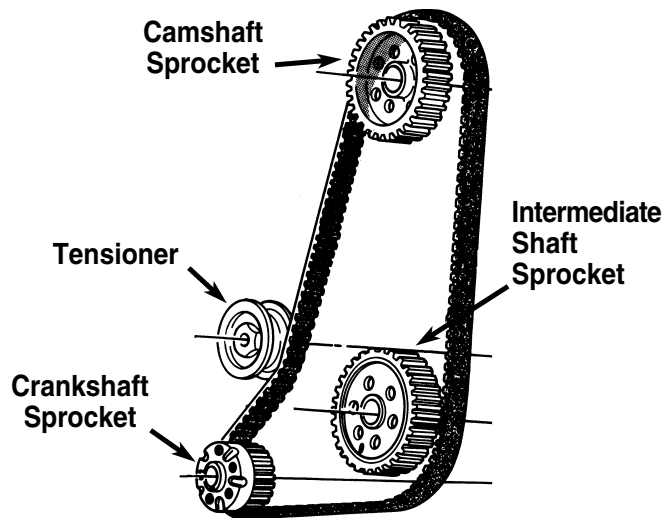

5. Loosen the tensioner bolt. Install No. 522899 on the large hex on the timing belt tensioner, with the tool within 15° of horizontal.
6. Turn the engine clockwise two crankshaft rotations. Hold the tool in place, and torque the tensioner bolt to OE specifications.

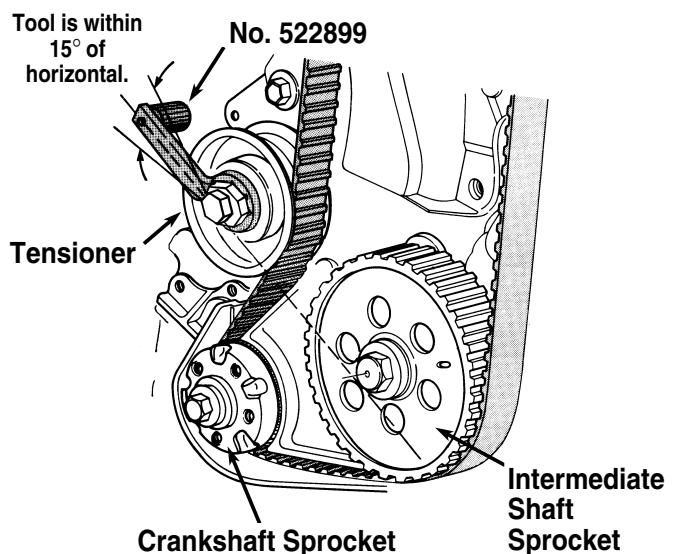

CAUTION: To prevent personal injury, wear eye protection that meets ANSI Z87.1 and OSHA standards.

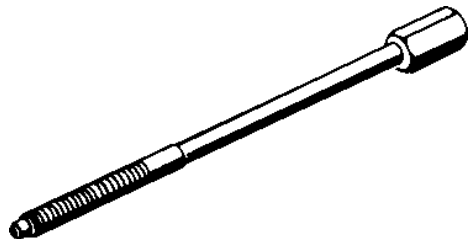

No. 522900A Timing Belt Tensioner Tool

Application : 1989–1995 Colt, Summit with 2.4L 4 Cyl. Mitsubishi Engine

1. Follow the vehicle manufacturer's specifications to assemble and position the timing belt tensioner pulley. See Figure 1.

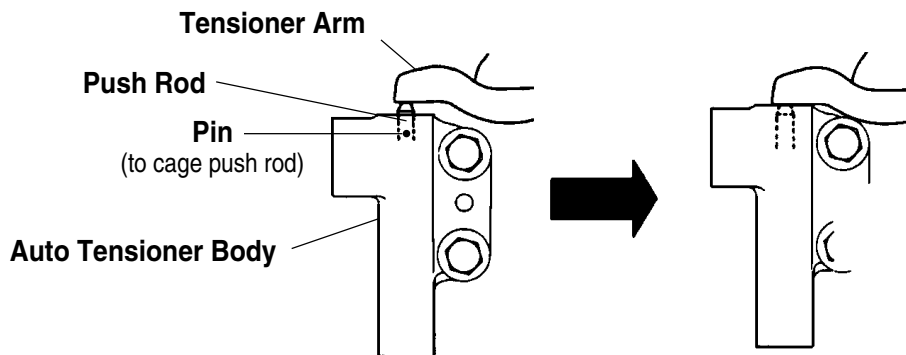

Figure 1

2. Remove the plug in the side cover of the engine. See Figure 2.
3. Insert the No. 522900A Timing Belt Tensioner Tool into the threaded hole in the side cover. See Figure 3.
4. Turn the tensioner tool clockwise until it meets the auto tensioner push rod.
5. Continue turning the tool until you can easily remove the pin that cages the auto tensioner push rod.
6. Slowly back off the tensioner tool until the auto tensioner takes over.
7. Remove the tool from the side cover, and replace the plug.

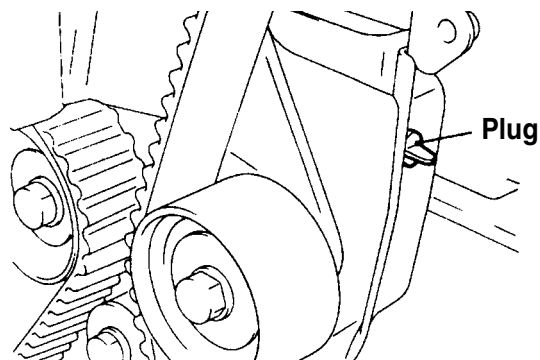

Figure 2

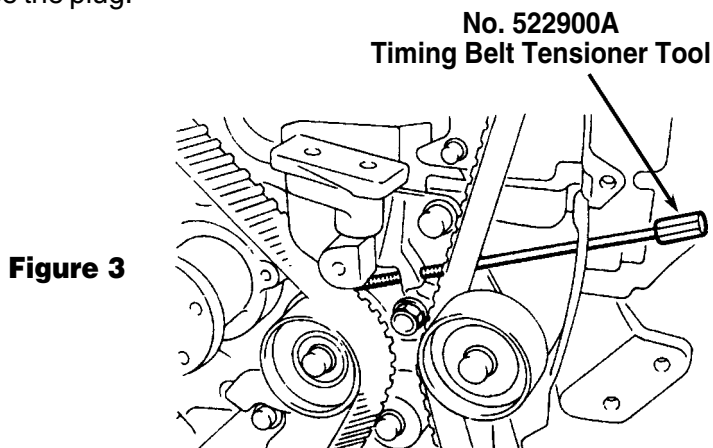

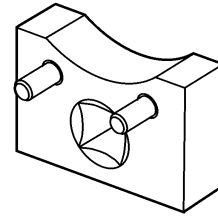

Figure 3

 **CAUTION:** To prevent personal injury, wear eye protection that meets ANSI Z87.1 and OSHA standards.

No. 522901 Timing Belt Wrench

Application : Chrysler vehicles with Mitsubishi engines
1991–1997 Dodge Stealth 3.0L V6 DOHC
1992–1994 Eagle Summit, Dodge Colt 2.4L 4 Cyl.
1984–1991 Dodge Colt 2.0L 4 Cyl.



1. Set engine to TDC #1 of the compression stroke. Align the timing marks on the pulleys with the marks on the engine. Refer to the appropriate service manual for timing mark locations.
2. Install the timing belt onto the engine in a counterclockwise direction starting with the crankshaft.
3. Loosen the tensioner pulley bolt, and install No. 522901 Timing Belt Wrench into the holes in the pulley.
4. Refer to the appropriate service manual to find the correct OE torque specification for the tensioner. Use a 1/4" beam-style torque wrench to turn the timing belt wrench and put tension on the timing belt. Tighten the tensioner pulley bolt.
5. Rotate the crankshaft two complete revolutions, and verify the timing marks are lined up.

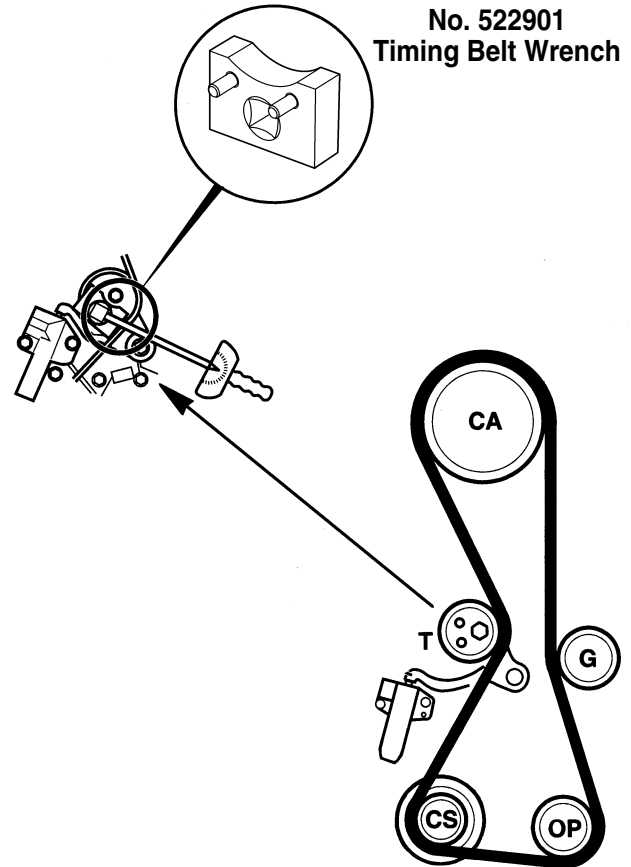

 **CAUTION:** To prevent personal injury, wear eye protection that meets ANSI Z87.1 and OSHA standards.

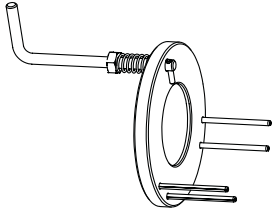

No. 522902 Secondary Timing Chain Holder

Application : 1999–newer Jeep Grand Cherokee 4.7L V8

1. Install both secondary chains onto the idler sprocket. Align the two plated links on the secondary chain to be visible through the two lower openings on the idler sprocket. Position No. 522902 Secondary Timing Chain Holder to hold the chain in place. See Figure 1.
2. Align the primary chain double-plated links with the timing mark at 12:00 on the idler sprocket. See Figure 2.
3. Align the primary chain single-plated link with the timing mark at 6:00 on the crankshaft sprocket.
4. Lubricate the idler shaft sprocket shaft and bushing, and install on the engine.

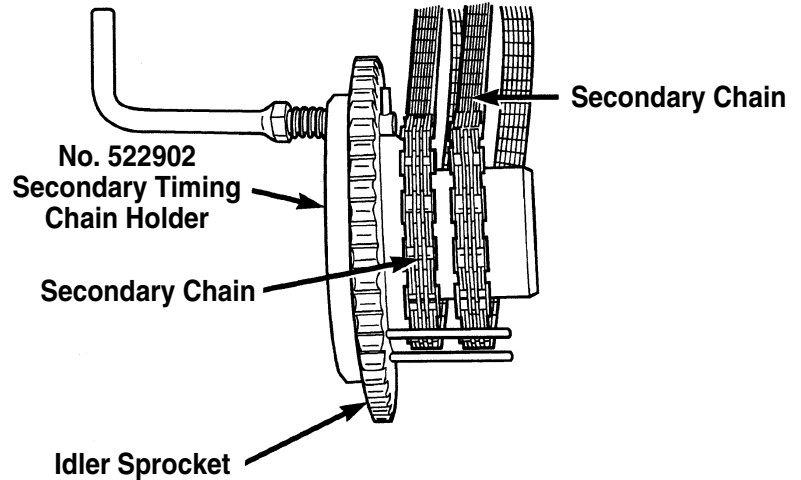

Figure 1

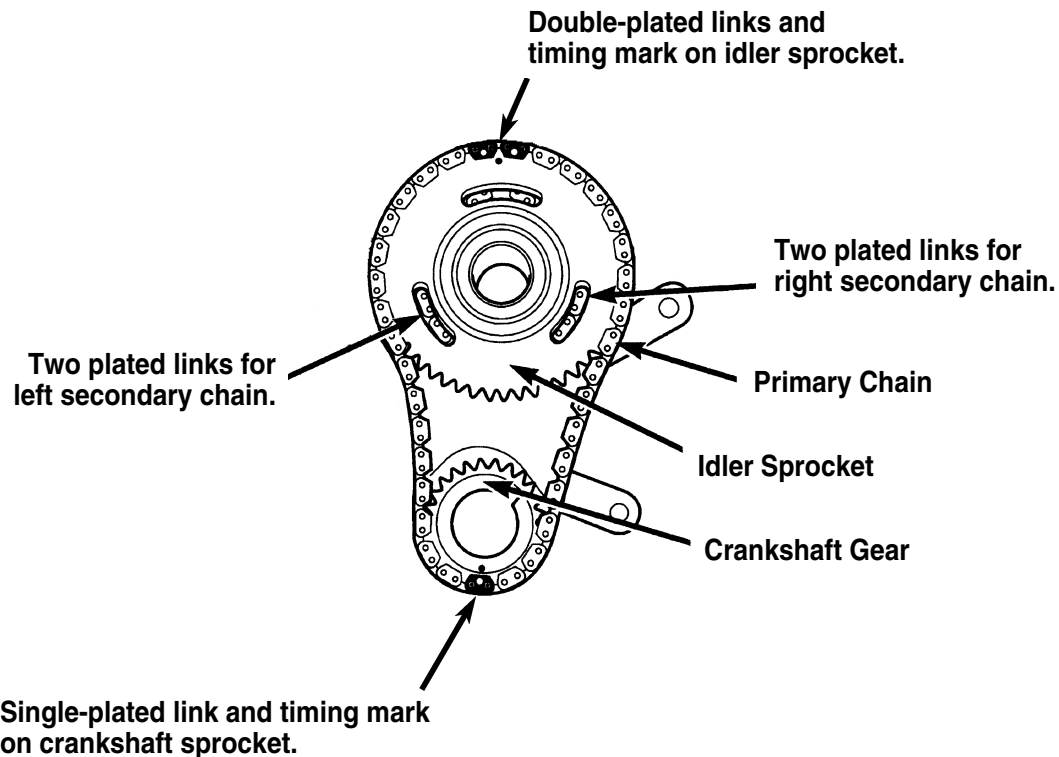



Figure 2

 **CAUTION:** To prevent personal injury, wear eye protection that meets ANSI Z87.1 and OSHA standards.