

Parts List &
Operating Instructions
for:

5077A

Transfer Tanker

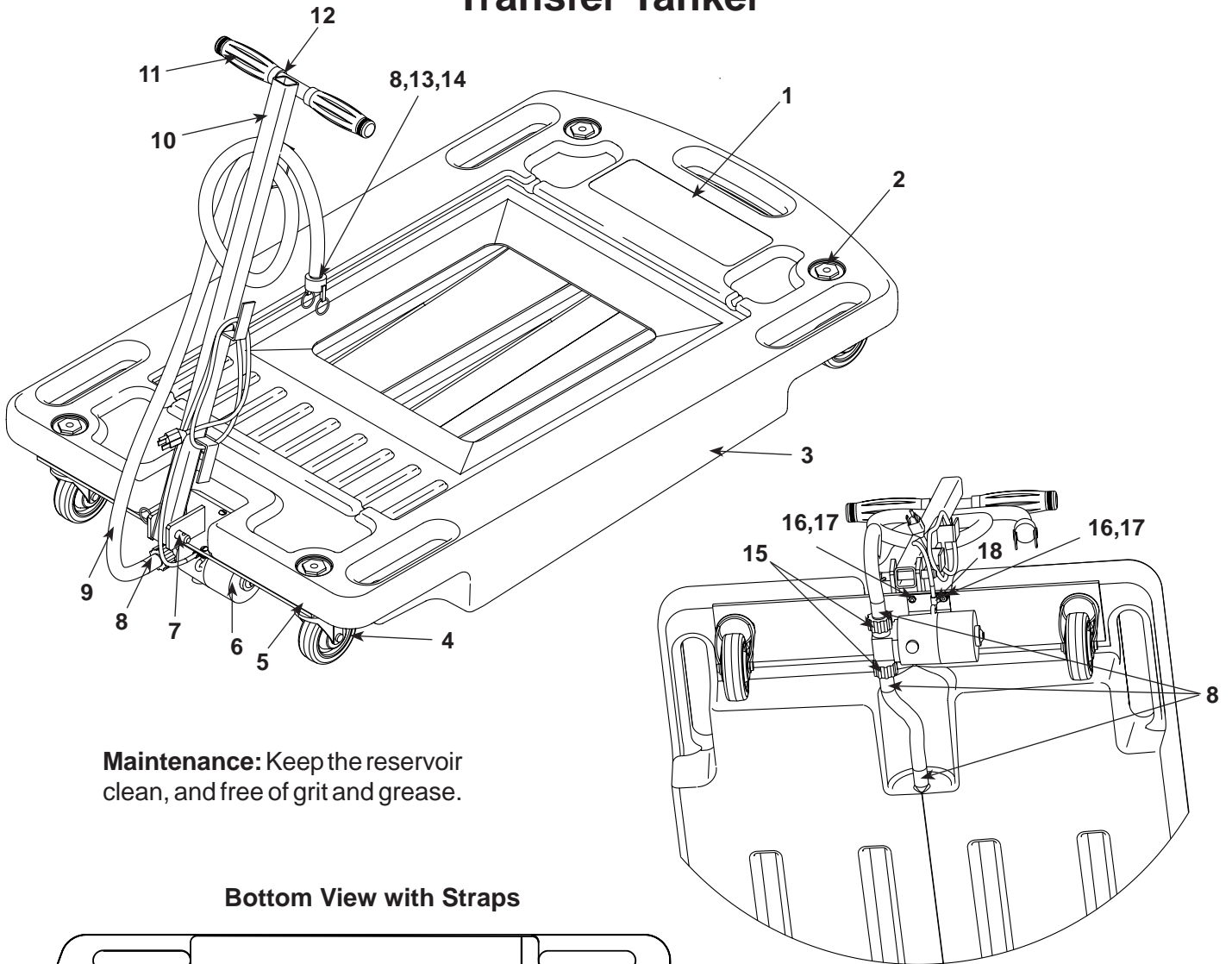

Maintenance: Keep the reservoir clean, and free of grit and grease.

Bottom View with Straps

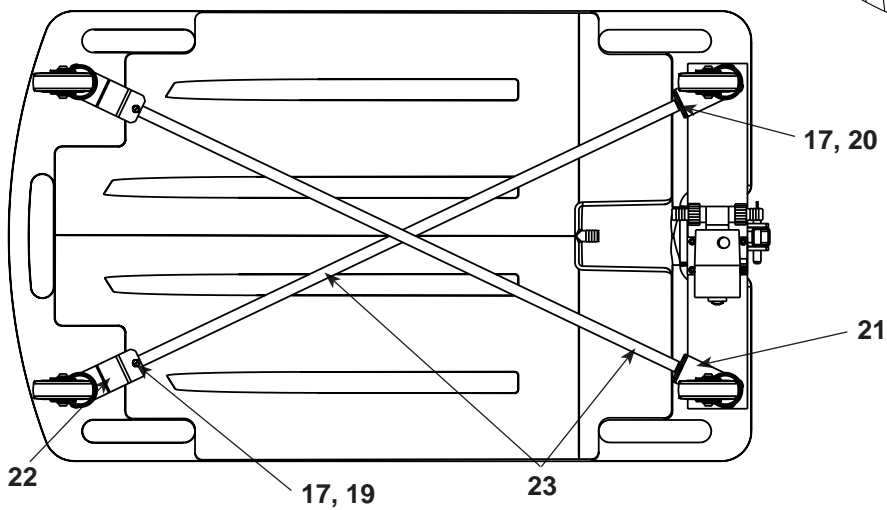

Parts List & Operating Instructions

Parts List

Item No.	Part No.	No. Req'd	Description
3	528089	1	Oil Reservoir
6	528093	1	Pump Motor with Switch *
N/A	222693	1	Filter Screen

* A repair kit is available for pump No. 528093: No. 222907 Impeller Kit

Caster Kit No. 564210

Item No.	No. Req'd.	Description
2	4	Threaded Insert
4	4	Swivel Caster (4 in.)

Handle Kit No. 564211

Item No.	No. Req'd.	Description
5	1	Handle Mount
10	1	Handle
11	2	Handle Grip

Hardware Kit No. 564212

Item No.	No. Req'd.	Description
1	1	Logo / Warning Decal
7	1	Cotterless Hitch Pin
12	1	Cap
16	4	Screw (10-24 x .625)
17	8	Hex Locknut (10-24 UNC, Steel)
18	1	Cable Clamp
N/A	4	Screw (#10 x 3/4 Long)

Hose Kit No. 564213

Item No.	No. Req'd.	Description
8	4	Hose Clamp (.68-1.25)
9	1	Tubing
13	1	Hose Fitting
14	1	Fitting Cap
15	2	Hose Fitting

Strap Kit No. 564214

Item No.	No. Req'd.	Description
19	2	Machine Screw, (10-24 x .500)
20	2	Round Head Machine Screw (10-24 UNC x 1.00)
21	2	Front Plate
22	2	Rear Plate
23	2	Strap

Safety Precautions



WARNING: To prevent personal injury and property damage,



- Read, understand, and follow all operating instructions and safety precautions before using the transfer tanker. If the operator cannot read these instructions and safety precautions, they must be read and discussed in the operator's native language.



- Wear eye protection that meets ANSI Z87.1 and OSHA standards.



- **RISK OF FIRE:** The transfer tanker has an electric motor. Do not transport flammable, volatile fluids, such as gasoline, kerosene, or diesel fuel, which could cause fire or an explosion.



- **RISK OF FIRE:** Use the transfer tanker to transport only motor oil or ethyl glycol.
- **RISK OF FIRE:** Do not use the transfer tanker in the vicinity of flammable materials, fumes, or vapors which could cause fire or an explosion.
- Do not modify the transfer tanker or use it in a manner other than its intended purpose.

CAUTION: To prevent equipment damage,

- Do not run the pump when it is dry, which could damage the pumping mechanism.
- Fluids thicker than SAE 40 motor oil (at room temperature) can put a heavy load on the motor. This may cause the thermal switch to open, shutting off the motor. If this happens, allow the motor to cool for at least 30 minutes with a fan blowing over it.

Parts List & Operating Instructions

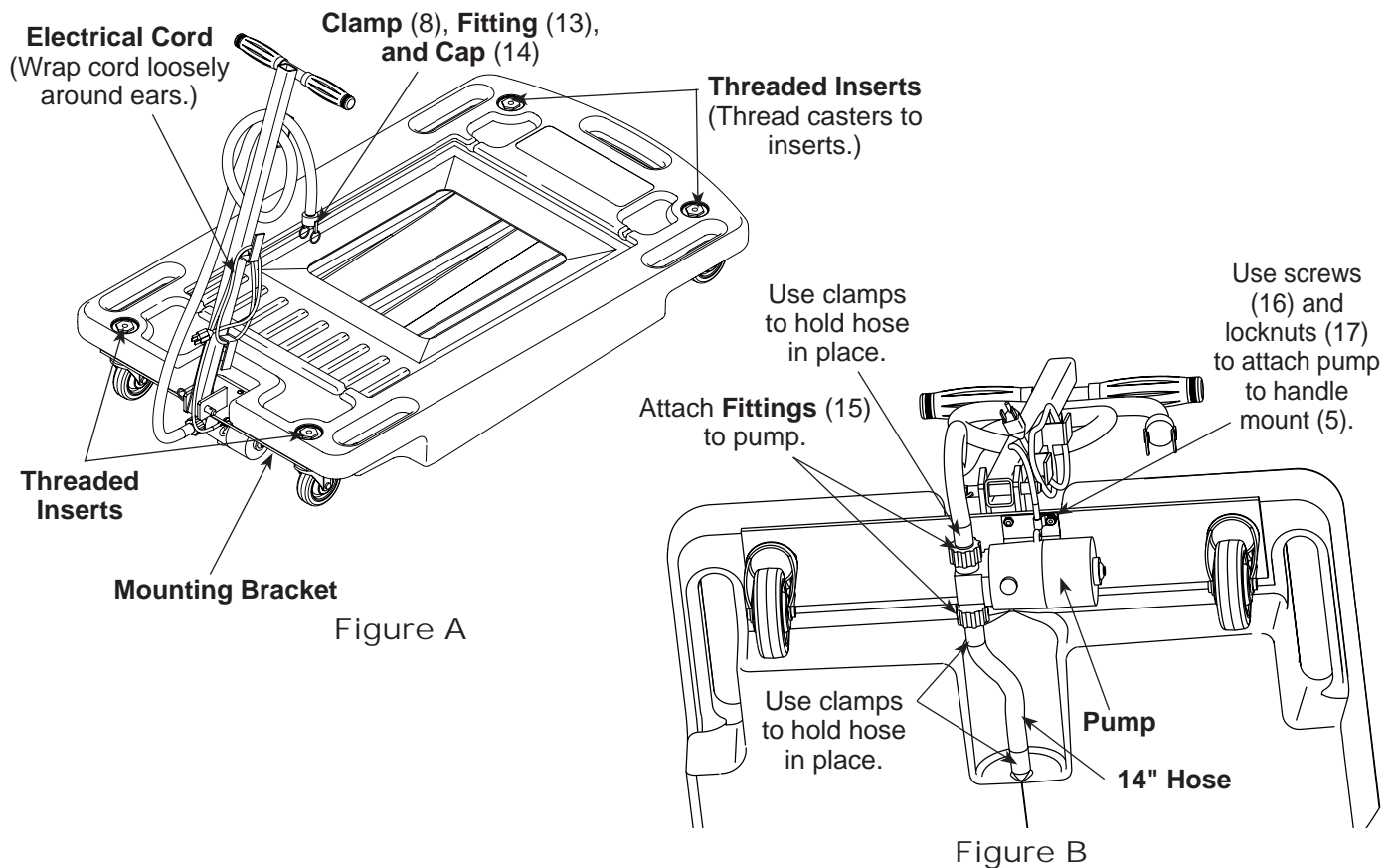

Assembly Instructions

(Refer to parts list for item numbers in brackets.)

1. Thread the fittings to the pump (see Figure B).
2. Mount the pump to the bottom of the handle mount (5) using four screws (16) and locknuts (17). *Note: The direction of the screws must point away from the reservoir.*
3. From the top of the reservoir, install the four threaded inserts (see Figure A).
4. From the bottom of the reservoir, attach the handle mount (5) using the two front plates (21) and two casters. Insert the caster studs through the large holes in the front plates and through the slots in the handle mount. Install the caster studs into the front threaded inserts (hand tighten only).
5. Attach a strap to each of the rear plates (22) using a screw (19) and a locknut (17). *Note: The direction of the screws must point away from the reservoir.*
6. Insert the caster studs through the holes in the rear plates, and then install the caster studs into the rear threaded inserts (hand tighten only).
7. Position the straps as shown in the illustration on Sheet 1 of 2. Attach the straps to the front plates using screws (20) and locknuts (17). *Note: The screws must be installed with the nut on the same side as the strap.*
8. Cut a 14" piece of hose from the tubing (9), and install the hose between the fitting on the reservoir and the pump inlet using two hose clamps (8).
9. Install cap (12) and grips (11) to the handle. Attach the handle to the handle mount using the cotterless hitch pin (7).
10. Attach the remaining hose to the outlet side of the pump with a hose clamp (8).
11. Attach the hose fitting (13) to the hose with a hose clamp (8), and install the fitting cap (14) (see Figure A). Wrap the hoses around the handle ears, leaving slack to enable handle movement without damaging the hoses.
12. Attach the screen to the reservoir by installing a self-tapping screw through a hole in each corner of the screen and into the reservoir.

Rear Caster / Plate

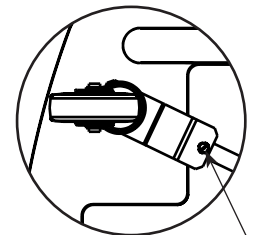

Place locknut on this side of plate.

CAUTION: Shut off the pump when the reservoir is dry; running the pump dry may cause it to burn out over time.