



4291
100 GPM Flow Block with Loading Valve
User Manual



Introduction

The OTC 4291 100 gpm Flow block is included in the OTC 4285 Hydraulic Test Kit which accurately measures flow, pressure, temperature and speed. The kit is designed for checking hydraulic pumps, motors, valves and hydrostatic transmissions. This easy-to-use diagnostic unit can pinpoint hydraulic system faults, reduce downtime and help in preventative maintenance. Main hydraulic circuits, drain leakage flows and dual pumps can be measured simply at the turn of a switch. The readout can be used in the most convenient position; for example, in the cab of a vehicle, with the flow meters installed anywhere in the circuit.

Safety Precautions



CAUTION: To prevent injury and / or property damage,



- Study, understand, and follow all safety precautions and operating instructions before using this equipment. If the operator cannot read instructions, operating instructions and safety precautions must be read and discussed in the operator's native language.
- No alteration shall be made to this product.
- Inspect the condition of the equipment before each use; do not use if damaged, altered, or in poor condition.
- Ensure load valve is fully open prior to testing.



- Wear eye protection that meets the standards of ANSI Z87.1 and OSHA.

Basic operation

Temperature

The thermistor-type temperature transducer mounted within the flow meter is in contact with the oil flow, and temperature is displayed on the left-hand side of the digital display. Temperature from the remote flow meter plugged into the side of the unit is displayed in the INT and TACH position; temperature from a remote flow meter plugged into the EXT socket on the front is displayed in the EXT position. Pressing the °C/°F button toggles the display between Centigrade and Fahrenheit; the unit selected is indicated by a cursor arrow.

Flow Block

The flow comprises an axial turbine mounted in an aluminum block. The oil flow rotates the turbine and its speed is proportional to the oil velocity. The revolutions of the turbine are measured by means of a magnetic sensing head which feeds a pulse every time a turbine blade goes by, to an electric circuit. The circuit amplifies the pulse, shapes it into square wave form and has a digital output which is directly proportional to the number of pulses per second. Flow rate is displayed in the right-hand side of the digital display when INT or EXT are selected. Pressing the **units** button switches the display to lpm, IMP gpm or US gpm and the selection is indicated by a cursor arrow. When the flow rate falls below the minimum allowable, "L" is indicated on the display. When flow rate exceeds the maximum, "H" is indicated on the display.

Loading Valve - 100 GPM Model only

All loading valves work on the same theory - a poppet is moved in and out of a flow port via a threaded shaft. The unique design of the pressure-balanced poppet ensures low handle effort throughout the flow and pressure ranges in addition to excellent tactile feedback, regardless of flow direction. In the event of overpressure, replaceable burst discs (situated within the poppet) rupture, to internally bypass the oil at low pressure.

Accessories

OTC 4292 Digital Hydraulic Readout

OTC 573295 Flow/Temp/Pressure Cable/Hose Assembly 20 ft.

OTC 573296 Flow/Temp Cable Assembly 6-1/2 ft.

Replacement Parts

OTC 573749 Test Point

OTC 573736 Burst Disc Kit

Installation guidance

1. Although the unit is bi-directional, which means it can be used in both flow directions, the preferred direction is indicated on the block. When the flow meter is used for reverse flow tests, slightly lower accuracies may be obtained depending on the oil viscosity, density and compressibility.
2. The unit can be connected to the hydraulic circuit by means of flexible hoses or rigid pipes, 8" (200 mm). The use of quick-disconnect couplings can save time. The hoses and fittings at the inlet to the unit must be of adequate size for the flow being tested. Elbows, rotary couplings etc., at the inlet and outlet ports should be avoided to ensure accurate readings.
3. Connect the cable and micro-bore hose assembly at the readout; then connect to the unit. **IMPORTANT**, after testing, disconnect at the unit first to avoid oil spillage.
4. After installing it is important to ensure that all connections are tightened and the oil can flow freely throughout the hydraulic system **BEFORE** running the machine at full speed. Check that the circuit is correctly connected and the load valve is fully open; also quick disconnect couplers **MUST** be open. **IMPORTANT**: Start the pump momentarily to ensure there is no obstruction that could cause pressure build-up.
5. Ensure that the appropriate calibration factor is entered.
6. The 4292 readout has an automatic electronic system which shuts the power off after approximately 15 minutes should you forget. To reactivate, press the ON key.

Specification

Model Number	Main ports	Top ports	Flow Range	Max. pressure
4291	1-5/16" -12UN #16 SAE ORB	7/16" -20UN #4 SAE ORB	2.5 - 100 US gpm 10 - 400 lpm	6000 psi 420 bar

Functional specification

Ambient temperature:	41 - 104 °F (5 to 40 °C)
Fluid type:	Oils, fuels, water glycol, water oil emulsions
Fluid temperature:	41 - 194 °F (5 to 90 °C) continuous use
Accuracy:	15 to 100% of range = ± 1% of indicated reading Below 15% fixed accuracy of 1% of 15% of full scale
Degree of protection*:	IP66 (EN60529) *With cable connected

Electrical specification

Output:	Frequency - 20 -2000 Hz
Impedance:	3700 ohm
Inductance:	1kHz: 1.55H

Construction material

Flow body:	Aluminum 2011 T6
Internal parts:	Aluminum, Steel, Stainless Steel
Transducer:	Body and nut -steel 212A42 electroless nickel plated Lid and housing - Aluminum 2011 T3
Seals:	FKM

Dimensions: inches (millimeters)

Model Number	A	B	C	D	E	F	G	Weight lbs. (kg)
4291	2" (49)	4" (100)	7-1/8" (182)	8-3/4" (222)	4" (102.5)	1-7/8" (47.6)	6" 150	8.1 (3.7)

Add 3/4" (20 mm) to G for full height including feet.

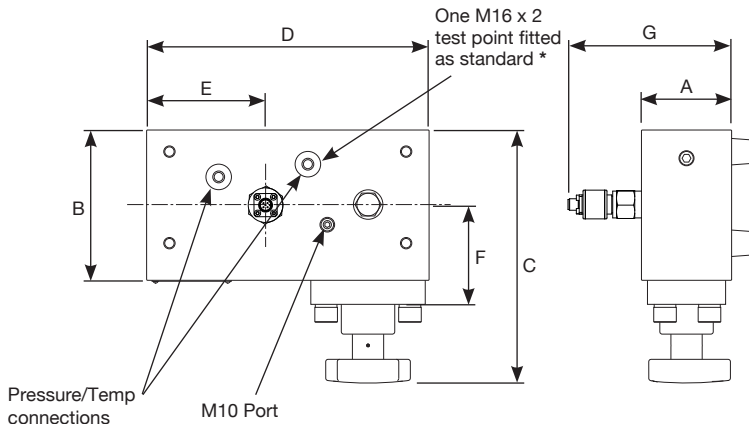

* Port connected via shuttle valve to ensure maximum pressure is measured regardless of flow direction.

Installation guidance

- All hydraulic connections should be made by suitably qualified personnel.
- Avoid sharp bends because high pressure hoses will deflect and straighten under pressure.
- A preliminary check of the hydraulic system's oil supply, pump rotation, filters, oil lines, cylinder rods, as well as looking for external leaks, should be made prior to installing the unit.
- Although the unit can be used in both flow directions, the preferred direction is indicated by the larger arrow on the panel. When used for reverse flow tests, slightly lower accuracies may be obtained depending on the oil viscosity, density and compressibility.
- The unit should be connected to the hydraulic circuit by means of flexible hoses 3 - 6 ft. (1 - 2 metres) long.
- The use of quick-disconnect couplings can save time. Make sure the hoses are long enough so the unit can be used safely on the machine.
- The hoses and fittings at the inlet must be of adequate size for the flow being tested. Elbows, rotary couplings etc., at the inlet and outlet ports should be avoided to ensure accurate readings.
- The use of the flexible hoses will help to isolate the unit from vibration which often exists.
- The internal burst discs are to protect the unit, not the hydraulic installation. Always ensure the appropriate relief devices are fitted to protect the installation.

All hydraulic connections should be made by suitably qualified personnel. Inlet and outlet connections should always have a similar bore size to that of the flow meter to prevent venturi or constriction effects.

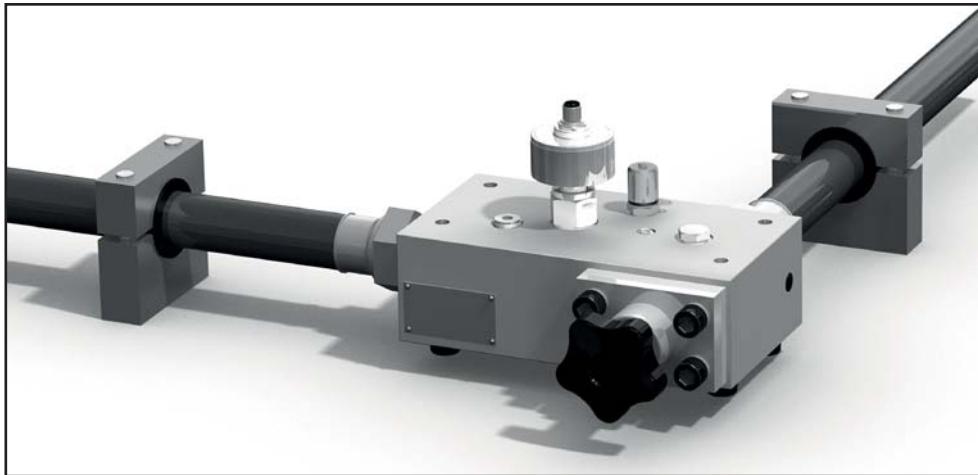

Flow meter shown in typical mounting.

Connection Details

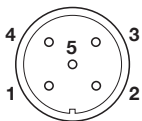

Pins

- 1 = Freq +ve
- 2 = Freq -ve
- 3 = Temp
- 4 = Temp
- 5 = N/C

N.B. N/C = Do not connect

Technical information

All flow meters are calibrated at 21 cSt as standard. Special calibration is available over a custom flow range or at a different viscosity. Please contact OTC Technical Services to discuss your application.

Pressure Drop Chart

Hydraulic Oil Viscosity 21 Centistokes (fully open load valve)

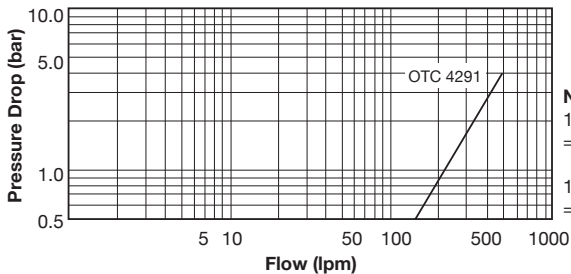

Note

1 UK gallon
= 4.546 litres

1 US gallon
= 3.785 litres

Maintenance and Service

Replacement of burst discs (No. 573736)

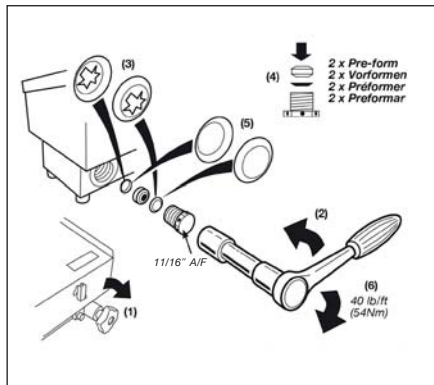

- Disconnect the unit from the hydraulic circuit
- Locate the new discs - the unit is shipped with spare discs located in the block
- Screw the load valve fully shut - (clockwise)
- Unscrew the disc holder from the valve
- Remove the disc spacer and ruptured discs from the valve and disc holder
- Carefully shape the two new discs by pressing them by hand between the disc holder and spacer
- Place the first disc inside the valve
- Replace the spacer
- Place the second disc on top of the spacer
- Screw in the disc holder, tighten to 40 lb/ft (54 Nm)
- Unscrew the load valve fully
- Re-connect the unit if required

Note: Diagram shows OTC 4278. OTC 4291 has same procedure.

Calibration

Flow measurement equipment, such as flow meters and flow blocks, should be calibrated annually or after every 2,000 hours of use. Calibrate the equipment more frequently if it is used or stored in environments where the equipment is exposed to dust or vibrations.

Fluid viscosity

The performance of a turbine flow meter can be affected by the viscosity of the fluid measured. Our turbine flow meters are calibrated at between 18 and 26 cSt as standard (a mean viscosity of 21 cSt), which is the typical kinematic viscosity for a hydraulic fluid operating at 50 °C. The kinematic viscosity of all hydraulic fluids is related to the fluid temperature, and the table below shows the effect of temperature on the kinematic viscosity of a range of typical grades of hydraulic oil.

The shaded area of the table shows the range of viscosities that can be measured by a flow meter with standard calibration with minimal effect on the accuracy (less than $\pm 1\%$ FS).

Flow meters can be specially calibrated at a different viscosity to the standard, or we can advise on the expected error when the flow meter is used at other viscosities.

Table showing kinematic viscosity (cSt) of different mineral oils at specific temperatures

Temp °C	Fluid type					
	ISO15	ISO22	ISO32	ISO37	ISO46	ISO68
0	85.9	165.6	309.3	449.9	527.6	894.3
10	49.0	87.0	150.8	204.7	244.9	393.3
20	30.4	50.5	82.2	105.5	127.9	196.1
30	20.1	31.6	48.8	59.8	73.1	107.7
40	14.0	21.0	31.0	36.6	44.9	63.9
50	10.2	14.7	20.8	23.9	29.4	40.5
60	7.7	10.7	14.7	16.5	20.2	27.2
70	6.0	8.1	10.9	12.0	14.6	19.2
80	4.8	6.4	8.4	9.1	11.1	14.3
90	4.0	5.2	6.6	7.2	8.7	11.1
100	3.3	4.3	5.5	6.0	7.1	8.9

ISO 15, 22, 32, 46 and 68 based on typical figures for the Esso Nuto range of HM oils. ISO 37 based on Shell Tellus HM oil.