



DIESEL FUEL INJECTION NOZZLE TESTER

Read and carefully follow these instructions. Most problems with new equipment are caused by incorrect operation or installation. Carefully inspect the tester upon arrival. The carrier, not the manufacturer, is responsible for any damage resulting from shipment.

SAFETY PRECAUTIONS



WARNING: To help prevent personal injury,

- Wear approved safety glasses at all times.
- Volatile liquids can be extremely flammable when vaporized. Avoid any conditions (sparks, open flames, lit cigarettes, etc.) that could ignite the fluid used during the test procedure.
- Always use the tester in a well ventilated area.
- When a nozzle is being tested or is in operation, keep clear of the spraying nozzle. The liquid spray leaves the nozzle tip with enough force to penetrate the skin and could cause serious personal injury. Enclose the nozzle tip in a transparent receptacle to contain the spray.

SET-UP

1. Remove the filler plug. Fill the reservoir to full capacity with clear diesel fuel or an SAE-approved calibration oil such as OTC #208629.
2. Remove the plastic plug from the tester outlet port. Attach the connector tube to the 45° outlet elbow on the nozzle tester. See Figure 1. Select adapters that are correct for the application and attach them between the connector tube and injection nozzle.

NOTE: The connector tube, adapters, and hoses are not included with the basic tester. See your OTC distributor for information about adapter sets (OTC #4201, #4202, and #4203).

3. Refer to the equipment manufacturer's service specifications and procedures for all testing information.

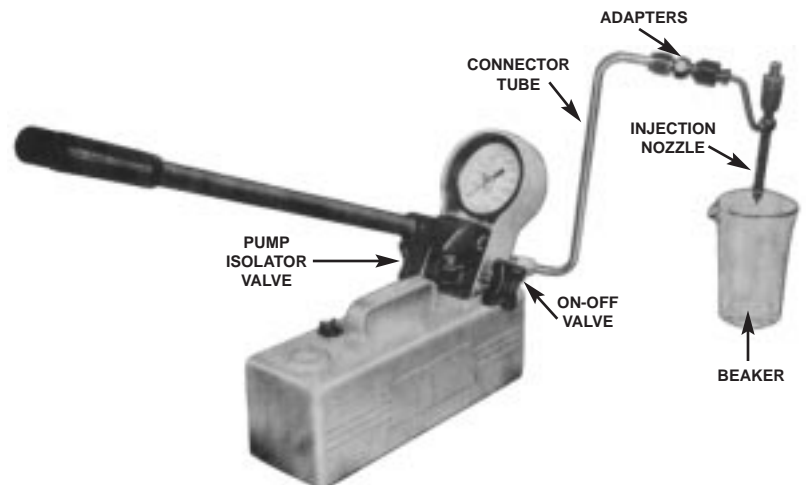
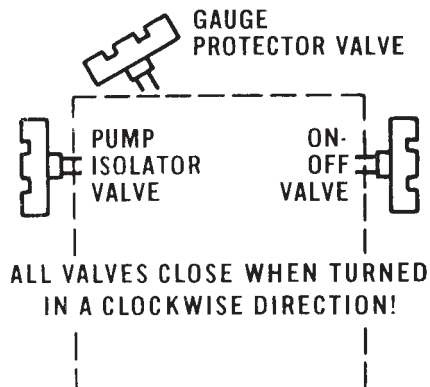

FIGURE 1

OPERATION

VALVE IDENTIFICATION DIAGRAM



HYDRAULIC SCHEMATIC

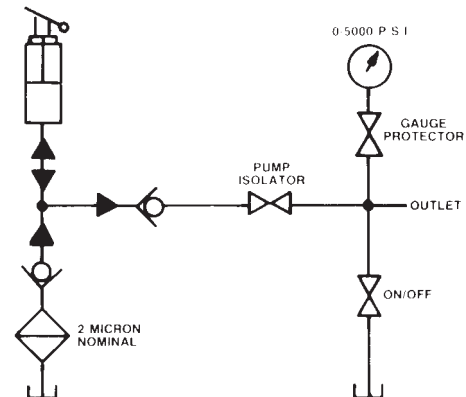

Purging Air from the Connector Hardware and Nozzle

1. Assemble the hardware, and place a container under the outlet. Flush the hardware with fluid from the pump and remove any internal contamination.
2. Attach the injection nozzle. Tighten adapters. Close the ON/OFF valve and the gauge protector valve.
3. Open the pump isolator valve about 1/4 turn from the closed position. Rapidly pump the handle to clear the connector line and injection nozzle of air.

Pop-Off Pressure Test

1. Open the pump isolator valve and the gauge protector valve about 1/4 turn from the closed position. Close the ON/OFF valve.
2. Place the maximum reading indicator (the red needle) well below the specified "cracking" or pop-off pressure. SLOWLY pump the handle to build system pressure to the point where the nozzle pops. The pop-off pressure will be shown by where the indicator stops. Refer to the manufacturer's specifications for the correct nozzle opening pressure the stroke rate of the nozzle tester.

IMPORTANT: Operating the pump handle too fast results in the wrong cracking pressure as well as excessive wear on the gauge.

Spray Pattern Test

1. Repeat the pop-off pressure test.
2. Compare the quality of the resulting spray pattern with the manufacturer's specifications.

Chatter Test

1. Purge air from nozzle according to the instructions above.
2. Compare the audible chatter of the nozzle to the manufacturer's recommendations (if applicable to the nozzle being tested).

Leakage Test

1. Open the pump isolator valve and the gauge protector valve about 1/4 turn from the closed position. Close the ON/OFF valve.
2. Pump the handle to build pressure to about 100 PSI below the recommended pop-off pressure.
3. Close the pump isolator valve. Check for leakage at the nozzle and a pressure drop on the gauge. Refer to the manufacturer's specifications for an acceptable leakage rate.

PREVENTIVE MAINTENANCE

1. Change the tester's filter element every 12 months to keep foreign materials from passing through the filter element into the nozzle assemblies.
2. Discard the calibration oil when it becomes contaminated or discolored, or when the length of time required for the foam to settle is more than 60 seconds.

Parts List for:

4200

MODEL B FUEL INJECTION NOZZLE TESTER

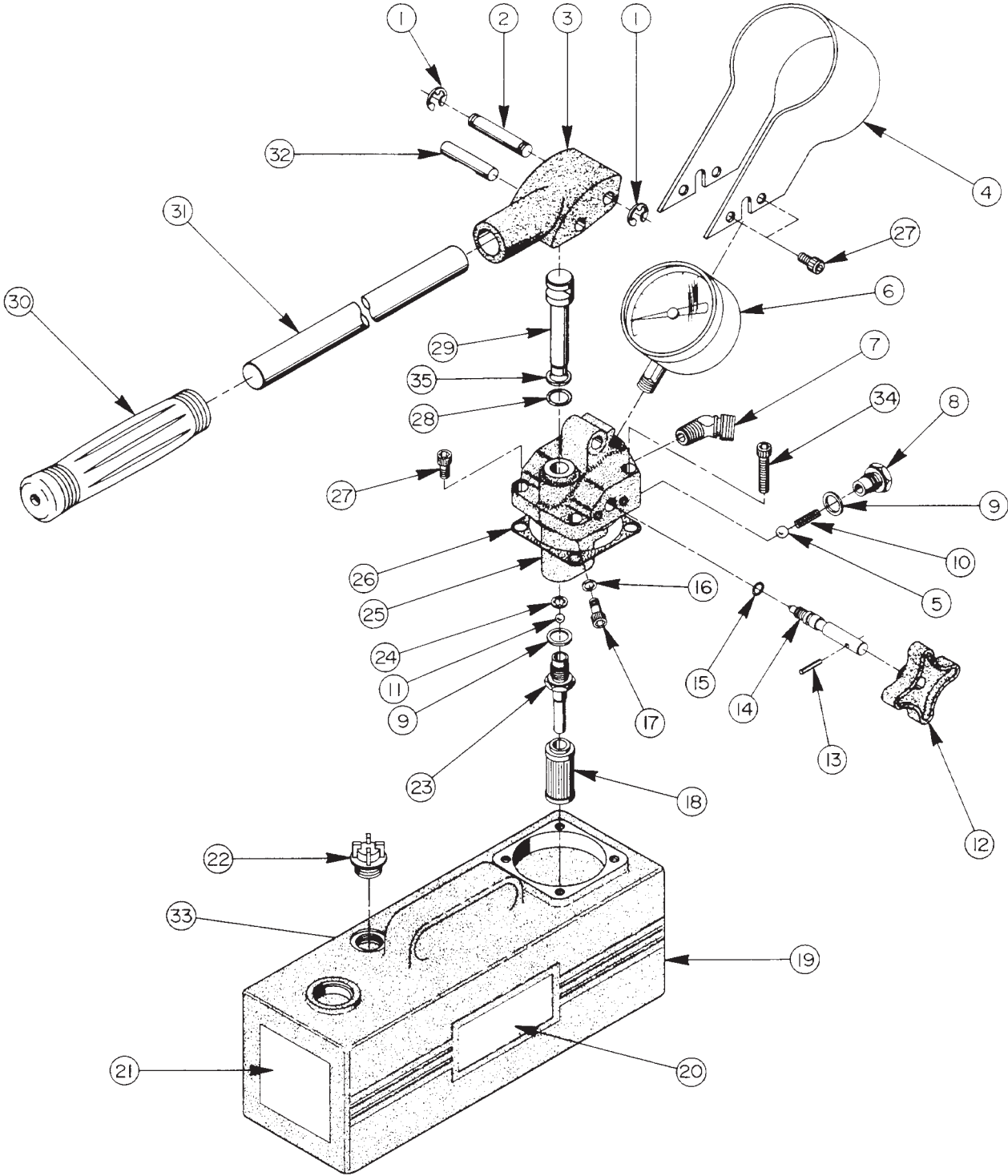

| Item No. | Part No. | No. Req'd | Description |
|----------|----------|-----------|--|
| 1 | 11032 | 2 | Retaining Ring (For 3/8" shaft) |
| 2 | 23088 | 1 | Clevis Pin |
| 3 | 32201BK2 | 1 | Lever |
| 4 | 45987 | 1 | Gauge Guard |
| 5 | *10377 | 1 | Steel Ball (5/16 Dia.) |
| 6 | 11565 | 1 | Pressure Gauge |
| 7 | 23485 | 1 | Elbow |
| 8 | 21704 | 1 | Valve Screw (Torque to 35/40 ft. lbs.) |
| 9 | *10901 | 2 | Brass Washer (11/16 X .513 X 1/16) |
| 10 | *11451 | 1 | Compression Spring (1/4 O.D. X 5/8 Lg.) |
| 11 | *10375 | 1 | Steel Ball (1/4 Dia.) |
| 12 | 23272 | 3 | Knob |
| 13 | 10895 | 3 | Roll Pin (1/8 Dia. X 3/4 Lg.) |
| 14 | 23271 | 3 | Regulator valve Stem |
| 15 | *10266 | 3 | O-ring (3/8 x 1/4 X 1/16) |
| 16 | *10442 | 1 | Copper Washer (3/8 X 1/4 X 1/32) |
| 17 | 10002 | 1 | Soc. Hd. Cap Screw (1/4-20 X 3/8 Lg.; Torque to 110/120 in. lbs.) |
| 18 | 17169 | 1 | Filter Element (2 Micron) |
| 19 | 40559BL2 | 1 | Reservoir |
| 20 | 215394 | 1 | Trade Name Decal |
| 21 | 12049 | 1 | Decal (Valve Identification) |
| 22 | 20937 | 1 | Filler Plug |
| 23 | 24156 | 1 | Filter Connector (Torque to 45/50 ft. lbs.) |
| 24 | *11563 | 1 | Retaining Ring (For 7/32 shaft) |
| 25 | 61951 | 1 | Pump Body |
| 26 | *23276 | 1 | Pump Body Gasket |
| 27 | 10807 | 6 | Soc. Hd. Cap Screw (1/4-20 X 1/2 Lg.) |
| 28 | *11564 | 1 | O-ring (11/16 X 1/2 X 3/32) |
| 29 | 23117 | 1 | Piston |
| 30 | 12325 | 1 | Flex Grip |
| 31 | 23120 | 1 | Handle |
| 32 | 21645 | 1 | Wrist Pin |
| 33 | 306414 | 1 | Warning Decal |
| 34 | 10020 | 2 | Soc. Hd. Cap Screw (1/4-20 X 1-1/4 Lg.) |
| 35 | *213987 | 1 | Backup Washer (11/16 X 1/2 X 3/64) |

Part numbers marked with an asterisk (*) are contained in Repair Kit No. 300499.