

## IAC Signal Tester

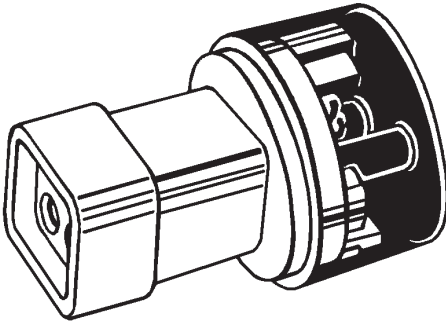

**The 3052S has a square 4-pin connector. It fits 1982 and newer GM vehicles with TBI and PFI fuel systems.**

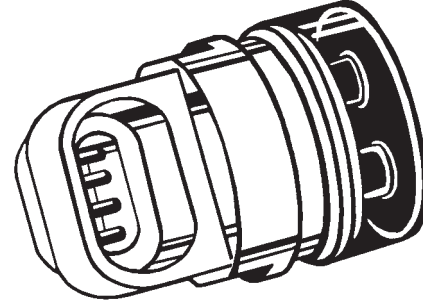

**The 3053S has a flat 4-pin connector. It fits 1987 and newer GM vehicles with Model 700 TBI and PFI fuel systems.**

The IAC Signal Tester is used to check the Idle Air Control (IAC) circuit. There are two different types of signal testers. Use the signal tester shaped like the connector on your vehicle wiring harness.

### Using The IAC Signal Tester With An Idle Air Control/Idle Speed Control Tester (3320)

1. Disconnect the vehicle wiring harness from the IAC on the throttle body.
2. Connect the Idle Air Control/Idle Speed Control tester to the IAC motor on the throttle body.
3. Connect the signal tester to the vehicle wiring harness.

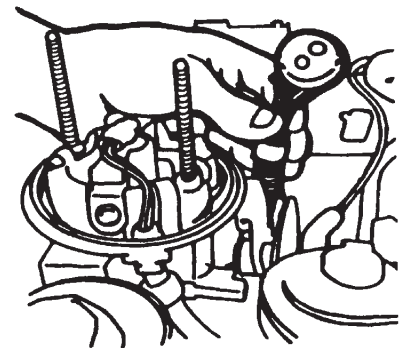

### Checking The IAC Circuit

1. Start the vehicle. Extend and contract the IAC valve using the controls on the Idle Air Control/Idle Speed Control tester. Each lamp on the signal tester should flash red and green while the IAC is cycled. The sequence of the colors is not important.
2. If either light does not flash, check the circuit between the vehicle ECM and the harness connector for broken wires and poor connections.

If both lights flash and the engine speed does not change when the IAC/ISC tester is operated, the IAC valve may be defective.

If the circuit between the ECM and the IAC signal testers is good, the ECM may be defective.

### Using The IAC Signal Tester Alone

1. Disconnect the vehicle wiring harness from the IAC on the throttle body.
2. Connect the signal tester to the vehicle wiring harness.

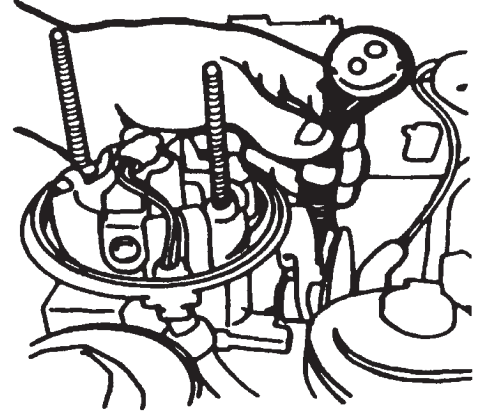

### Checking The IAC Circuit.

If you are using only the IAC signal tester, you must do two things: check the circuit when there is a demand for a larger amount of air through the IAC valve, and check the circuit when there is a demand for a smaller amount of air through the IAC valve. This procedure tells how:

1. Create a demand for large amounts of air to be passed through the IAC valve. To do this, create a load on the engine at idle either by turning the Air Conditioning on, or by turning the front wheel completely to the left or right until it locks.
2. The increase in load will cause the engine RPM to decrease. Then the ECM should begin sending signals to the IAC to change the position of the pintle to allow more air to pass through it.
3. If the ECM is sending the signal to the IAC as described above, both LEDs on the signal tester should be lit. Color is not important.
4. If either light is not lit, inspect the circuit between the ECM and the IAC harness connector for broken wires or poor connections. If all wires and connections are good, the ECM may be defective.
5. Create a demand for less air to pass through the IAC valve by creating a vacuum leak to the intake manifold.
6. When a leak is large enough, the RPM should begin to increase. The ECM should begin sending signals to the IAC to change the position of the pintle to reduce the amount of air passing through it.
7. If the ECM is sending the signal to the IAC as described above, both LEDs on the signal tester should be lit. Color is not important.
8. If both lights flash and the IAC does not respond to the signals from the ECM (while hooked to the vehicle wiring harness), the IAC valve may be defective. If either light is not lit, inspect the circuit between the ECM and the IAC harness connector for broken wires or poor connections. If all wires and connections are good, the ECM may be defective.