

## Mounting Plate Application Charts

(used with OTC #1750A Engine Repair Stand)

Mounting Plate No.	Used On
206386	4-152, 4-196, V-304, V-345, V-392, MV-404, MV-446, DV-550, D 9.0L, 6.9L, DT-360, DT-466

**WARNING:** To prevent personal injury,



- Wear eye protection that meets ANSI Z87.1 and OSHA standards.

- Tighten all mounting screws and bolts before starting work on the engine.



- Use only SAE Grade 8 cap screws to mount the plate to the engine and to the engine support.

### Installation Instructions

1. Bolt the mounting plate to the engine as shown in one of the following application charts.
2. Find the engine's center of balance (or greatest concentration of weight). *Note: This is usually about two inches above the center of the crankshaft.* See Figure 1.
3. Attach side plates to the engine mounting adapter plate, but leave the cap screws and nuts loose.
4. Align the engine (with side plates attached to the adapter plate) with the universal mounting adapter plate. Raise or lower the engine until its center of balance is in-line with the rotating shaft of the engine stand.
5. Align the closest tapped holes in the universal mounting adapter plate with the holes in the side plates. Securely tighten the side plates to the engine mounting plate and to the universal mounting adapter plate on the engine stand.

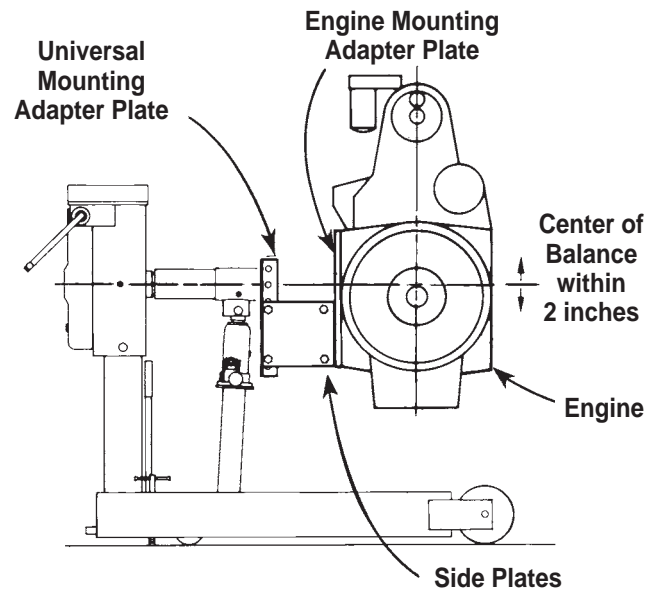

Figure 1

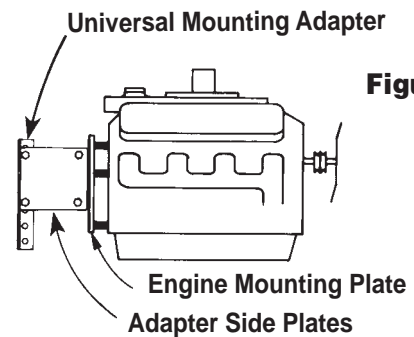
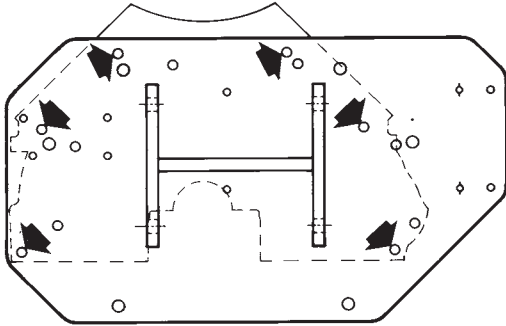

Figure 2

Fasteners	Description	Qty.	Part No.
Cap Screws	3/8-16 UNC x 1 in. lg.	8	19812
	1/2-13 UNC x 4 in. lg.	6	16481
	9/16-12 UNC x 4 in. lg.	6	206387
Washers	3/8 in. Bolt Size	8	10231
	1/2 in. Bolt Size	6	10586
	9/16 in. Bolt Size	6	10234
Spacers	1-1/8 in. O.D. x 37/64 I.D. x 2-21/32 in. lg.	6	206388

# Application Charts & Installation Instructions

## MODELS 4-152, 4-196, V-304, V-345, & V-392 REAR OF BLOCK



- ▶ (6) 1/2-13 UNC x 4 in. lg. Cap Screw, Grade 8
- (6) 1/2 in. Washer
- (6) 1-1/8 in. O.D. Spacer x 2-21/32 in. lg.

## "D" SERIES MODELS DV-550 & D 9.0L REAR OF BLOCK

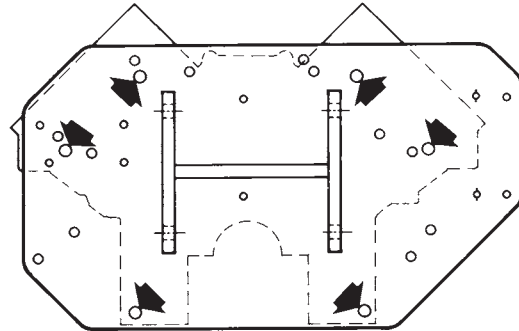

- ▶ (6) 9/16-12 UNC x 4 in. lg. Cap Screw, Grade 8
- (6) 9/16 in. Washer
- (6) 1-1/8 in. Spacer x 2-21/32 in. lg.

## MODELS MV-404 & MV-446 REAR OF BLOCK

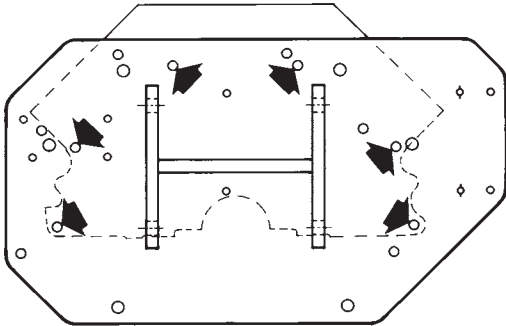

- ▶ (6) 1/2-13 UNC x 4 in. lg. Cap Screw, Grade 8
- (6) 1/2 in. Washer
- (6) 1-1/8 in. Spacer x 2-21/32 in. lg.

## MODEL DT 466 RIGHT SIDE OF BLOCK

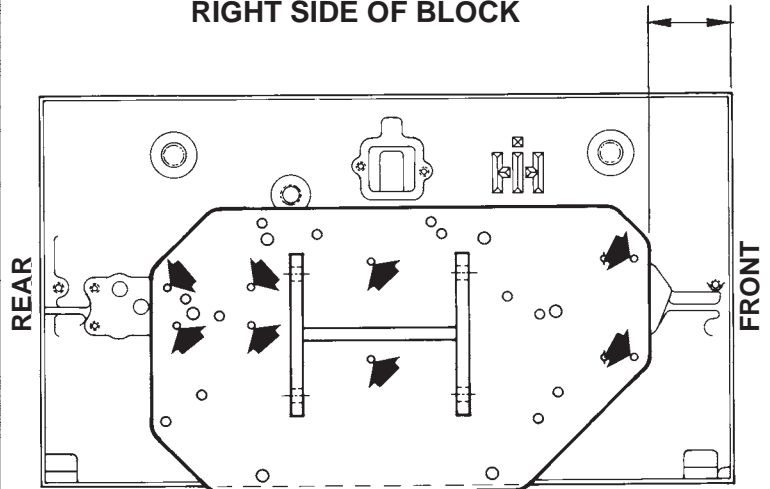

- ▶ (8) 3/8-16 UNC x 1 in. lg. Cap Screw, Grade 8
- (8) 3/8 in. Washer.

## 6.9L & 7.3L (FORD) REAR OF BLOCK

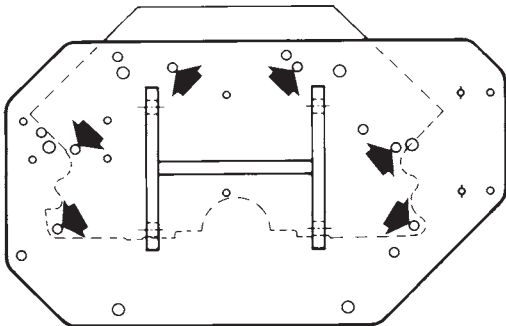

- ▶ (6) 1/2-13 UNC x 4 in. lg. Cap Screw, Grade 8
- (6) 1/2 in. Washer
- (6) 1 1/8 in. O.D. Spacer x 2-21/32 in. lg.

## MODEL DT 360 RIGHT SIDE OF BLOCK

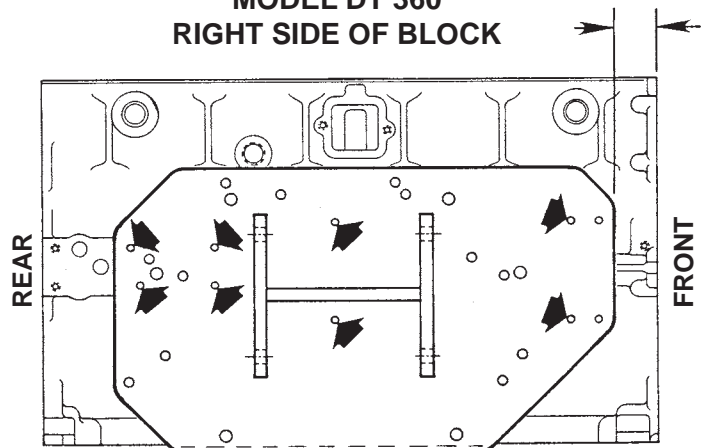

- ▶ (8) 3/8-16 UNC x 1 in. lg. Cap Screw, Grade 8
- (8) 3/8 in. Washer.