

## Vehicle Lift System

Max. Capacity: 10 Tons (Pair) at 150 PSI

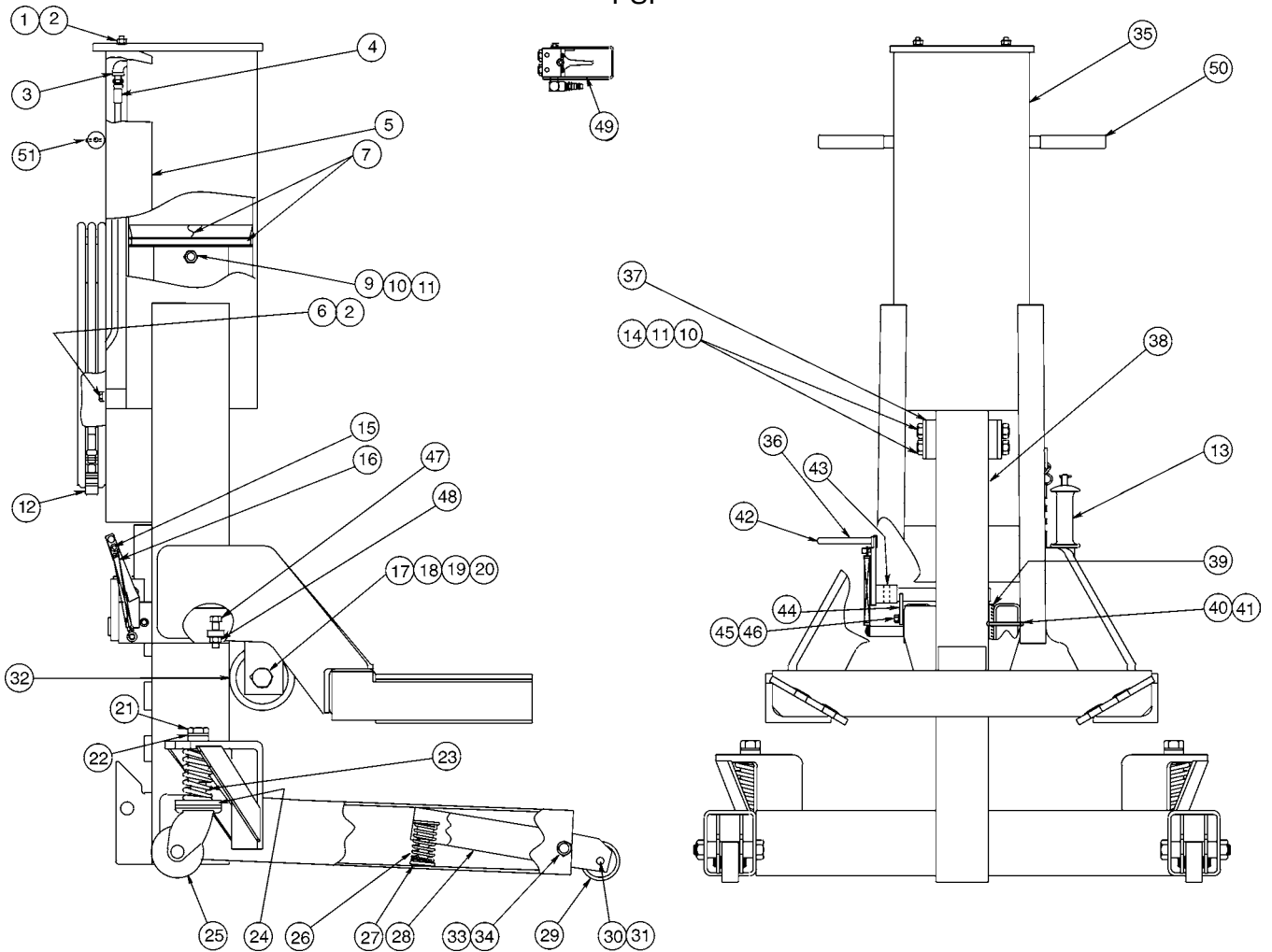

### Specifications

Max. capacity, each lift . . . . . 10,000 lbs.  
 Max. capacity, system . . . . . 20,000 lbs.  
 Max. air pressure . . . . . 150 psi  
 Min. wheel dia. . . . . 19 in.  
 Max. tire to fender clearance . . . . . 8 in.  
 Weight, each lift . . . . . 513 lbs.  
 Weight, system . . . . . 1,080 lbs.

Width . . . . . 41-9/16 in.  
 Depth . . . . . 39-1/2 in.  
 Height, lowered . . . . . 53-1/4 in.  
 Height, raised . . . . . 77-1/4 in.

Item No.	Part No.	No. Req'd	Description
1	—	2	Hex Nut (3/8-16 UNC, plated)
2	—	3	Split Lock Washer (3/8", not plated)
3	—	1	90° Street Elbow (1/4")
4	222899	1	Hose Assembly, single-wire reinforced
5	—	1	Back Cover
6	—	1	Hex Hd. Cap Screw (3/8-16 UNC x 1" lg., plated, Gr. 5)
7	515461	1	Wiper Ring, Piston & Cup Subassembly
9	—	1	Hex Hd. Cap Screw (5/8-11 UNC x 5" lg., plated)
10	—	3	Split Lock Washer (5/8", not plated)
11	—	3	Hex Nut (5/8-11 UNC, plated)
12	—	1	Quick Disconnect
13	—	1	Pin & Chain Subassembly
14	—	2	Cap Screw (5/8-11 UNC x 6-5/8" lg., not plated)
15	—	2	Palnut (1/4", washer cap, plated)
16	—	2	Extension Spring (.437 x 5" lg.)
17	—	1	Hex Hd. Bolt (1-8 UNC x 5-1/2" lg., not plated)
18	—	1	Hex Jam Nut (1-8 UNC, plated)
19	—	1	Cylindrical Bearing (1.500 OD x 1.030 ID)
20	—	2	Flanged Plain Bearing (1-1/2" nominal ID x 1.625 OD x 1-1/2" lg.)
21	—	2	Hex Hd. Cap Screw (3/4-10 UNC x 1-1/2" lg., plated, Gr. 5)
22	—	2	Washer (1-1/2" OD x 49/64" ID x 1/16" thick)
23	545171	2	Compression Spring (2-1/4" OD x 5" lg.)
24	545172	2	Caster Extension
25	222903	2	Caster (4" dia.)
26	—	2	Compression Spring (1-3/4" OD)
27	—	2	Spring Guide Pin
28	—	2	Caster Pivot Arm
29	*	2	Metallic Wheel (3" dia.)
30	*	2	Axle
31	*	4	External Retaining Ring (5/8" dia.)
32	—	1	Wheel & Grease Fitting Subassembly
33	—	2	Capscrew (3/4-10 UNC x 4-3/4" lg., plated, Gr. 5)
34	—	2	Self-Locking Hex Nut (3/4-10 UNC, plated)
35	—	1	Top Weldment
36	—	2	Downstop Release Handle
37	—	2	Stop Block
38	—	1	Base Weldment
39	547853	2	Phenolic Wear Pad
40	—	4	Rivet (1/4" dia. x 2-5/8" lg., plated)
41	—	4	Palnut (1/4", zinc plated)
42	—	2	Grip (.437 ID x 1-1/2" lg.)
43	—	2	Roll Pin (1/4" dia. x 1-3/8" lg.)
44	—	2	Pin Support Bracket
45	—	2	Hex Hd. Cap Screw (5/16-18 UNC x 1/2" lg., plated, Gr. 5)
46	—	2	Split Lock Washer (5/16" dia., not plated)
47	—	1	Hex Hd. Cap Screw (1/2-13 UNC x 2-1/4" lg., plated, Gr. 5, full length thread)
48	—	1	Hex Nut (1/2-13 UNC, plated)
49	222904	1	Dual 3-way Valve
50	✓	2	Handle Subassembly
51	✓	4	Cap Screw (1/4-20 UNC x 1-1/2" lg.)

\* Included in Wheel Kit No. 525181.  
 ✓ Included in Handle Kit No. 525182.

Indicates  
changes in  
new revision.

**Air Control Unit**

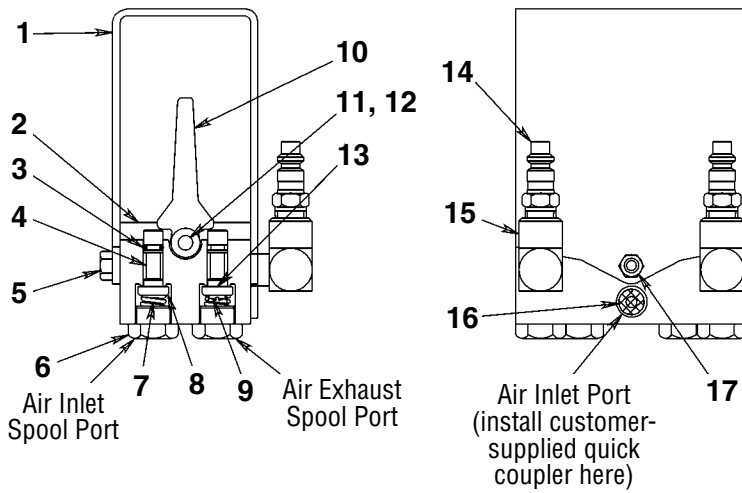

Item No.	Part No.	No. Req'd	Description
1	—	1	Valve Bracket
2	*	1	Valve Body
3	✓	2	O-ring
4	*	4	Spool
5	—	1	Hex Hd. Cap Screw (5/16-18)
6	*	4	Plug
7	✓	4	Spring
8	✓	4	Cup
9	*	4	Brass Screw (6-32)
10	*	2	Lever
11	*	2	Nut (1/4" palnut)
12	*	1	Bar Round (1/4" dia. x 3-15/16" lg.)
13	✓	4	Seal (15/32" x 3/16" x 1/8")
14	—	2	Coupler Plug
15	—	2	90° Adapter
16	✓	1	Screen
17	—	1	Hex Nut (5/16-18)

✓ included in Repair Kit No. 222906  
 \* included in Air Valve Assembly No. 222905

**Decal Placement**

All the decals shown here are included in Decal Kit No. 222901. It is the lift owner's responsibility to ensure the decals are readable, and that every user has read (or in the case of illiterate or non-English speaking users, "has been read to") and understands all warnings, safety precautions, and instructions.

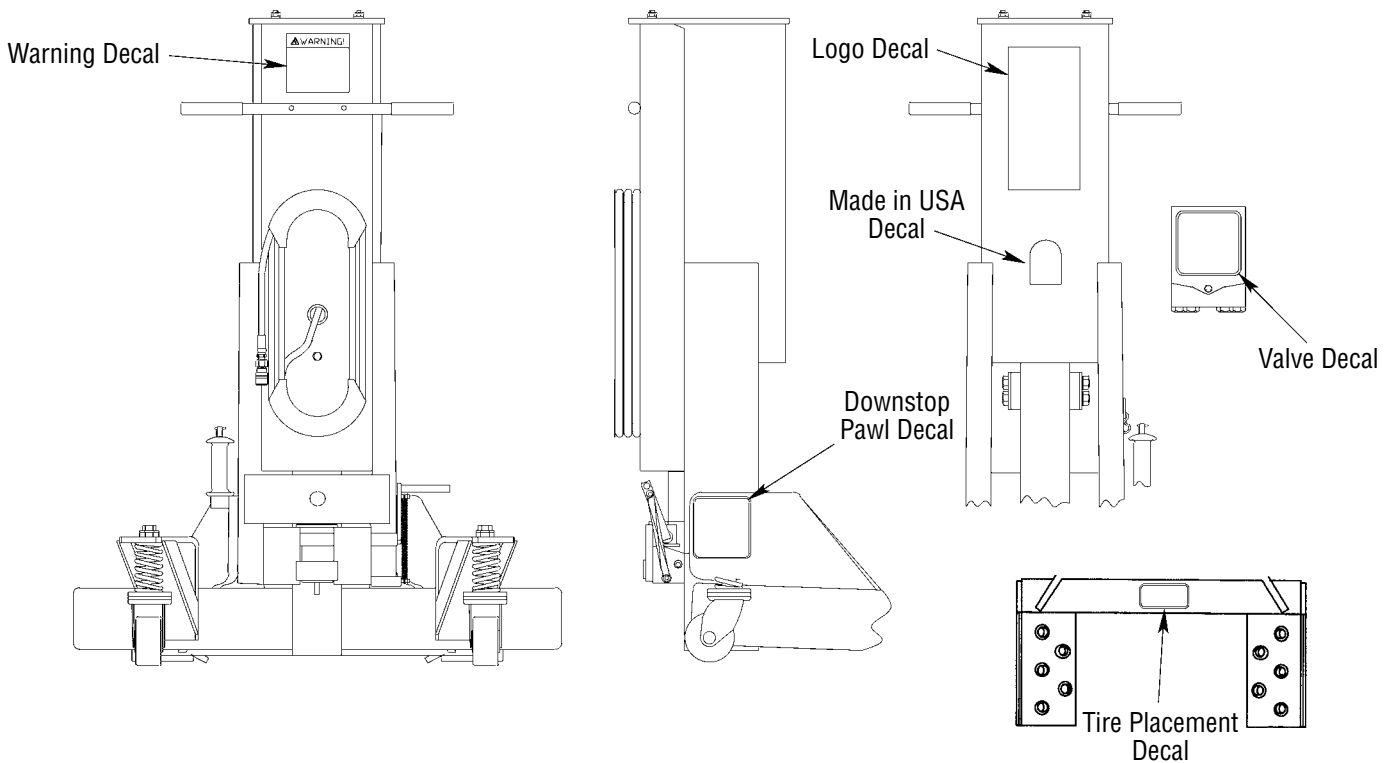

## Safety Precautions

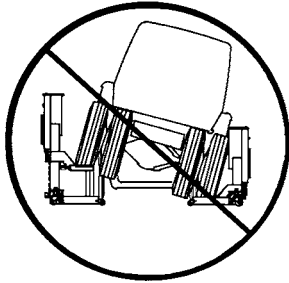

Do not raise / lower one side of a vehicle.

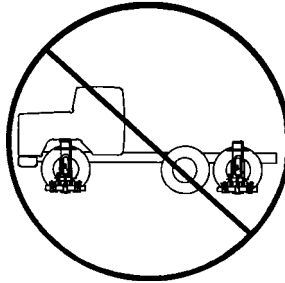

Do not raise one side of a vehicle.

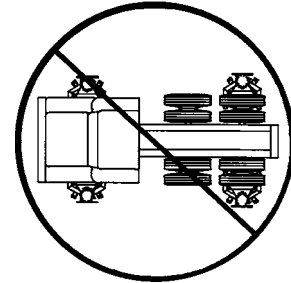

Do not raise an entire vehicle.

**CAUTION:** To reduce the risk of serious personal injury and / or property damage from falling loads, read, understand, and follow all safety precautions. If the operator cannot read English, operating instructions and safety precautions must be read and discussed in the operator's native language.

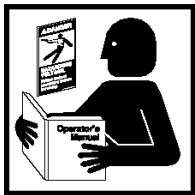

*Si el operador no puede leer inglés, las instrucciones de operación y las precauciones de seguridad deberán leerse y comentarse en el idioma nativo del operador.*

*Si l'utilisateur ne peut lire l'anglais, les instructions et les consignes de sécurité doivent lui être expliquées dans sa langue maternelle.*

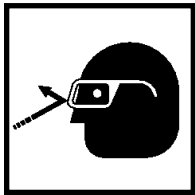

- Wear eye protection that meets ANSI Z87.1 and OSHA standards.
- The Vehicle Lift System is designed to lift over-the-road vehicles with rims of at least 19 inches in diameter. Never use the lifts on vehicles with rims less than 19 inches in diameter.
- Maximum capacity is 10,000 lbs. per lift. Do not use the lift as a stand to raise or support more than 10,000 lbs.
- The lifts are designed to operate on 150 psi shop air. Air pressure higher than 150 psi could result in failure of the vehicle lift system.
- Use the lifts only on a hard, level surface capable of sustaining the load.
- Do not use this lift with any other equipment used to raise a vehicle.
- Use the lifts in pairs, on opposite ends of the same axle.
- Do not use the lifts to raise a vehicle by the frame or structural member; the lift is designed to be used only beneath the vehicle tires.

- To prevent tipping, never raise or lower only one side of a vehicle.
- Do not raise one end of a vehicle if the opposite end is supported by support stands.
- Do not raise an entire vehicle.
- Do not use blocks, non-factory supplied adapters, or cribbing devices with this equipment.
- Do not use this lift as a wheel dolly for the removal of tires.
- Stay out from underneath the vehicle until both lifts are pinned as stands.

## Setup

The vehicle lift system consists of two lifts and one air control unit. Before unpacking the system, provide lifting equipment capable of handling the weight of the units—each unit weighs approx. 513 lbs.

1. Remove banding and packaging material from each lift.
2. Remove the cable ties that hold the downstop release handle, load retention pin, and air hose.
3. Loosen the wire tie holding the cardboard box, and remove the box from the pallet.
4. Using a forklift, shop crane, or other suitable lifting device, carefully remove the lifts from the pallets. Place the lifts on a hard, level surface.

**Assembly**

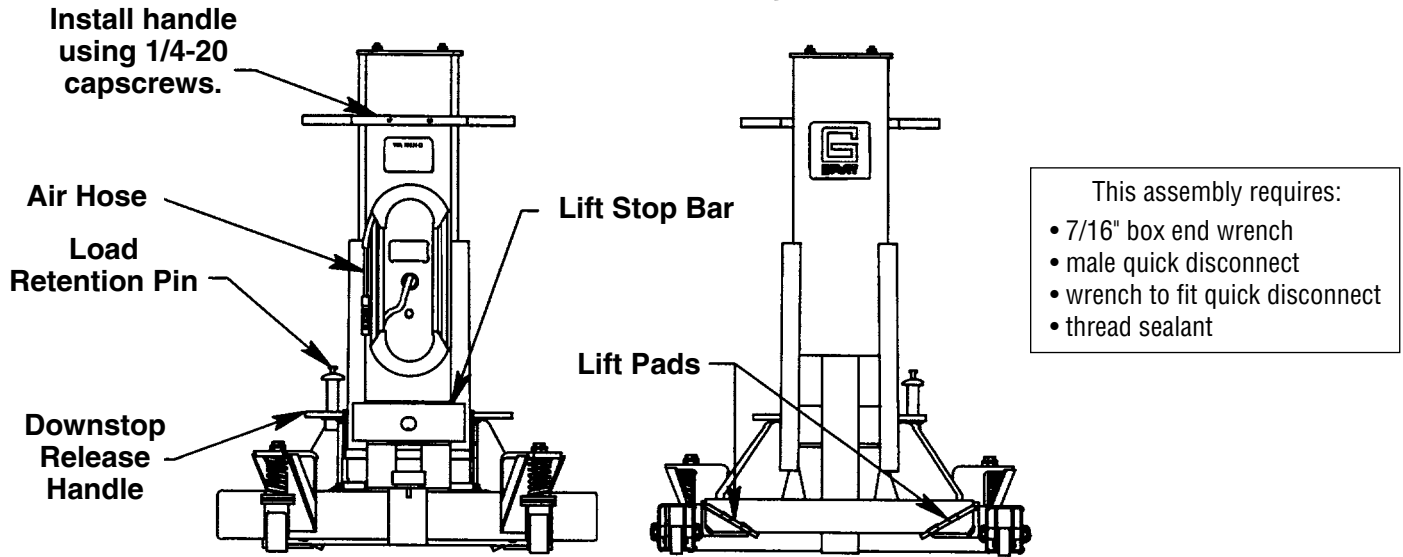

**Figure 1**

**Attaching the Handles**

1. Using two of the 1/4-20 cap screws per lift, attach a handle horizontally across the back of each lift as shown in Figure 1.

**Installing a Quick Disconnect**

1. Install a user-supplied male quick disconnect (with thread sealant) into the air inlet port on the underside of the air control unit.

**Removing the Load Retention Pins**

Use the following steps to remove the load retention pin and engage the downstop on each lift.

1. Position yourself facing the lift. Hold the air control unit with the levers pointing toward the lift and the quick couplers on the underside of the unit.
2. Connect the air hose from the lift to a male quick coupler on the bottom of the unit.
3. Connect shop air (150 psi) to the air inlet port of the unit (see Air Control Unit illustration on Sheet No. 2 of 6).
4. Slowly raise the lift until the load retention pin can be removed.
5. Continue raising the lift until the downstop release handle (Figure 3) can be pushed toward the lift, disengaging the downstop.
6. Place the load retention pin in its holder on the side of the lift.
7. Lower the lift by exhausting all the air from the cylinder.
8. Disconnect the air hose from the air control unit.

**Note:** The recommended clearance between the lift table bottom and the floor is 1/8 inch minimum. If the clearance needs to be adjusted, refer to the section titled Adjusting the Lift Table.

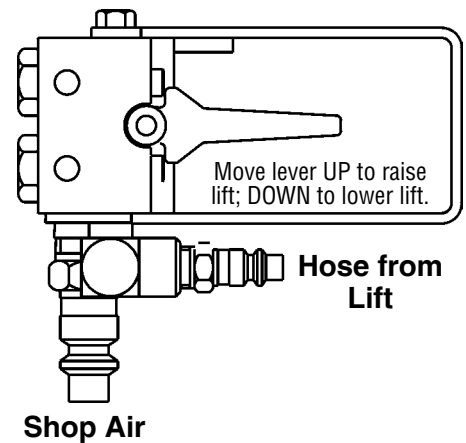

**Figure 2**

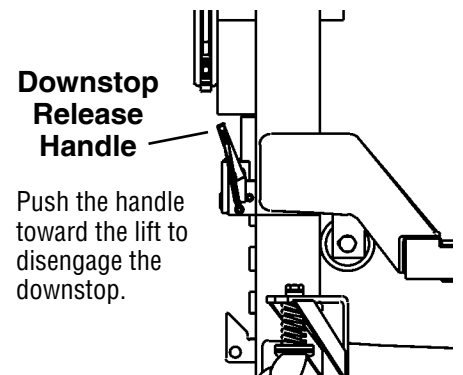

**Figure 3**

## Operating Instructions

1. Park the vehicle on a hard, level surface, and set the parking brake.
2. Verify the vehicle tires are inflated to the correct pressure, to maintain the necessary tire diameter.
3. Position the lifts so the lift pads are cradling the tires **AT OPPOSITE ENDS OF THE SAME AXLE**.
4. Push the lift pad under the tire until the lift table tube meets the tire. See Figure 4.
5. Release the vehicle's parking or air brake, and place the transmission in neutral.
6. Uncoil the air hose from each lift, and route them to connect to the air control unit at either the front or rear of the vehicle.

**⚠ CAUTION: Keep hoses clear of pinch points, and do not run them under the base of a lift because the base lowers slightly as the vehicle is raised. Accidentally cutting off the air supply can cause loss of load, resulting in personal injury.**

7. Position yourself at the front or rear of the vehicle so both lifts are visible. Facing the vehicle, hold the air control unit with the levers pointing toward the vehicle and the quick couplers on the underside of the unit. See Figure 5.
8. Connect the air hose from the lift on your right to the right side of the air control unit. Connect the air hose from the lift on your left to the left side of the air control unit.
9. Connect shop air (150 psi maximum) to the air inlet port of the air control unit.

### Raising a Vehicle

1. Raise the vehicle by lifting UP on both air control levers at the same speed, keeping the vehicle level.
2. Raise the vehicle until it is 2"-4" above the desired working height. **Note:** The vehicle will lower by 2"-4" as the lift downstop lugs engage.
3. Verify the downstop pawls will engage the downstop lugs **AT THE SAME HEIGHT** on each lift. Use the air control unit to adjust the level of the vehicle, if necessary. Figure 6.

### Pinning the Lifts as Stands

1. With the vehicle 2"-4" above the final working height, carefully lower the lifts by pushing both air control levers DOWN at the same time until the downstop pawls engage the closest downstop lugs.
2. Verify the downstop pawls are securely engaged on the downstop lugs of each lift and the raised axle is level. Fig. 6.
3. Remove the load retention pin from its holder on each lift. Insert the pin through the oblong hole in the lift stop bar and fully into the corresponding hole in the downstop lug. Fig. 7.
4. Exhaust the air from both cylinders by pushing both air control levers DOWN at the same time.
5. Disconnect the hoses, and coil them on the hose holders on the back of each lift.

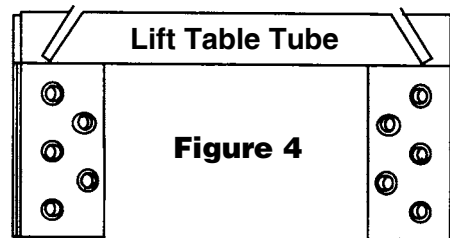

Connect this air line to lift on right side of vehicle.

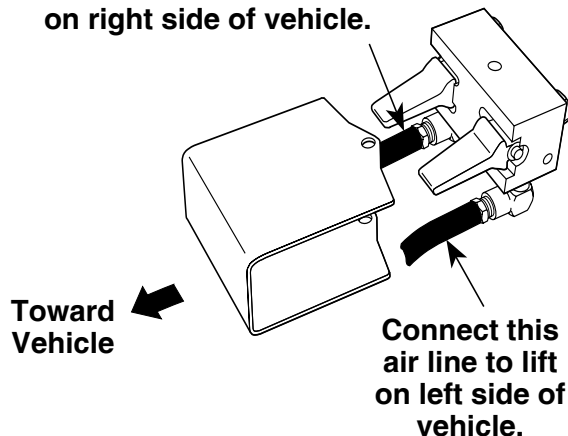

**Figure 5**

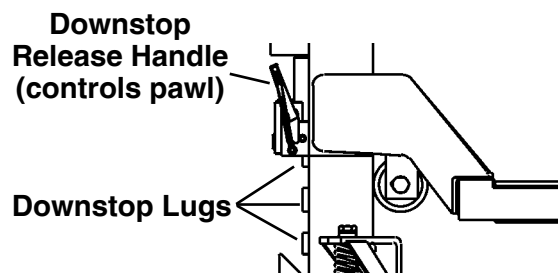

**Figure 6**

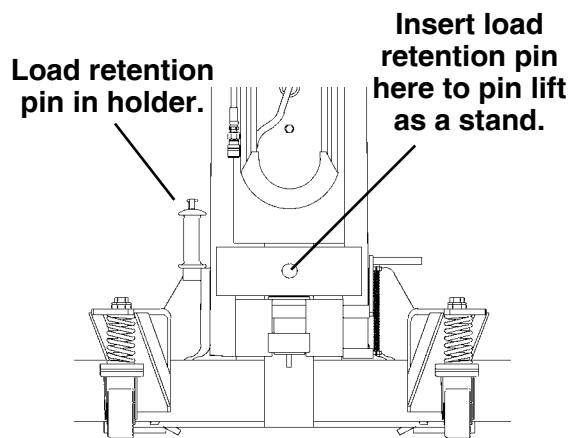

**Figure 7**

## Lowering a Vehicle to the Ground

1. Clear the area under the vehicle of all personnel, tools, and shop equipment.
2. Remove the load retention pins, and insert them in their holders.
3. Uncoil the air hose from each lift, and route them to connect to the air control unit at either the front or the rear of the vehicle.

**⚠ CAUTION: Keep hoses clear of pinch points, and do not run them under the base of a lift because the base lowers slightly as the vehicle is raised. Accidentally cutting off the air supply can cause loss of load, resulting in personal injury.**

4. Position yourself at the front or rear of the vehicle so both lifts are visible. Facing the vehicle, hold the air control unit with the levers pointing toward the vehicle and the quick couplers on the underside of the unit.
5. Connect the air hose from the lift on your right to the right side of the air control unit. Connect the air hose from the lift on your left to the left side of the air control unit. See Figure 5.
6. Connect shop air (145 psi max.) to the air inlet port of the air control unit.
7. Raise both lifts slightly (about 1/2 inch) so the downstop pawls are raised above the downstop lugs.
8. At each lift, release the downstop pawl by pushing the downstop release handle toward the lift. See Figure 8.
9. Lower the lifts by pushing both air control levers **DOWN** at the same time, keeping the vehicle level. Lower the lifts to their lowest position so the downstop pawls will automatically reset.

**Note:** If you decide to raise the vehicle again before it has been fully lowered, you must reset the downstops. To manually reset the downstops, pull the downstop release handle toward you on each of the lifts.

10. Place the vehicle transmission in gear (or park), and engage the brakes.
11. Disconnect the hoses, and coil them on each lift.
12. Move the lifts away from the work area.

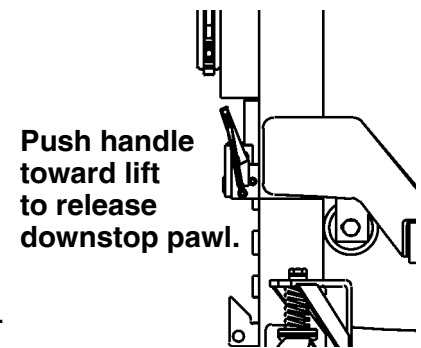

**Figure 8**

## Using the Wheel Lifts with Support Stands

### Transferring a Load to Support Stands

After a vehicle has been raised, and the wheel lifts have been pinned as stands, you may transfer the vehicle to support stands, and remove the wheel lifts.

1. Select support stands that are capable of supporting the weight of the vehicle and are of the same height.
2. Determine lift points an equal distance from the wheel lift on each side of the vehicle. (Use lift points recommended by the vehicle manufacturer for supporting the vehicle.)
3. Clear the area under the vehicle of all personnel.
4. Position the support stands on each side of the vehicle.
5. Remove the load retention pins, and operate the air control unit to lower the vehicle onto the support stands, keeping the vehicle level. **Note:** If the pins do not pull out easily, raise the vehicle just enough to free the pins.
6. When the vehicle is securely supported by the support stands, lower the lifts to their lowest position so the downstop pawls are automatically reset.
7. Disconnect the hoses, and coil them on the hose holders on the back of each lift. Pull the lifts away from the work area.

## Removing Support Stands

1. Position the lifts at opposite ends of the axle to be lowered so the lift pads will cradle the tires when contact is made.
2. Uncoil the air hose from each lift, and route them to connect to the air control unit at either the front or the rear of the vehicle.

 **CAUTION: Keep hoses clear of pinch points, and do not run them under the base of a lift because the base lowers slightly as the vehicle is raised. Accidentally cutting off the air supply can cause loss of load, resulting in personal injury.**

3. Position yourself at the front or rear of the vehicle so both lifts are visible. Facing the vehicle, hold the air control unit with the levers pointing toward the vehicle and the quick couplers on the underside of the unit.
4. Connect the air hose from the lift on your right to the right side of the air control unit. Connect the air hose from the lift on your left to the left side of the air control unit. See Figure 2.
5. Connect shop air (150 psi maximum) to the air inlet port of the air control unit.
6. To raise the lifts, pull UP on both air control levers at the same time. Both lift pads should contact a tire at the same time.
7. Verify both lift pads have securely engaged the tires, and that the lift table tube of each lift meets the side of the tire.
8. Raise the vehicle off the support stands by lifting UP on both air control levers at the same time, keeping the vehicle level.
9. With the vehicle 2"–4" above the final working height, carefully lower the lifts by pushing both air control levers DOWN at the same time until the downstop pawls engage the closest downstop lugs.
10. Verify the downstop pawls are securely engaged on the downstop lugs of each lift, and the raised axle is level. See Figure 6.
11. Remove the load retention pin from its holder on each lift. Insert the pin through the oblong hole in the lift stop bar, and fully into the corresponding hole in the downstop lug.
12. Exhaust the air from both cylinders by pushing both air control levers DOWN at the same time.
13. Disconnect the hoses, and coil them on the hose holders on the back of each lift.
14. Remove the support stands from under the vehicle.



## Maintenance



- ⚠ DANGER:** To prevent serious injury or death resulting from a falling vehicle,
- **NEVER** perform maintenance service or inspections while the Vehicle Lift System is in operation. Remove the lifts from service, and position the lifts so you have clear access to all sides of each lift for inspection or service.
  - Do **NOT** wash the base post. Washing the base post may remove lubricating grease, causing the lift to fail, and the load to tip as it is lowered.

- Never use a damaged lift until all damaged components have been correctly repaired or replaced. Test the lift and verify correct operation before returning it to service.
- Replace damaged air hoses with single-wire reinforced air hoses only. The use of any other type of air hose increases the risk of lift failure should the hose become pinched or damaged.
- Inspect a lift **IMMEDIATELY** after it has been subjected to an abnormal shock or an abnormal load.

## Lubrication

Lubricate the areas shown in the illustration **EVERY MONTH**.

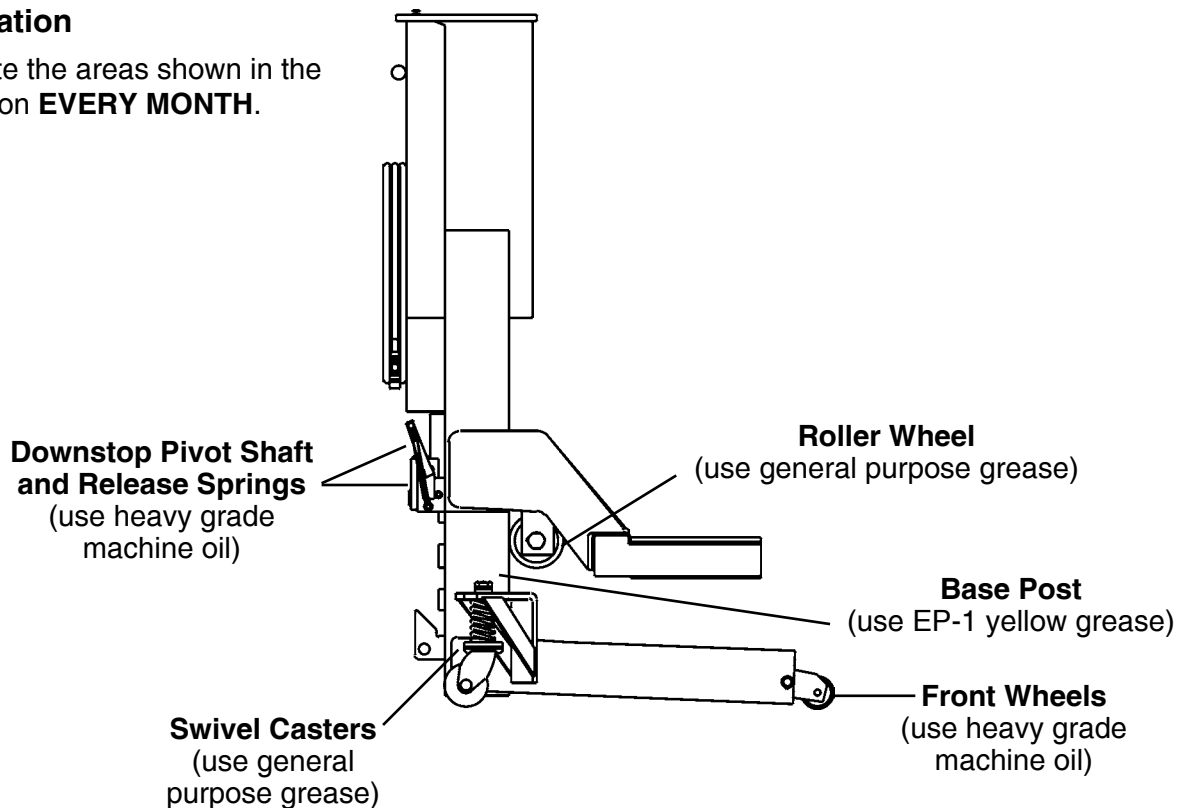

## Inspecting the Vehicle Lift

1. Inspect the lifts **WEEKLY** for any cracks, chips, or signs of excessive wear. Pay special attention to the welds.
2. Inspect the load retention pins **WEEKLY** for deformities or excessive wear. **Note:** *If the deformities or wearing away of material are easily seen without close inspection, it is excessive.*
  - A. Test the load retention pins by inserting them through the lift stop bar and into each downstop lug. If the pin cannot be inserted fully through the lift stop bar and into each of the holes in the downstop lugs in all positions, it is excessively deformed and must be replaced before the lift can be used again.
3. Inspect the holes for the load retention pins in the base post **WEEKLY**. If these holes show excessive elongation or wear on the top or bottom surfaces, they must be repaired before the lift can be used again.

## Maintenance contd.

### Inspecting the Air Hose

1. Inspect the air hoses **DAILY** for any signs of cuts, abrasions, or excessive wear. Replace damaged air hoses with single-wire reinforced air hoses only. The use of any other type of air hose increases the risk of lift failure should the hose become pinched or damaged.
2. Inspect air fittings **DAILY** for cracks or damaged parts. Replace damaged fittings before using the lift.

### Adjusting the Lift Table

The lift has a 1/2-13 hex hd. cap screw mounted inside the top weldment to allow the lift table to be raised or lowered slightly. The cap screw has been preset at the factory to provide 1/4" to 5/16" clearance between the bottom of the lift pads and the floor. To adjust the height of the lift table:

1. Place the lift on a level floor in an open area.
2. Raise the lift to its lowest downstop.
3. Loosen the jam nut, and turn the cap screw a few turns clockwise to raise the lift table, or counterclockwise to lower it.
4. Tighten the jam nut.
5. Lower the lift to its lowest position, and check the lift table height above the floor.
6. Follow steps 1–5 for the other lift. Each lift must have a minimum of 1/8" clearance between the lift table bottom and the floor.

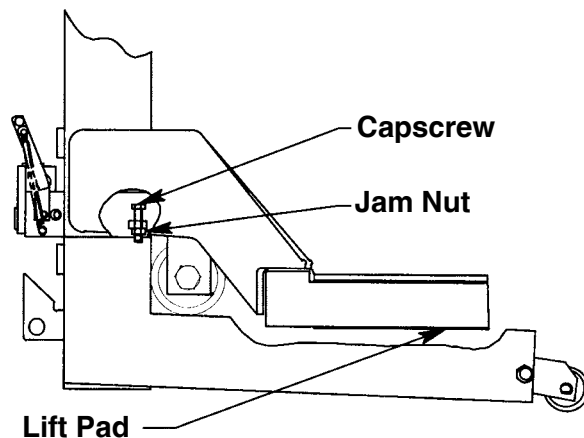

### Cleaning the Air Control Valve

Rust, scale, or dirt from the air lines may become lodged under the rubber seals of the air control module, causing minor air leakage. This leakage could cause the lift to slowly raise or lower even though the air control levers have not been actuated. Use the following procedure to clean the air control module.

1. Disconnect the three air hoses attached to the air control module.
2. Remove the valve bracket.
3. Remove the plug or plugs.
4. Use a stiff wire or pin punch to push the spool out of the valve body.
5. If there is any dirt or foreign material embedded in the rubber seal, remove the screw and cup from the end of the spool, and remove and clean the rubber seal.
6. Turn the seal over, and assemble it into the cup.
7. Use the screw to secure the cup on the end of the spool.
8. Lubricate the spool with a light chassis grease.
9. Insert the spool (with o-ring) into the air inlet spool port; insert the spool (without o-ring) into the air exhaust spool port.
10. Insert the spring(s).
11. Apply thread sealant to the plug(s), and install the plugs into the valve body. Do not overtighten the plugs because the threads are easily damaged.

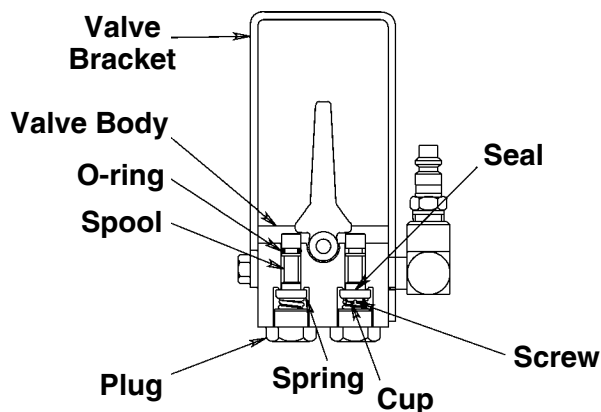

**Troubleshooting Guide**

Repair procedures must be performed in a dirt-free environment by qualified personnel who are familiar with this equipment.

Trouble	Cause	Solution
<b>Will not raise the load</b>	<ol style="list-style-type: none"> <li>1. Insufficient air pressure.</li> <li>2. Insufficient air pressure.</li> <li>3. Lifts are overloaded.</li> <li>4. Air control valve is dirty or damaged.</li> </ol>	<ol style="list-style-type: none"> <li>1. Check pressure at the valve while raising a load; 150 psi is required at the valve to raise the rated capacity of the lift system.</li> <li>2. Air hoses damaged, pinched, or not connected correctly.</li> <li>3. Rated capacity is 10,000 lbs. per lift. Use equipment with sufficient capacity to lift the load.</li> <li>4. Refer to instructions about repairing the air control valve.</li> </ol>
<b>Only one lift raises the load</b>	<ol style="list-style-type: none"> <li>1. Insufficient air pressure.</li> <li>2. Air control valve is dirty or damaged.</li> </ol>	<ol style="list-style-type: none"> <li>1. Air hose damaged, pinched, or not connected correctly.</li> <li>2. Refer to instructions about repairing the air control valve.</li> </ol>
<b>Will not cradle tire</b>	<ol style="list-style-type: none"> <li>1. Tire is under- or over-inflated.</li> <li>2. Lift is not fully lowered.</li> <li>3. Vehicle is overloaded.</li> </ol>	<ol style="list-style-type: none"> <li>1. Check tire inflation.</li> <li>2. Lower the lift completely.</li> <li>3. Use other lifting means.</li> </ol>
<b>Lift will not lower or lowers erratically</b>	<ol style="list-style-type: none"> <li>1. Vehicle parking brake is set or transmission is in gear.</li> <li>2. Insufficient air pressure.</li> <li>3. Insufficient air pressure.</li> </ol>	<ol style="list-style-type: none"> <li>1. Release the vehicle's parking brake and place the transmission in neutral.</li> <li>2. Air hoses not connected correctly.</li> <li>3. Air hoses are pinched. Use other lifting means to remove the load from the lifts; remove hoses from pinch point.</li> </ol>
<b>Lift table hits the floor</b>	<ol style="list-style-type: none"> <li>1. Floor is uneven or rough.</li> <li>2. Lift table height is wrong.</li> </ol>	<ol style="list-style-type: none"> <li>1. Raise the lift to its lowest downstop.</li> <li>2. Refer to instructions about lift table height adjustment.</li> </ol>
<b>Lift raises slowly</b>	<ol style="list-style-type: none"> <li>1. Low air pressure.</li> <li>2. Air control valve is dirty or damaged.</li> <li>3. Lift is overloaded.</li> </ol>	<ol style="list-style-type: none"> <li>1. Set air pressure to 150 psi.</li> <li>2. Refer to instructions about repairing the air control valve.</li> <li>3. Rated capacity is 10,000 lbs. per lift. Use equipment with sufficient capacity to lift the load.</li> </ol>