

Jeep CJ, YJ, and TJ Hardtop Seal Kit

Part Number : 12304.07

Installation Instructions.

This kit is designed to repair or replace the weather seals around your hardtop. Included in the kit are the materials needed to reseal (1) top along the back corner, sides, and across top windshield channel.

- Kit Contains:**
- (1) Tube of rubber repair glue
 - (1) 3/4" wide extruded gasket material
 - (2) Rolls of 1" wide foam tape
 - (1) Hardware hole punch



Instructions: (Rear hardtop corners and sides)

- (1) With your top removed from the vehicle and placed upside down (on a padded surface) use the 1" wide strip of foam tape as the replacement for the rear hardtop side and corner gasket. You must first remove the old gasket and clean surface area with a good solvent (making sure your work area is well ventilated). After the area has been prepped and cleaned attach the 3M adhesive to the hardtop surface. For better protection of the paint and better surface coverage you can angle the gasket into the corners. If adhesion is a problem use supplied tube of rubber sealer (follow the directions on the tube and let dry before remounting the top). After installing cut holes in gasket material where hardware mounting points are located using a razor blade or supplied punch.

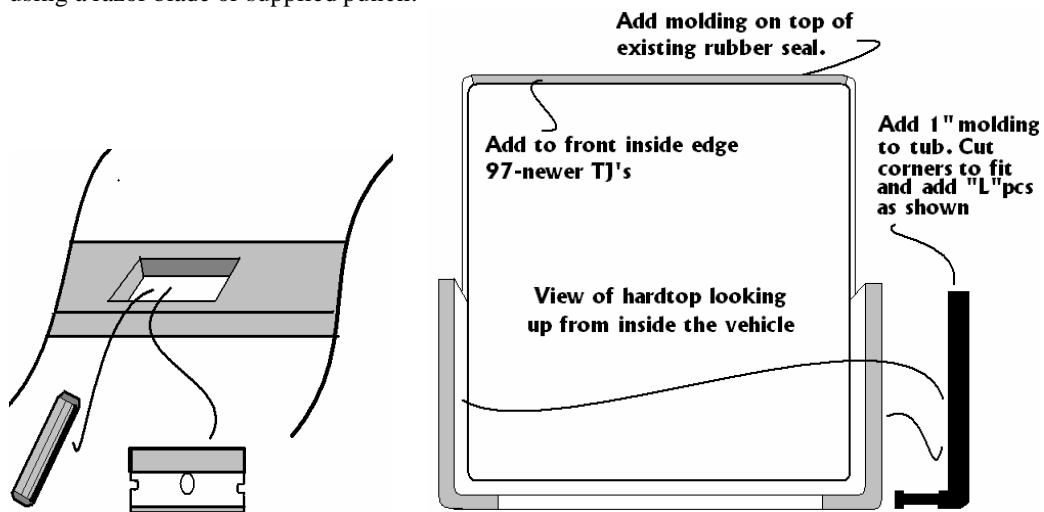

Cut the corners to fit and add the small "L" side pieces as shown. Be sure to cut the four holes on each side using a razor blade or supplied punch. (3 holes for TJ's).

Jeep CJ, YJ, and TJ Hardtop Seal Kit

Installation Instructions.

Instructions: (Front windshield frame)

- (2) **Place the 3/4" strip across the windshield portion of the top.**
It is OK to place this gasket over the existing gasket. Do not Remove the old gasket.
When installing on TJ models, add the strip to the top front lip of the hardtop up to the front edge.
- (3) If installed correctly you will have several inches of the 3/4" gasket material to use at the edges of the top for additional sealing.
- (4) At this time use the tube of rubber glue to affix any other rubber gasket seal that needs repair or patching.

It is important to note that on Wrangler YJ units make sure the small rubber corner finger (rubber molding at the upper corner of the door and windshield) is not folded under when you install your top. If improperly installed wind noise will develop.

NOTE: When door hinges wear they tend to create gaps in between door seals. The most common area is around that a gap will form is up around the corner were the windshield meet the hardtop. Shimming and or realignment of the door may be required to reduce wind noise.

Check the top gasket's fit at these corners. Make sure it's not bunched and is in good condition. If not, add some of the extra 3/4" gasket material to the corners.

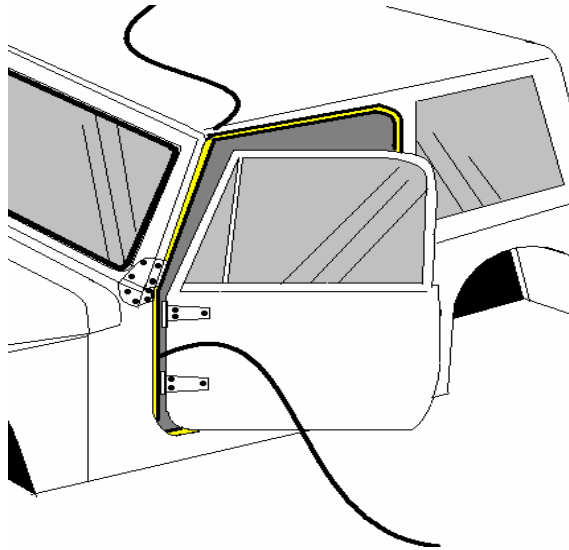

Over time door hinges will wear and cause air to leak between gaps in the door seals. Shimming, realignment, and or possible bending of the top window frame towards the top might be needed for a better seal. If leaks are not corrected wind noise may develop.