

OMEGALIFT™ EQUIPMENT

Low Profile Creeper

Model
91400

Capacity
400 lbs.

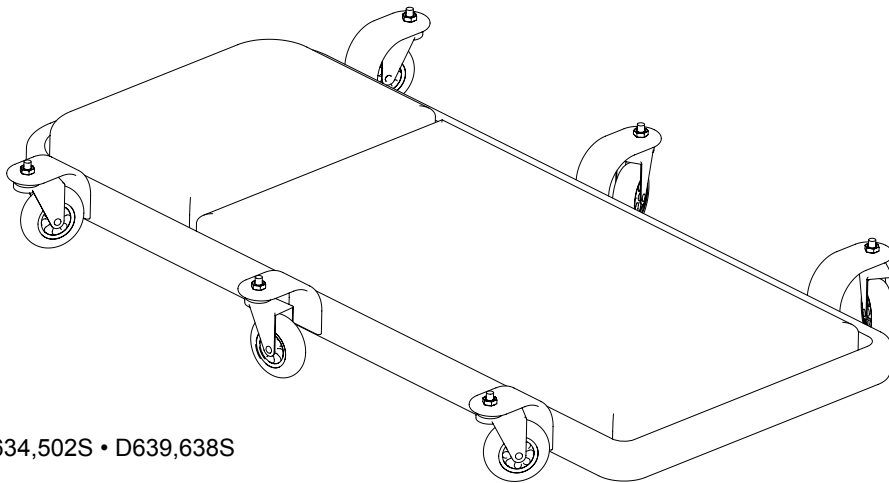

U.S. Patent No's. D634,502S • D639,638S



This is the safety alert symbol. It is used to alert you to potential personal injury hazards. Obey all safety messages that follow this symbol to avoid possible injury or death.



WARNING

To avoid pinch and laceration injuries:

- Keep hands away from pinch and laceration hazards points that are created during use!
- Be alert and sober when using this product!
- Sit centrally on seat pad **ONLY**. NEVER sit on edge!

SFA Companies

Read this manual and follow all the Safety Rules and Operating Instructions before using this product.



WARNING

- Read, understand, and follow all printed materials provided with and on this product before use.
- Do not exceed rated capacity of 400 lbs. Rated capacity consists of: One person, tools, equipment totaling 400 lbs.
- Use on smooth, level, seamless surfaces only.
- Sit down gently. Avoid shock loads caused by jumping or falling onto seat.
- Do not stand on this product.
- This product is not a toy, and is not appropriate for young children.
- Failure to heed these warnings may result in personal injury and/or property damage.

SAFETY AND GENERAL INFORMATION

Save these instructions. For your safety, read, understand, and follow the information provided with and on this jack. The owner and operator of this equipment shall have an understanding of this creeper and safe use/operating procedures before attempting to use. The owner and operator shall be aware that use and repair of this product may require special skills and knowledge. Instructions and safety information shall be conveyed in the operator's native language before use of this jack is authorized. If any doubt exists as to the safe and proper use of this creeper, remove from service immediately.

Inspect before each use. Do not use if broken, bent, cracked, or damaged parts (including labels) are noted. Any creeper that appears damaged in any way, operates abnormally or is missing parts, shall be removed from service immediately. If the creeper has been or suspected to have been subjected to a shock load (a load dropped suddenly, unexpectedly upon it), immediately discontinue use until creeper has been checked by a factory authorized service center. It is recommended that an annual inspection be done by qualified personnel. Labels and Owner's Manuals are available from manufacturer (see Replacement Parts, page 3).

PRODUCT DESCRIPTION

This device is designed to support rated capacity loads consisting of **one person weighing 400 lbs. or less**. It is intended to be used to support and transport, along a **smooth and level surface**, a single person for the purpose of performing automotive maintenance or service. This device **is not** intended, designed or engineered to be used for any other purpose.

 **WARNING:** *Do not use this device for any purpose other than that for which it is expressly intended.*

SPECIFICATIONS

Model	Rated Capacity	Overall Dimensions (L x W x H)
91400	400 lbs	40" x 25-1/2" x 4-3/8"

PREPARATION

Before beginning assembly of this product, make sure all parts are present. Compare parts with package contents list and parts diagram. If any part is missing or damaged, do not attempt to assemble or use the product. Contact customer service for replacement parts.

CASTER ASSEMBLY

Insert caster stud through hole in caster bracket on frame. Attach caster nut and repeat for remaining casters. Ensure casters swivel and roll easily.

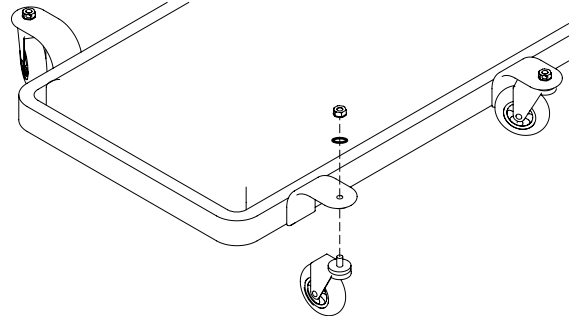

REPLACEMENT PARTS

Available Parts: Please refer to the Parts drawing when ordering parts. Not all components of the creeper are replacement items, but are illustrated as a convenient reference of location and position in the assembly sequence. When ordering parts, give model number, part number and description.

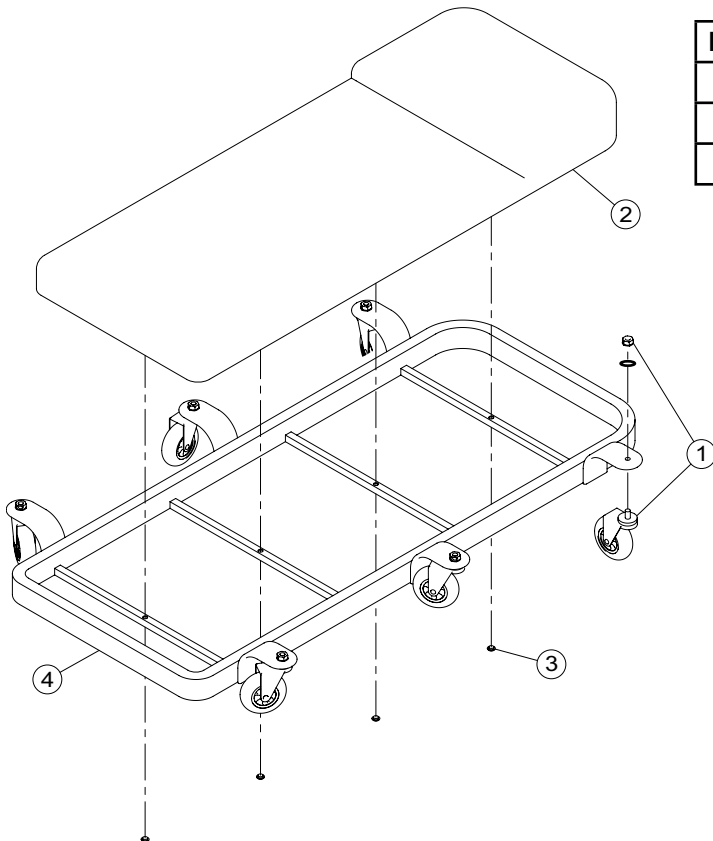

Item	Part No.	Description	Qty
1	91400-1	Poly Caster with fastener	6
2	91400-2	Pad, Omega	1
3	91400-3	Pad Screws	4

ONE YEAR LIMITED WARRANTY

For a period of one (1) year from date of purchase, **SFA Companies** will repair or replace, at its option, without charge, any of its products, which fails due to a defect in material or workmanship under normal usage. This limited warranty is a consumer's exclusive remedy.

Except where such limitations and exclusions are specifically prohibited by applicable law, (1) THE CONSUMER'S SOLE AND EXCLUSIVE REMEDY SHALL BE THE REPAIR OR REPLACEMENT OF DEFECTIVE PRODUCTS AS DESCRIBED ABOVE. (2) **SFA Companies** SHALL NOT BE LIABLE FOR ANY CONSEQUENTIAL OR INCIDENTAL DAMAGE OR LOSS WHATSOEVER. (3) ANY IMPLIED WARRANTIES, INCLUDING WITHOUT LIMITATION THE IMPLIED WARRANTIES OF MERCHANTABILITY AND FITNESS FOR A PARTICULAR PURPOSE, SHALL BE LIMITED TO ONE YEAR, OTHERWISE THE REPAIR, REPLACEMENT OR REFUND AS PROVIDED UNDER THIS EXPRESS LIMITED WARRANTY IS THE EXCLUSIVE REMEDY OF THE CONSUMER, AND IS PROVIDED IN LIEU OF ALL OTHER WARRANTIES, EXPRESS OR IMPLIED. (4) ANY MODIFICATION, ALTERATION, ABUSE, UNAUTHORIZED SERVICE OR ORNAMENTAL DESIGN VOIDS THIS WARRANTY AND IS NOT COVERED BY THIS WARRANTY.

Some states do not allow limitations on how long an implied warranty lasts, so the above limitation may not apply to you. Some states do not allow the exclusion or limitation of incidental or consequential damages, so the above limitation or exclusion may not apply to you. This warranty gives you specific legal rights, and you may also have other rights, which vary from state to state.

