

# OMEGALIFT™ EQUIPMENT

## Aluminum / Steel Hybrid Service Jack

### Operating Instructions & Parts Manual

**Model**

**26017**

**26028** U.S. Patent No. 6,199,379

**26033** U.S. Patent No. 6,199,379

**Capacity**

**1.5 Ton**

**2.5 Ton**

**3 Ton**

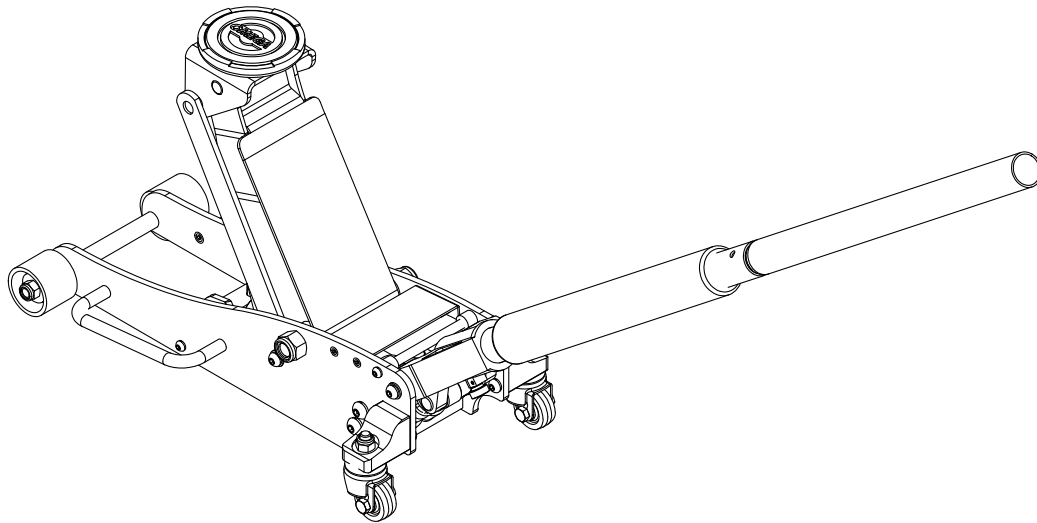

*This is the safety alert symbol. It is used to alert you to potential personal injury hazards. Obey all safety messages that follow this symbol to avoid possible injury or death.*

### **!WARNING**



*To avoid crushing and related injuries:  
NEVER work on, under or around a  
load supported only by a hydraulic  
jack. ALWAYS use an identical pair of  
adequately rated jack stands.*

## SAFETY AND GENERAL INFORMATION

**Save these instructions.** For your safety, read, understand, and follow the information provided with and on this device before using. The owner and/or operator shall have an understanding of the device, its operating characteristics and safety operating instructions before operating the equipment. The owner and/or operator shall be aware that use and repair of this product may require special skills and knowledge. Instructions and safety information shall be read to and discussed with the operator in the operator's native language, making sure that the operator comprehends their contents, before use of this equipment is authorized. If any doubt exists as to the safe and proper use of this device, remove from service immediately.

**Inspect before each use.** Do not use if abnormal conditions such as cracked welds, damaged, loose or missing parts are noted. Any equipment that appears damaged in any way, is found to be worn, or operates abnormally shall be removed from service until repaired. If the equipment has been or is suspected to have been subjected to an abnormal load or shock, immediately discontinue use until inspected by a factory authorized repair facility (contact distributor or manufacturer for list of authorized repair facilities). It is recommended that an annual inspection be made by an authorized repair facility. Labels and Operator's Manuals are available from the manufacturer.

## PRODUCT DESCRIPTION

The OMEGA Lift Aluminum / Steel Hybrid Service Jack is designed to lift, but not support, one end of a vehicle. The jack must be used in conjunction with an identical pair of appropriately rated jack stands. This Jack has a unique feature, which provides fast, no load lifts to the jacking point.

**⚠ WARNING:** *Never use a hydraulic jack as a stand alone support device. After lifting, immediately support the lifted vehicle with an identical pair of appropriately rated jack stands. Never place any portion of your body under the vehicle when lifting or lowering.*

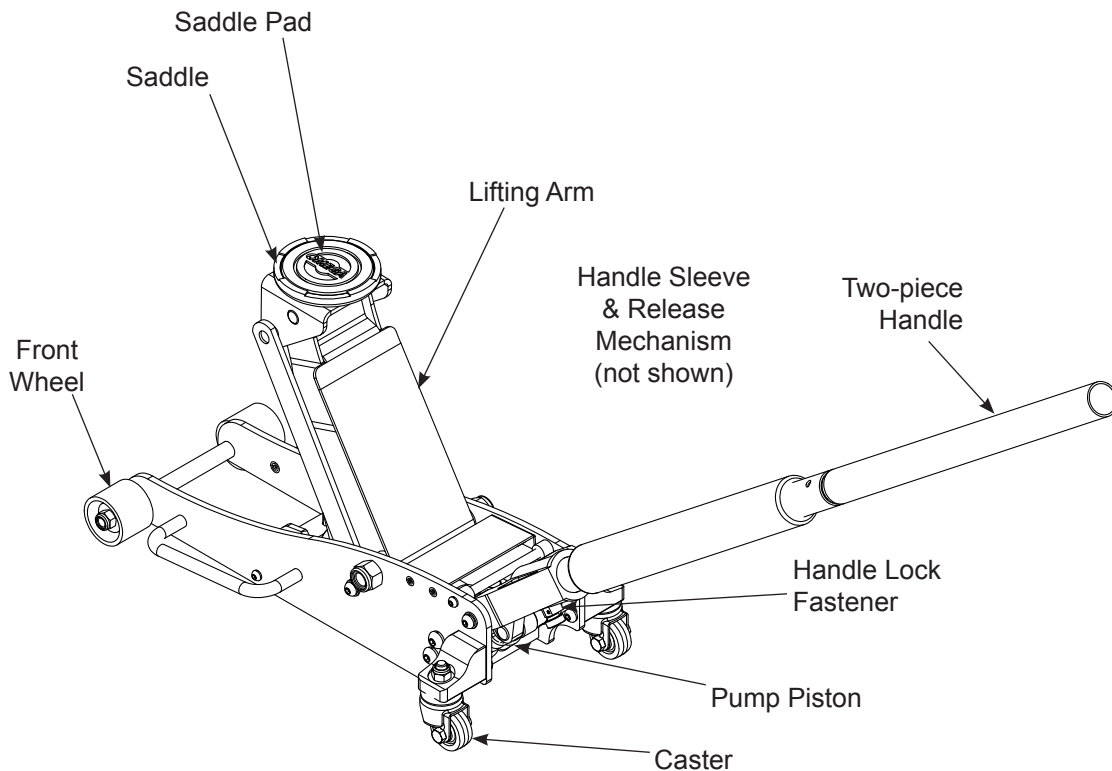

Figure 1 - Service Jack Nomenclature

## ⚠️ WARNING

- Study, understand, and follow all instructions before operating this device.
- Do not exceed rated capacity.
- Use only on hard, level surface capable of supporting the load.
- Lifting device only. Immediately after lifting, support the vehicle with appropriately means.
- Do not move or dolly the vehicle while on the jack.
- Lift only on areas of the vehicle as specified by the vehicle manufacturer.
- No alterations shall be made to this product.
- Failure to heed these markings may result in personal injury and/or property damage.

## ⚠️ WARNING



To avoid crushing and related injuries:

- Never work on, under or around a load supported only by hydraulic jack.
- Chock unlifted tires in both directions.
- Do not use this device to lift, level, lower, support nor move a house, mobile home, travel trailer, camper or any building structure.
- Be alert and sober when using this product. Do not operate under the influence of drugs or alcohol.

## SPECIFICATIONS

Model	Capacity	Jack Size (L x W x H)	Min. Height	Max. Height	Saddle Dia.	Handle Length	Weight
26017	1.5 Ton	21-3/4" x 9-3/8" x 5-5/8"	3-1/2"	14"	3-7/8"	37-1/4"	32.9 lbs
26028	2.5 Ton	26-3/8" x 11-7/8" x 6-1/8"	3-3/4"	18-1/2"	3-7/8"	45-1/8"	57.3 lbs
26033	3 Ton	27-3/4" x 13" x 6-1/4"	3-3/4"	18-1/2"	4-1/2"	47-5/8"	68.3 lbs

## ASSEMBLY/PREPARATION

### Before Use

1. Before using this product, read the operator's manual completely and familiarize yourself thoroughly with the product and its components, and recognize the hazards associated with its use.
2. Verify that the product and application are compatible.
3. Assemble the two-piece handle.
4. Insert the handle into the handle sleeve until it engages the release valve in the bottom of the socket. Tighten the handle lock fastener securely to prevent accidental removal of handle while in use.

**⚠️ WARNING:** Do not lift or carry jack by handle. Handle could dislodge and jack fall, resulting in possible injury or property damage.

5. To familiarize yourself with basic operation, rotate the release valve (pump handle):
  - a. *Clockwise* until firm resistance is felt to further turning. This is the '**CLOSED**' release valve position used to raise the saddle.
  - b. *Counter-clockwise*, but no more than 1/2 turn from the closed position. This is the '**OPEN**' release valve position used to lower the saddle.
6. With saddle fully lowered and release valve closed, pump the handle. If lift arm responds immediately, jack is ready for use. If jack does not respond, follow **Bleeding/Venting Trapped Air** instruction below. Check oil level. Proper oil level should be approximately 6mm below valve opening. Reinstall Air Vent Screw.
7. Ensure that jack rolls freely. Ensure the pump operates smoothly by raising and lowering the unloaded saddle throughout the entire lifting range before putting into service. Replace worn or damaged parts and assemblies with Factory Authorized Replacement parts only.

### Bleeding/Venting Trapped Air

With the release valve in the OPEN position (step 5b. above) and saddle fully lowered, locate and remove the Air Vent Screw. Pump handle 6 to 8 full strokes. This will help release pressurized air which may be trapped within the reservoir. Reinstall the Air Vent Screw and check operation.

## OPERATION

### Lifting

1. Follow the vehicle manufacturer's recommended guidelines for lifting. Engage the vehicle's emergency brake and chock the unlifted wheels in both directions to prevent inadvertent movement.
2. Close the release valve by turning the pump handle clockwise until firm resistance is felt.
3. Refer to the vehicle manufacturer owner's manual to locate approved lifting points on the vehicle. Center jack saddle under lift point.
4. Pump handle until saddle contacts lift point. To lift, continue pumping handle until load reaches desired height.
5. Immediately transfer the load to appropriately rated jack stands.

### Lowering

 **WARNING:** *Clear all tools and personnel before lowering vehicle. Open release valve slowly. The further the pump handle is turned counter-clockwise, the faster the load will descend. Maintain control of load at all times.*

1. Raise load high enough to clear the jack stands.
2. Remove jack stands.
3. Slowly turn the handle counter-clockwise, but no more than 1/2 full turn.  
*If the load fails to lower:*
  - a. Use another jack to raise the vehicle high enough to reinstall jack stands.
  - b. Remove the malfunctioning jack and then the jack stands.
  - c. Use the functioning jack to lower the vehicle.
4. After removing jack from under the vehicle, fully lower the saddle to reduce ram exposure to rust and contamination.

## MAINTENANCE

**NOTICE:** *Use premium quality hydraulic jack oil. Avoid mixing different types of fluid and do not use brake fluid, turbine oil, transmission fluid, motor oil or glycerin. Improper fluid can cause premature failure of the jack and the potential for sudden and immediate loss of load.*

### Adding oil

Correct oil level allows the saddle to reach its advertised maximum height and its advertised minimum height.

**NOTICE:** *Too much oil will prevent saddle from lowering completely. Too little oil will not allow the saddle to raise completely.*

1. With saddle fully lowered set jack in its upright, level position. Remove Air Vent Screw.
2. Fill until oil is approximately 6mm below valve opening. Reinstall Air Vent Screw.

### Changing oil

For best performance and longest life, replace the complete fluid supply at least once per year.

1. With saddle fully lowered, remove the Air Vent Screw.
2. Lay the jack on its side and drain the fluid into a suitable container.

**NOTICE:** *Dispose of hydraulic fluid in accordance with local environmental regulations.*

3. Fill until oil is approximately 6mm below valve opening. Reinstall Air Vent Screw.
4. Perform **Bleeding/Venting Trapped Air** procedure, page 3.

### Lubrication

A periodic coating of light lubricating oil to pivot points, axles and hinges will help to prevent rust and assure that wheels, casters and pump assemblies move freely.

**Cleaning**

Periodically check the pump piston and ram for signs of rust or corrosion. Clean as needed and wipe with an oily cloth.

**NOTICE:** *Do not use sand paper or abrasive material on ram and pump piston surfaces.*

**Storage**

When not in use, store the jack with saddle fully lowered.

**TROUBLESHOOTING**

Symptom	Possible Causes	Corrective Action
Jack will not lift load	<ul style="list-style-type: none"> <li>• Release valve not tightly closed</li> <li>• Load is too heavy</li> </ul>	<ul style="list-style-type: none"> <li>• Ensure release valve tightly closed</li> <li>• Consider higher capacity jack</li> </ul>
Jack will lift, but not maintain pressure	<ul style="list-style-type: none"> <li>• Release valve not tightly closed</li> <li>• Hydraulic unit malfunction</li> </ul>	<ul style="list-style-type: none"> <li>• Ensure release valve tightly closed</li> <li>• Discontinue use, contact OMEGA Lift technical service</li> </ul>
Jack will not lower after unloading	<ul style="list-style-type: none"> <li>• Reservoir overfilled</li> <li>• Linkages binding</li> </ul>	<ul style="list-style-type: none"> <li>• Drain fluid to proper level</li> <li>• Clean and lubricate moving parts</li> </ul>
Poor lift performance	<ul style="list-style-type: none"> <li>• Fluid level low</li> <li>• Air trapped in system</li> </ul>	<ul style="list-style-type: none"> <li>• Ensure proper fluid level</li> <li>• Follow <b>Bleeding/Venting Trapped Air</b> procedure on page 3</li> </ul>
Will not lift to full extension	<ul style="list-style-type: none"> <li>• Fluid level low</li> </ul>	<ul style="list-style-type: none"> <li>• Ensure proper fluid level</li> </ul>

# REPLACEMENT PARTS

Not all components of the jack are replacement items, but are illustrated as a convenient reference of location and position in the assembly sequence. When ordering parts, give Model number, serial number and parts description.

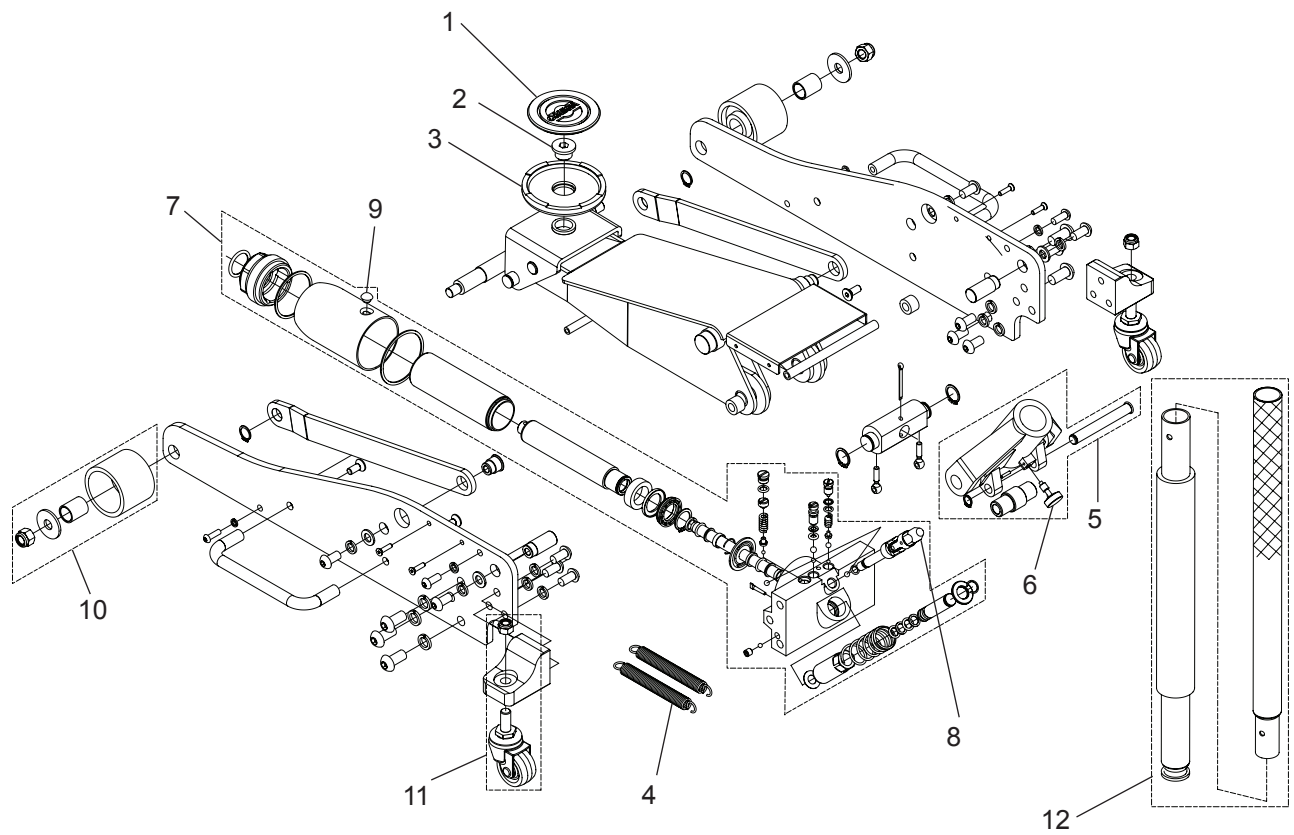

Figure 2 - Replacement Parts Illustration for Model 26017, 26028, 26033  
(26028 Shown)

**Replacement Parts List model 26017, 26028, 26033**

Item	Part No.			Description	Qty
	26017	26028	26033		
1	0002-02-31	0002-02-3	0002-02-3	Saddle Pad	1
2	0002-03-1	0002-03-1	0002-03-1	Saddle Holding Block	1
3	0002-01-31	0002-01-31	0002-01-31	Saddle	1
4	0003-02-1	0003-02-4	0003-02-4	Return Spring	2
5	QY156H-K09A	QY252-K09A	QY302-K09A	Handle Sleeve Assembly	1
6	0500-04-1	0500-04-2	0500-04-2	Handle Lock Fastener	1
7	QY156H-K02A	QY252-K02A	QY302-K02A	Hydraulic Unit	1
8	QY156H-K08	QY252-K08	QY302-K08A	Release Valve Assembly	1
9	0105-03-1	0105-05-1	0105-05-1	Air Vent Screw	1
10	QY156H-K03A	QY252-K03A	QY302-K03A	Front Wheel Assembly	2
11	QY156H-K04A	QY252-K04A	QY302-K04A	Rear Caster Assembly	2
12	QY156H-K05	QY252-K05	QY302-K05	Handle Assembly	1
-	QY156H-K00	QY252-K00	QY302-K00	Repair Kit, Hydraulic	-

## ONE YEAR LIMITED WARRANTY

For a period of one (1) year from date of purchase, **SFA Companies** will repair or replace, at its option, without charge, any of its products which fails due to a defect in material or workmanship under normal usage. This limited warranty is a consumer's exclusive remedy.

Except where such limitations and exclusions are specifically prohibited by applicable law, (1) THE CONSUMER'S SOLE AND EXCLUSIVE REMEDY SHALL BE THE REPAIR OR REPLACEMENT OF DEFECTIVE PRODUCTS AS DESCRIBED ABOVE. (2) **SFA COMPANIES** SHALL NOT BE LIABLE FOR ANY CONSEQUENTIAL OR INCIDENTAL DAMAGE OR LOSS WHATSOEVER. (3) ANY IMPLIED WARRANTIES, INCLUDING WITHOUT LIMITATION THE IMPLIED WARRANTIES OF MERCHANTABILITY AND FITNESS FOR A PARTICULAR PURPOSE, SHALL BE LIMITED TO ONE YEAR, OTHERWISE THE REPAIR, REPLACEMENT OR REFUND AS PROVIDED UNDER THIS EXPRESS LIMITED WARRANTY IS THE EXCLUSIVE REMEDY OF THE CONSUMER, AND IS PROVIDED IN LIEU OF ALL OTHER WARRANTIES, EXPRESS OR IMPLIED. (4) ANY MODIFICATION, ALTERATION, ABUSE, UNAUTHORIZED SERVICE OR ORNAMENTAL DESIGN VOIDS THIS WARRANTY AND IS NOT COVERED BY THIS WARRANTY.

Some states do not allow limitations on how long an implied warranty lasts, so the above limitation may not apply to you. Some states do not allow the exclusion or limitation of incidental or consequential damages, so the above limitation or exclusion may not apply to you. This warranty gives you specific legal rights, and you may also have other rights, which vary from state to state.

---

**OMEGALIFT™**  
EQUIPMENT

Choose reliable garage accessories offered on our website.