

Please read and save these instructions. Read through this owner's manual carefully before using product. Protect yourself and others by observing all safety information, warnings, and cautions. Failure to comply with instructions could result in personal injury and/or damage to product or property. Please retain instructions for future reference.



FOLDING ENGINE CRANE

UNPACKING

After unpacking unit, inspect carefully for any damage that may have occurred during transit. Check for loose, missing, or damaged parts. If any damage is observed, a shipping damage claim must be filed with carrier. Do not use Engine Crane if broken, bent, cracked or damaged parts (including labels) are noted. Any Engine Crane that appears damaged in any way, operates abnormally or is missing parts should be removed from service immediately. If you suspect that the Engine Crane was subjected to a shock load (a load that was dropped suddenly, unexpectedly, etc.) immediately discontinue use until it has been checked by a factory authorized service center.



⚠ WARNING

The following safety information is provided as a guideline to help you operate your Engine Crane under the safest possible conditions. Any tool or piece of equipment can be potentially dangerous to use when safety or safe handling instructions are not known or not followed. The following safety instructions are to provide the user with the information necessary for safe use and operation. Please read and retain these instructions for the continued safe use of your tool. Failure to follow instructions listed below may result in serious injury. In addition, make certain that anyone that uses the equipment understands and follows these safety instructions as well.

Explanation of Safety Signal Words

⚠ WARNING : Indicates a potentially hazardous situation which, if not avoided, could result in death or serious injury.

⚠ CAUTION : Indicates a potentially hazardous situation which, if not avoided, may result in minor or moderate injury.

CAUTION : Used without the safety alert symbol indicates a potentially hazardous situation which, if not avoided, may result in property damage.

NOTES : Provide clarity and helpful information.

Thank you very much for choosing an OEMTOOLS Product!

For future reference, please complete the owner's record below:

Model: _____ **Purchase Date:** _____

Save the receipt, warranty and these instructions. It is important that you read the entire manual to become familiar with this product before you begin using it. This product is designed for certain applications only. OEMTOOLS cannot be responsible for issues arising from modification. We strongly recommend this product is not modified and/or used for any application other than that for which it was designed. If you have any questions relative to a particular application, DO NOT use the product until you have first contacted OEMTOOLS to determine if it can or should be performed on the product.



FOLDING ENGINE CRANE



IMPORTANT INSTRUCTIONS AND SAFETY RULES

1. Know your tool. Read this manual carefully. Learn the tool's applications and limitations, as well as, potential hazards specific to it.
2. Keep work area clean and well lit. Cluttered or dark work areas invite accidents.
3. Keep children away. All children should be kept away from the work area. Never let a child handle a tool without strict adult supervision.
4. Do not operate this tool if under the influence of alcohol or drugs. Read warning labels on prescriptions to determine if your judgment or reflexes are impaired while taking drugs. If there is any doubt, do not attempt to operate.
5. Use safety equipment. Eye protection should be worn at all times when operating this tool. Use ANSI approved safety glasses. Everyday eyeglasses are NOT safety glasses. Dust mask, non-skid safety shoes, hard hat or hearing protection should be used in appropriate conditions.
6. Wear proper apparel. Loose clothing, gloves, neck-ties, rings, Bracelets or other jewelry may present a potential hazard when operating this tool. Keep all apparel clear of the tool.
7. Don't overreach. Keep proper footing and balance at all times when operating this tool.
8. Check for damage. Check your tool regularly. If part of the tool is damaged it should be carefully inspected to make sure that it can perform its intended function correctly. If in doubt, the part should be repaired. Refer all servicing to a qualified technician. Consult your dealer for advice.
9. Keep away from flammables. Do not attempt to operate this tool near flammable materials or combustibles. Failure to comply may cause serious injury or death.
10. Store idle tools out of the reach of children and untrained persons. Tools may be dangerous in the hands of untrained users.
11. Maintain tools with care.
12. Keep tools dry and clean.
13. Properly maintained tools are less likely to bind and are easier to control. Do not use a damaged tool. Tag damaged tools "Do not use" until repaired.
14. Check for misalignment or binding of moving parts, breakage of parts, and any other condition that may affect the tool's operation.
15. If damaged, have the tool serviced before using. Many accidents are caused by poorly maintained tools.
16. Use only accessories that are recommended by the manufacturer for your model. Accessories that may be suitable for one tool may become hazardous when used on another tool.
17. Tool service must be performed only by qualified repair personnel. Service or maintenance performed by unqualified personnel could result in a risk of injury.
18. When servicing a tool, use only identical replacement parts. Use of unauthorized parts or failure to follow maintenance instructions may create a risk of injury.
19. Maintain a safe working environment. Keep the work area well lit. Make sure there is adequate surrounding workspace. Keep the work area free of obstructions, grease, oil, trash, and other debris. Do not use this product in a damp or wet location.
20. Maintain labels and nameplates on this product. These carry important information. If unreadable or missing, contact OEM for a replacement.
21. Keep the handle dry, clean, and free from brake fluid, oil, and grease.
22. Before use, read and understand all warnings, safety precautions, and instructions as outlined in the vehicle manufacturer's service manual. It is beyond the scope of this manual to properly describe the correct procedure and test data for each vehicle.
23. Always perform vehicle service in a properly ventilated area. Never run an engine without proper ventilation for its exhaust. Stop work and take necessary steps to improve ventilation in the work area if you develop momentary eye, nose, or throat irritation as this indicates inadequate ventilation.
24. Engine parts that are in motion and unexpected movement of a vehicle can injure or kill. When working near moving engine parts, wear snug fit clothing and keep hands and fingers away from moving parts. Keep hoses and tools clear of moving parts. Always stay clear of moving engine parts. Hoses and tools can be thrown through the air if not kept clear of moving engine parts.



FOLDING ENGINE CRANE

25. The unexpected movement of a vehicle can injure or kill. When working on vehicles always set the parking brake or block the wheels.
26. Avoid accidental fire and/or explosion. Do not smoke near engine, fuel and battery components.
27. The warnings, precautions, and instructions discussed in this manual cannot cover all possible conditions and situations that may occur. The operator must understand that common sense and caution are factors which cannot be built into this product, but must be supplied by the operator.
28. For safety purposes and the prevention of damage to expensive components it is advised that the user have an understanding of basic automotive repair and a working knowledge of automotive systems.
29. We believe the information contained herein to be reliable. However, general technical information is given by us without charge and the user shall employ such information at their own discretion and risk. We assume no responsibility for results or damages incurred from the use of such information in whole or in part. Always refer to specific instructions and technical information supplied by vehicle manufacturer.
30. The manufacturer declines any and all responsibility for damage to vehicles or components if said damage is the result of unskillful handling by the operator or of failure to observe the basic safety rules set forth in the instruction manual.
31. This equipment is intended only for professional use by personnel trained in performing the service functions for which it is has been designed.
32. This equipment is designed for servicing a variety of vehicles in a safe, convenient manner. However, differences in vehicle makes and models may make it impossible to use this equipment as it is intended. Do not attempt to force the use of this equipment on an application for which it is not designed to perform.
33. The procedures documented in this manual are to serve as guidelines for the use of this equipment.
34. In addition to these guidelines, always follow the manufacturer's recommended procedures when servicing each unique vehicle.

35. The use of this equipment is simple and straightforward if you follow the instructions. When operating this equipment, use common sense, and always stop to think before using a engine crane or lifting a vehicle.

PRODUCT SPECIFICATIONS

Rated Capacity:	2 Ton		
Ram Travel Stroke:	18"		
Base Length:	70"		
Base Width (Front):	41"		
Base Width (Rear):	32"		
Boom Position /Ton	Min. Hook /Height	Max. Hook /Height	Hook to Ram
0.5	0	74.5"	40"
1	0	71"	34"
1.5	6.5"	67"	27"
2	12"	64"	20.5"



FOLDING ENGINE CRANE

PRODUCT DESCRIPTION

This engine crane is intended to be used to remove, install and transport in the lowest position, automotive and light truck engines and engine assemblies. It must be used with appropriately rated engine leveler, sling and/or chains which are NOT INCLUDED. After removing, immediately transfer the load to a work station or engine stand. Do not exceed rated capacity.

NEVER use for any purpose other than those uses outlined above!

WARNING

1. Verify that the product and application are compatible.
2. Before using this product, read the operator's manual completely and familiarize yourself thoroughly with the product, its components and recognize the hazards associated with its use.
3. Wear appropriate safety gear, including heavy duty work gloves and ANSI-approved safety goggles during use.
4. Do not exceed the weight capacity of the engine crane. Make sure weight is evenly distributed. Be aware of dynamic loading! Sudden load movement may briefly create excess load causing product failure. Exceeding the maximum capacity for this product is dangerous and can lead to serious injury or property damage.
5. Always evaluate your task before using this engine crane. Use as intended only.
6. Lifting or supporting a vehicle or its components, even within weight limit, can create an offbalance situation, causing the engine crane to tip over and MAY lead to serious personal injury or property damage.
7. Use as intended only. Do not use for lifting human weight. Keep clear of raised load.
8. Use only on a hard, level and flat surface capable of bearing the combined weight of the engine crane, load being lifted, the operator and any tools being used.

WARNING

9. If you are working and the load becomes off-balance and/or the engine crane begins to tip over, DO NOT ATTEMPT TO CATCH OR LIFT

THE LOAD WHEN FALLING. SERIOUS PERSONAL INJURY CAN RESULT! In this event, clear the area as quickly and safely as possible in order to avoid injury from the falling load, including getting hit with flying fragments.

10. Before each use, inspect the general condition of the engine crane. If a problem occurs, have the problem corrected before further use.

TO PREVENT SERIOUS INJURY: DO NOT USE A DAMAGED OR MALFUNCTIONING ENGINE CRANE

11. If in doubt about the safety of your project, we advise you to have the work done by a professional familiar with applicable safety practices.

ASSEMBLY

1. Make sure all parts are present (refer to assembly diagram). If any parts are missing or damaged, contact customer service.
2. Attach caster assemblies (6) to base (1) using bolts and washers, lock washer and nuts (2, 3, 4, 5), then attach caster assembly (10) using bolts (11).
3. Install casters (6) to front legs (12) using bolts, washers, lock washers and nuts (2, 3, 4, 5).
4. Attach two front legs (12) to base (1) using 4 pins, (8) and 4 retaining clip (9).
5. Attach upright (19) to base (1) using two bolts, washer and nuts (13, 14, 15). Upright must lean towards the rear of the base as shown. Leave nuts finger tight.
6. Attach two braces (20) to upright (19) with bolt, washer & nut (16, 17, 21). Leave nut finger tight.
7. Attach the bottom of braces (20) to inside of base (1) using two each bolts & nuts (18, 16, 17).
8. Attach handle (23) to base (1) using bolts, washers and lock washer (3, 4, 5).
9. Tighten all bolts from upright (19) to base (1), braces (20) to upright (19), and braces (20) to base (1).
10. Attach hydraulic unit (30) to the mounting bracket using bolts, washers & nuts (16, 17, 18). Handle socket of hydraulic unit must face the front of the base as shown. Lean hydraulic unit assembly back against upright.
11. Connect boom (24) to upright using bolt, washer & nut (16, 17, 24).
12. Hold boom (24) and pivot hydraulic unit (30) out away from upright. Attach the ram of hydraulic unit to boom with bolt, washer & nut (16, 17, 25). Tighten nut.



FOLDING ENGINE CRANE

13. Slide boom extension (26) into boom and secure in retracted position using bolt, washer and nut (13, 14, 15). Three positions available: 1/2 ton, 3/4 ton, and 1 ton position.
14. Insert hook and chain (8) to boom extension using bolt, washer & nut (13, 14, 27). Re-tighten all fasteners.
15. **NOTE: CHECK ALL FASTENERS FOR TIGHTNESS. TIGHTEN WHEN ASSEMBLY IS COMPLETE.**

TO FOLD FOR STORAGE:

1. Remove forward most retaining clip and pin (8) and (9).
2. Raise leg until it nears vertical, reinstall pin (8) and retaining clip (9).
3. Repeat for other leg.

OPERATION BEFORE FIRST USE

1. To familiarize yourself with basic operation, turn the release valve lever:
 - a. Clockwise until firm resistance is felt to further turning. This is the 'CLOSED' release valve position used to raise the ram plunger.
 - b. Counterclockwise, but no more than 2 turns from the closed position. This is the 'OPEN' release valve position used to lower the ram plunger.

WARNING

WARNING: Clear all tools and personnel before lowering load. Open release valve slowly. The further handle is turned counterclockwise, the faster the load will descend. Maintain control of the load at all times.

1. With ram plunger fully retracted, remove the oil filler plug. Insert the handle into the handle sleeve, and then pump 6 to 8 strokes. This will help release any pressurized air, which may be trapped within the reservoir. Ensure the oil level is just below the oil filler hole. Reinstall the oil filler plug.
2. Check to ensure that crane rolls freely and that the pump and release valve operate smoothly. Raise and lower the unloaded crane throughout the lifting range before putting into service.

WARNING

WARNING: Use of this engine crane is limited to lifting, lowering, and transporting in the lowest possible position, automotive and light truck engines. It is NOT and should never be used as a work station.

WARNING: Always refer to vehicle service manual and/or shop manual for location of appropriate engine lift points and removal procedures.

WARNING: Lift only on areas of the engine as specified by the vehicle manufacturer.

WARNING: Never load the crane with an engine that extends beyond an imaginary line drawn connecting the centerlines of the front and rear wheel/caster axles!

1. Ensure that the load does not exceed the rated capacity of your chosen boom and leg position.
2. Secure appropriately rated engine leveler, chain or sling assembly (sold separately) to the vehicle manufacturers' recommended engine lift points.
3. Secure the engine crane safety hook assembly to the engine leveler, chain or sling assembly.
4. Refer to vehicle service manual and/or shop manual for location of appropriate engine lift points and removal procedures. Each engine removal/installation may require different tools, procedures, and level of expertise.
5. When ready to remove engine, turn release valve clockwise until firm. Pump handle until load is high enough to clear vehicle. Before moving, ensure the load is:
 - a. At the lowest practical position and always below the center of gravity.
 - b. Prevented from swinging and inadvertent shifing.

WARNING

WARNING: Never put any portion of your body under a load supported by the engine crane. Keep crane on hard, smooth, level surface. Before moving crane, lower the boom as far below horizontal as possible, yet still allowing movement!

1. Remove engine, then immediately transfer the engine to appropriate engine support device (engine stand). Turn release valve lever counterclockwise to lower the load, but never more than 2 full turns.
- Control the rate of descent of the load at all times.** The more you open the release valve, the faster the load descends.
2. Ensure stand is secure before working on or around it.



FOLDING ENGINE CRANE

Use caution when troubleshooting a malfunctioning engine crane. Stay well clear of the supported load. Completely resolve all problems before use. If the engine crane is malfunctioning, have a qualified technician inspect and repair the engine crane before use.

MAINTENANCE

A periodic coating of light lubricating oil to pivot points, adjusting points, etc. will help to prevent rust and assure that all components move freely.

STORAGE

Always store the engine crane in a well-protected area where it will not be exposed to inclement weather, corrosive vapors, abrasive dust, or any other harmful elements.



FOLDING ENGINE CRANE

PARTS LIST

Figure	Description	Quantity
1	Base Frame	1
2	Nut	16
3	Lock Washer	26
4	Washer	26
5	Bolt	16
6	Caster Assembly	4
7	Bolt	2
8	Pin	4
9	R-Pin	4
10	Caster Assembly	2
11	Bolt	8
12	Extension Leg	2
13	Nut	4
14	Washer	4
15	Bolt	3
16	Washer	6
17	Nut	6
18	Bolt	1
19	Post	1
20	Support	2
21	Bolt	1
22	Bolt	1
23	Pulling Handle	1
24	Boom	1
25	Bolt	1
26	Boom Extension	1
27	Bolt	1
28	Chain	1
29	Hook	1
30	Jack	1
31	Handle Cover	1
32	Handle	1

PARTS DIAGRAM

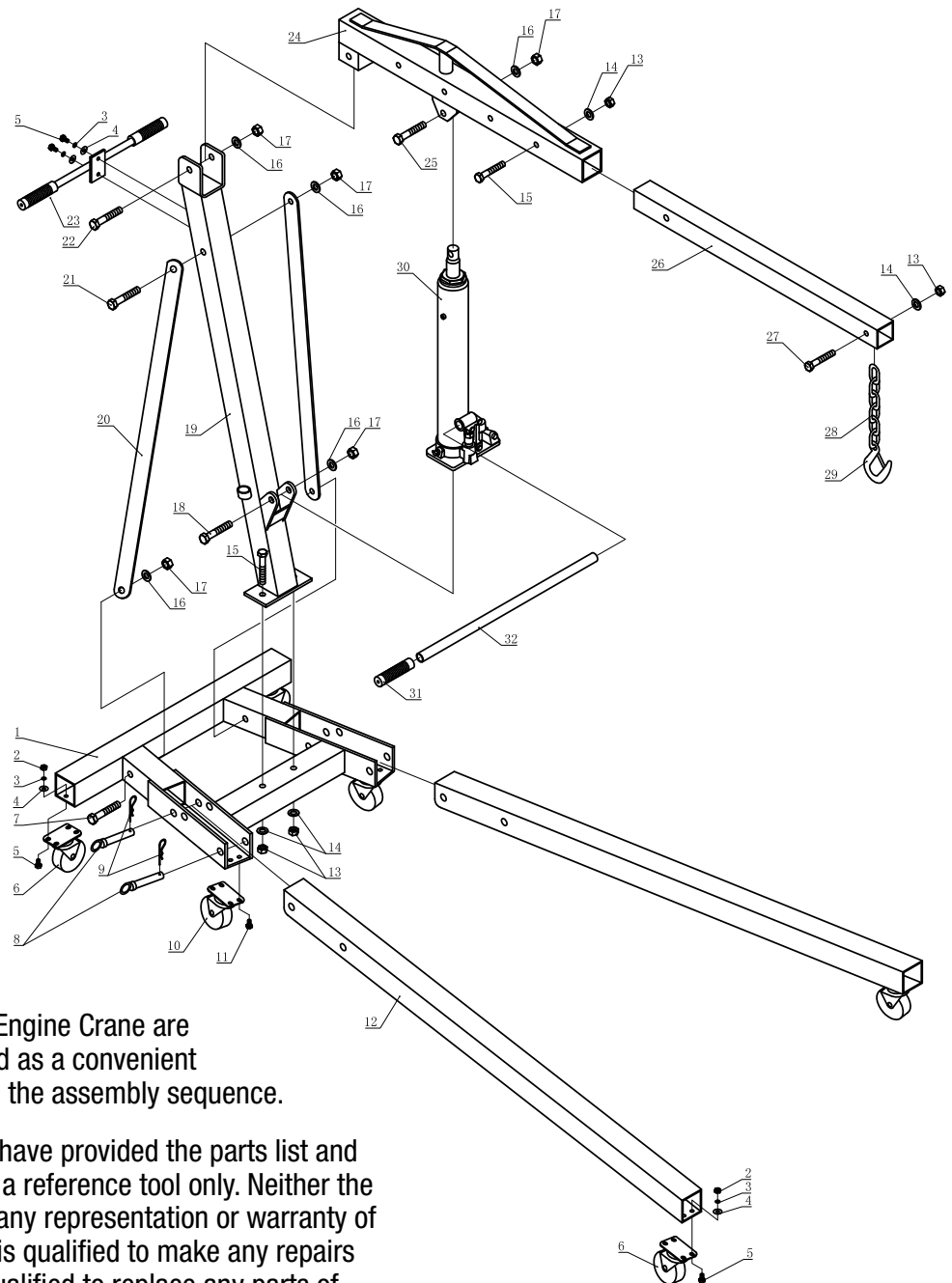

NOTE: Not all components of the Engine Crane are replacement items, but are illustrated as a convenient reference for location and position in the assembly sequence.

The manufacturer and/or distributor have provided the parts list and assembly diagram in this manual as a reference tool only. Neither the manufacturer nor distributor makes any representation or warranty of any kind to the buyer that he or she is qualified to make any repairs to the product, or that he or she is qualified to replace any parts of the product. In fact, the manufacturer and/or distributor expressly states that all repairs and parts replacements should be undertaken by certified and licensed technicians, and not by the buyer. The buyer assumes all risk and liability arising out of his or her repairs to the original product or replacement parts thereto, or arising out of his or her installation of replacement parts thereto.