

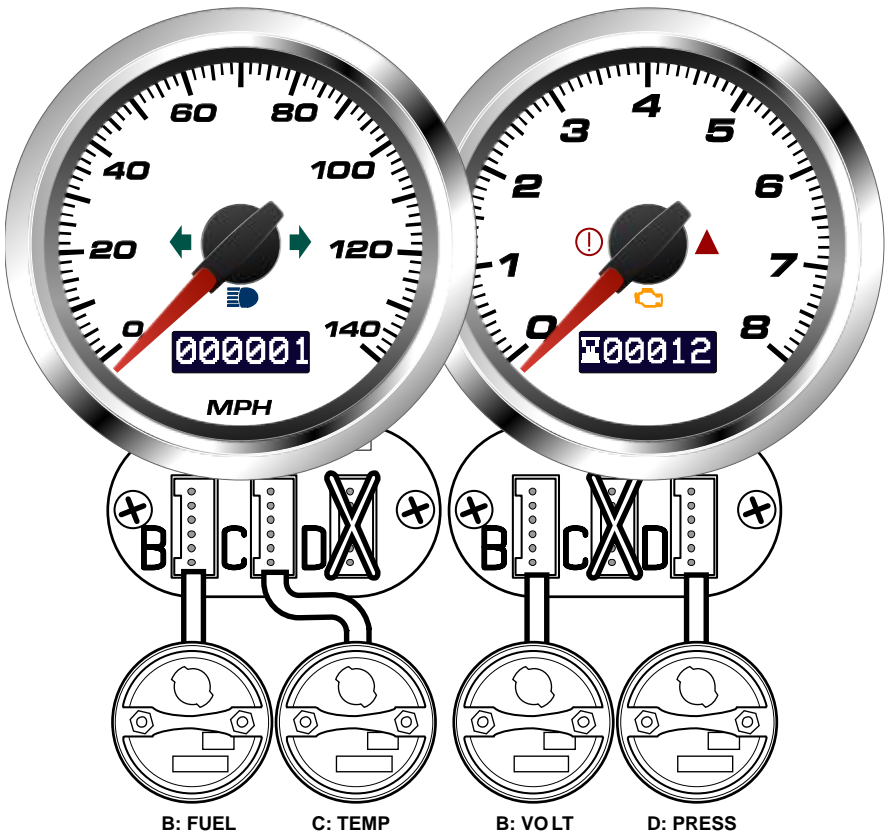

**NEW VINTAGE USA
DETROIT**

PHOENIX BIG BOOK ANALOG AND DIRECT DRIVE KITS



B: FUEL

C: TEMP

B: VOLT

D: PRESS

INTRODUCTION

Thank you for choosing NVU for your build. NVU style features and function will make your ride's dash look and act the part you always wanted it to. NVU instruments are designed, coded, built and programmed right here in the Motor City, Detroit , MI USA. Please take the time to read through this booklet and feel free to contact us with any questions you have before, during and after installation.

TABLE OF CONTEENTS

INTRODUCTION	2
FEATURES	3
SPEEDOMETER SETUP.....	4
SPEEDOMETER SIGNALS AND SENDERS	11
TACHOMETER SIGNALS	12
TACHOMETER SET-UP	13
ANALOG MINOR GAUGE SENDERS AND SIGNALS	17
AUXILLARY INPUTS	18-21
WIRING DIAGRAMS	
THE BACK OF YOUR GAUGE: WITH DATA PORTS	21
6 GAUGE KIT PROG SPEEDO AND TACH	22-23
5 GAUGE KIT PROG SPEEDO	24-25
THE BACK OF YOUR GAUGE: WITHOUT DATA PORTS	26
SPEEDOMETER AND QUAD GAUGE KIT	27
SPEEDO/TACH COMBO WITH QUAD GAUGE	28
3-1 GAUGE KIT	29
STANDALONE SPEEDOMETER WITH OLED SCREEN	30
STANDAOLNE TACHOMETER WITH OLED SCREEN	31
STANDALONE SPEEDO/TACH COMBINATION GAUGE	32
DUAL GAUGES	33
DIP SWITCHES AND SETTING RANGES	34
ANALOG INPUT (RESISTANCE) 2-1/16" GAUGES	35
ANALOG INPUT (TRANSDUCER, 0-5v) 2-1/16" GAUGES	36
TROUBLESHOOTING BASICS	37
AIRCORE 2-1/16" INSTRUMENTS (SHORT SWEEP)	38-39



NVU PHOENIX PLATFORM PLUG-AND-PLAY FEATURES

NVU Plug and play instruments are available in kits that have externally driven 2-1/16" gauges. The speedometer and tachometer are the master (driver) gauges and use data ports on the back to run the minor gauges. This simplifies installation and wiring dramatically not only saving time installing, but also prevents the need for troubleshooting loose connections, mis-wiring, etc. This system is analog driven and requires no additional boxes, driver or data inputs to operate.

Features from the standard Phoenix platform instruments are carried over to make installation and use easier with more features than ever. Plug and play system features:

Minor gauge "Plug and Play" – plug it in the master gauge- no more individual wires!

Phoenix features in addition to PNP :

Speedometer:

Odometer

Trip Odometer

Service mileage

Performance timers with 0-60, 1/8 and 1/4 mile functions

User settable (one time only in the 1st 100 miles) odometer mileage

Voltmeter display

One auxiliary input

Peak speed

MPH/Km/h toggle

Overspeed warning

Easy set-up menus

Digital filtering

GPS ready

Deadfronted (invisible when off) turn signals and hi beam indicators

Tachometer:

Sequential shift alert

Hourmeter

Service hours

Up to 2 additional auxiliary inputs

Peak RPM

Digital filtering

1,2,4,6,8,10,12 cylinder settings (custom options/ranges available)

Signal sources include, GM PCM, Coil, CDI box or other pulsed output

Deadfronted (invisible when off) warning indicators

PHOENIX SPEEDOMETERS

NVU Phoenix platform speedometers offer features found in complete clusters, OE instrument systems and data loggers, all in a standalone unit. While all of the features listed in this manual are available, they are not all required to be used. You can use your speedometer simply as a way to monitor your speed or as a performance meter, its up to you. Some of the advanced features of the ---

- Phoenix platform speedometers:
- OLED high resolution display
- Drive-a mile self calibration
- Integration with OE and aftermarket speed signal and PCM outputs
- GPS input compatible
- Overspeed warning display (AMP Plug and commercial models)
- MPH/KPH speed toggle
- Performance meter 0-60, 1/8 and ¼ mile times/speed capture

Connections:

Speedometers are offered in either a studded or AMP plug connection. All of the wires on the AMP plug may be used depending on the application, check further in the manual for more details.

Terms when using the booklet:

Scroll: Pressing and releasing of the remote button to move through menu options.

Short push: Briefly holding the remote button and releasing it

Long Push: Holding in the remote button for 1 sec. or until a menu display changes.

With all of the features packed into NVU Phoenix platform speedometers, we had to divide them up into different menus. Your speedometer has a main "RUN" menu, and a "SETUP" menu. The RUN menu utilizes the features used during normal operation. The SETUP menu stores all of the items that are set-up during the installation process. (Items can be changed any time after if desired) and are separate to prevent inadvertently changing them during normal use.

During installation please contact NVU for questions/concerns, our qualified tech staff can help get you going.



AUTOCAL (DRIVE A MILE SELF-CALIBRATION) QUICK SET-UP

Check that your digital input filter is set to the proper input setting (see more later in manual if needed) all NVU speedometers are shipped with the input set on HIGH (suitable for most applications) with 16,000 PPM

Enter the setup menu by holding in the remote button and turning on the key (start vehicle)



Scroll to auto calibrate (3RD ITEM)



Hold button until screen displays ready to drive? YES

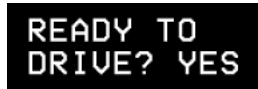

Hold in button until display shows counting 0



Drive exactly one mile(or KM), speed does not affect accuracy. You may or may not see action on the speedometer before or during calibration. **Display will start counting with the digits below increasing.** This is the speedometer counting the number of pulses it is receiving from the signal source. If the display does not count, check your signal source or input filter, the speedometer is not reading a signal



At the end of the mile (or KM) (vehicle can be moving or stationary) Hold the button in until SET YES appears

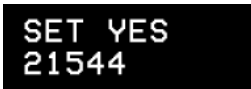

If **NO PULSES is displayed**, a signal was not read by the speedometer. Check your input filter selection and speed signal. See page 37 for signal troubleshooting. See page 11 for signal types. See page 9 for filter settings.

Hold in button until SAVED! Appears



The speedometer is now calibrated. Pressing the button will take you through the rest of the setup menu features. To resume normal operation turn off the key (vehicle) and restart.

INSTALLATION BASICS:

- Use a minimum of 20 gauge insulated, stranded wire, all connections should be connected with a crimp connection or solder and heat shrink.
 - Keep speed signal wire(s) away from potential “noise” sources like ignition wires, tach signal wires, fan motors, pumps etc.
 - Studded speedometers use #8 studs, use applicable eye terminals for wiring.
 - Use a maximum of 5A fuse for the entire cluster, this is usually already in your fuse block
- Commonize wiring, ground power and lights can be common on all gauges and “daisy chained”

SPEEDOMETER OPERATION MENUS

With all of the features packed into NVU Phoenix platform Speedometers, we have divided them into different menus. Your speedometer has a main “RUN” Menu, and a “SETUP” menu. The RUN menu utilizes the features used during normal operation. The SETUP menu stores all of the items that are setup during the installation process. Items can be changed any time after, if desired, and are separate to prevent inadvertently changing them during normal use.

RUN Menu Functions

Features can be accessed in the run menu during normal operation with the key on. To scroll to the various displays in the OLED screen, use a short push or tap of the remote button.

MAIN ODOMETER: Displays total distance travelled in miles or kilometers depending on the model. This display does not show tenths.



A black rectangular display showing the number 000071 in white, seven-segment font.

TRIP METER: Displays current trip distance. Press and hold the button and the odometer will reset to 0. This display will show tenths and will not have any zeros in front of the distance travelled.



A black rectangular display showing the letter T on the left and the number 71.4 on the right, both in white, seven-segment font.

RUN MENU-CONTINUED

Service – This is used to see when your next service interval is due (Oil Change, Tire Rotation...) The interval is set in the SETUP MENU in the next section. This screen is to display the interval remaining.



SERVICE
003000

When the service interval has been reached, the SERVICE REQUIRED warning will display at vehicle startup. The interval can be reset in the SETUP menu.



SERVICE
REQUIRED

MPH : This will display your current Miles per Hour you are traveling



122 MPH

KPH: This will display the current Kilometers per Hour you are traveling



100 KPH

Peak SPEED: This will display the highest speed achieved since last reset Press and hold the button and the odometer will reset to 0.



100 PEAK
MPH

Performance Timers- (where applicable) Displays 1/4 and 1/8 mile time and trap speed as well as 0-60 time. Enter the performance mode you wish to measure, Hold the button until the dialog to start is displayed, enter yes to start or no to reset. Start driving. (Professional driver only on a closed course)
Note: this feature is available on select models only, check product features documentation

SETUP MENU

The setup menu contains menus used for functions not used during normal operation. These features are in this sub-menu to avoid inadvertently changing them during normal operation.

While the vehicle is off press and hold the button. Turn the vehicle on. The odometer will display "SETUP MENU" Short pushes on the button will scroll through these, long hold of the button will select the item. . To exit the SETUP menu turn off the vehicle and restart. You may operate the speedometer in setup mode if required the speedometer will operate to make fine tuning easier.



SERVICE RESET (Push and hold button to enter) This is used to reset service interval if you have saved any (Oil Changes, Tire Rotations, Tune Ups...) You can Set service intervals later in this menu (Service Set section).

Short push to scroll, long push to select



MANUAL CALIBRATE: (Push and hold button to enter) Manual calibration of the speedometer is used to manually enter the pulse setting. You must know the pulse setting of the speed signal to use this feature. Common uses are on OE (pre-configured) senders, GM PCMs GPS senders. Note: using this method will usually get you close enough and fine tuning or auto calibration may be required. Although many speed senders are standard output, various gear ratios and tire sizes will change the pulse settings depending on the vehicle build. The speedometer will accept between 2,000-250,000 PPM. See next page for a chart with common pulse settings.



To enter the manual calibration mode, hold the button until the current pulse setting is shown. NVU ships all speedometer with a 16,000 PPM setting. If the number shown is not 16,000 the speedometer has already been auto-calibrated by the end user. If the pulse count shows zero, the previous autocal attempts resulted in not receiving a speed signal, check you sender and input filter.

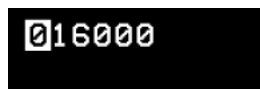

Continued, next page:

MANUAL CALIBRATE, CONTINUED:

The current pulses will be shown, with the first number highlighted. To change that number short push scrolling will increase the digit. Stop on the number required and hold the button to select the next number and follow the same sequence until all numbers are correct and your are on the last digit to the right



The final dialog box will display asking to set. Select Y to accept, N to cancel. Hold the button on Y and the setting will be saved. The speedometer is now manually calibrated.



AUTO CALIBRATE

This feature allows the speedometer to automatically calibrate the speedometer by driving a measured mile (or kilometer). See quick setup earlier in this manual for instructions.

INPUT FILTER:

The digital filter in the speedometer is used to properly read the signal from virtually any pulsed source. Enter the filter by holding the button. Scroll to the filter selection desired, refer to the chart below. Select L, M or H (Low, Medium, High). Hold the button to select FILTER, set yes or no, hold to select, saved! Will display to indicate a successful session. You can change this at any time to adjust as needed or to experiment for the best results for your application.



SOURCE	TYPICAL PPM	SIGNAL TYPE	INPUT FILTER SET
GM PCM (ALL)	4,000	5-12V HALL EFFECT	5V=M, 12V=H
AFTERMARKET 3 WIRE	16,000	12V HALL EFFECT	H
AFTERMARKET 2 WIRE	8,000 OR 16,000	AC SINEWAVE	L
OE 2 WIRE (GM)	40,000	AC SINEWAVE	L
NV4500	108,000	AC SINEWAVE	L
TREMEC	16,000 OR 40,000	LOW AC SINEWAVE	L
GPS SENDER	8,000 OR 16,000	VARIES	5V=M, 12V=H

SETUP MENU, CONTINUED

OVERSPEED Available on AMP-Plug and commercial Units only. The overspeed warning will display and flash an overspeed warning on the OLED display

OVERSPEED!

To set the overspeed enter the setup menu and scroll to overspeed. Hold in the button to enter the menu. The current setting will be displayed:

OVERSPEED  SET SPEED
150 YES

To change the overspeed setting, scroll to YES, then hold the button, the current warning level will be shown with the first digit highlighted. To change the digit, tap the button to increase the number. To move to the next number, hold the button until the next is highlighted. Proceed with the same procedure until all 3 digits are changed. On the last number hold until the display shows the speed and set? YES. The saved speed will be shown. If there is an error you can select NO or turn off the gauge and no changes will be made. To have the warning be inoperable, set the warning level to zero.

150  050  050 SET? YES  050 SAVED!

SET ODOMETER:

The set odometer function is a one-time setting that the end user can change during the first 100 miles of operation. The user can set the mileage to the existing vehicle mileage to maintain a proper vehicle record. Once the mileage passed 100 miles, the feature will no longer be available. To enter the set odometer menu, scroll to set odometer and hold in the button. You will see one time set ? yes. Hold in the button.

SET ODOMETER  ONE TIME SET? YES

000000 will be shown with the first digit highlighted. To change the digit, tap the button to increase the number. To move to the next number, hold the button until the next is highlighted. Proceed with the same procedure until all digits are changed. On the last number hold until the display shows the mileage set YES? Hold in the button and SAVED! Will appear. Turn off and restart the vehicle, mileage is now set.

000000  020500  020500 SET YES?  020500 SAVED!

SPEED SIGNALS AND TYPES OF SPEED SENDERS

Hall Effect speedometer signal sender and sensor (3-wire) Screw on and integrated

Hall effect senders are named as such for the type of signal they produce, a hall effect signal. This sender requires power and ground to operate. The benefit of this sender is it can be accurate at very low speeds as it has a power source. It is generally identified by having 3 connections: Power, ground (sometimes through the body and the signal output).

AC sinewave speed sender (2 wire) screw on and integrated

This type of sender, while more widely used in the 90s and early 2000's is simple and reliable. It generates its own power and sends an AC sinewave signal to the speedometer by teeth spinning past a coil with 2 wires. The sender requires one wire to be grounded and the other is the signal. The wires can be reversed and the same result will work just fine due to the fact that the sender waveform is a simple sinewave. The downside is that due to the sender generating its own power by the speed of the reluctor wheel (teeth) it can often lead to a weak signal at low speeds. This is often seen when a speedometer will not operate until a certain speed, say 25-30 MPH. NVU electronic programmable speedometers have built-in sensitivity settings that can be changed to suit your signal strength. ONLY NVU speedometers have this capability removing the need for converters, boxes or additional equipment. One other disadvantage to this type of sender is the signal cannot be split to send pluses to multiple devices such as speedometer and cruise control.

PCM, ECU, Computer speed signal

Sounds complicated but this actually makes things easier. The speed signal is already being picked up from the source and being sent to the PCM (Powertrain Control Module). The PCM then uses it as it needs and outputs a signal. The most commonly used for builds are PCMs for GM engines. Regardless if its an LS, LT, diesel 4, 6, or 8 cylinder GM PCMs always have 2 outputs (unless flashed by an aftermarket company):

1. The speed signal is a 4,000 PPM output. You will still have to do your drive a mile as the vehicles may have had different gears/tire sizes, but 4000 will get you close.
2. Not related to speed; GM PCMs regardless of engine size or type output a 4 cylinder open collector tachometer signal. This means you need to use a 10-K ohm pull-up resistor and set your tachometer to 4 cylinder.



TACHOMETER SIGNALS AND SET UP

IGNITION COIL Even today the most common ignition source is the traditional coil. incorporates the coil and either points or electronic ignition all into the distributor. Use the negative side of the coil when using a distributor style with traditional points or electronic ignition . The signal is a high-voltage pulsed signal.

COIL ON PLUG (COP) Is essentially the same as a traditional coil with the exception of each cylinder having its own individually fired coil. This setup is used in conjunctions with PCMs. If you use the trigger on a COP the tachometer should be set to 1 cylinder (2PPR) operation.

AFTERMARKET HIGH ENERGY IGNITION SYSTEM

Aftermarket distributors “MSD” boxes, CDI, etc. **ALWAYS HAVE TACH OUTPUT DO NOT CONNECT TO THE COIL OR DAMAGE WILL RESULT.** These types of systems have multiple high energy signals going to the coil and will produce overvoltage feedback damaging to the tachometer, this is why there is a separate tach signal

GM PCM have an open collector signal tach output, consult your PCM documentation for exact pin. You will need a 10K-ohm pullup resistor to change the open collector signal to a square wave (see diagram). This is installed to pull up the signal between the power and tach signal from the PCM. All GM PCMs output a 4 cylinder signal regardless of number of cylinders or if it is gas or diesel.

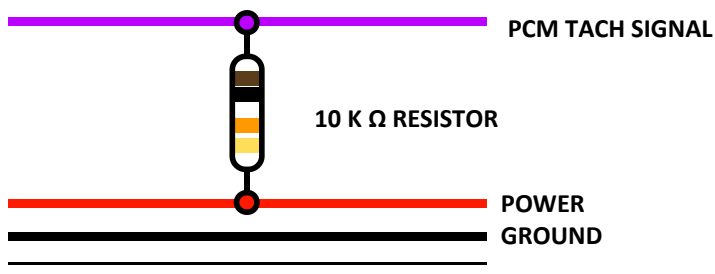

DIESEL APPLICATIONS MAY REQUIRE DIESE TACH WITH LOW INPUT PICKUP

CRANK TRIGGER type generates an AC sinewave signal by using a magnetic sender to “count” the number of teeth. Your NVU tachometer may require bypassing of the internal filter call for more information. You will also need to calibrate the PPR (programmable models with OLED) (pulse per revolution) to the number of teeth or magnets on the flywheel

ALTERNATOR “W” TERMINAL also outputs an AC sinewave like the above crank trigger, a reference tachometer is the best way to determine the exact RPM, then the tach can be properly calibrated by setting the PPR (programmable models with OLED)

INSTALLATION BASICS:

- Use a minimum of 20 gauge insulated, stranded wire, all connections should be connected with a crimp connection or solder and heat shrink.
 - Keep speed signal wire(s) away from potential “noise” sources like ignition wires, tach signal wires, fan motors, pumps etc.
 - Studded speedometers use #8 studs, use applicable eye terminals for wiring.
 - Use a maximum of 5A fuse for the entire cluster, this is usually already in your fuse block
- Commonize wiring, ground, power and lights can be common on all gauges and “daisy chained”

OLED DISPLAY TACHOMETERS WITH ANALOG POINTERS

With all of the features packed into NVU Phoenix platform tachometers, we have divided them into different menus. Your tach has a main “RUN” Menu, and a “SETUP” menu. The RUN menu utilizes the features used during normal operation. The SETUP menu stores all of the items that are setup during the installation process. Items can be changed any time after, if desired, and are separate to prevent inadvertently changing them during normal use.

RUN Menu Functions

Features can be accessed in the run menu during normal operation with the key on. To scroll to the various displays in the OLED screen, use a short push or tap of the remote button.

BLANK SCREEN: We have included a blank screen option to give the user an opportunity to not display any information.

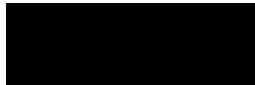

HOURMETER: Displays the total hours the vehicle has been running. This is not resettable. This function is useful to track servicing the vehicle especially when idling for long periods is common such as in commercial, fleet and emergency vehicles, or when a speedometer or odometer is not used in the vehicle.



RUN MENU-CONTINUED

SERVICE HOURS: User resettable hourmeter to track engine use similar to a trip odometer. It is identified by the SH on the left side of the screen



This can be reset just like a trip odometer, while in this screen hold down the set button until zero is displayed. The hours will count up from there. This can be reset at any time and can also be used for tracking time to a destination as well as servicing the vehicle.

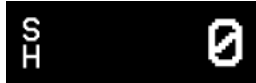

PEAK RPM is displayed on the following screen. This will store and allow the user to view the peak RPM achieved since the last reset.



This can be reset any time by holding in the programming button until all zeros are displayed. This may be reset at any time and the last peak RPM will be stored until reset.



BOOT or SETUP MENU. This area of the tachometer is used during set-up and any of the settings can be changed at any time. The items in the setup menu are “hidden” in this sub-menu to avoid inadvertently changing settings during normal use. To enter the setup menu, hold in the button while turning on the key (you do not have to start the vehicle if you do not want to). The setup menu screen will be displayed. To exit the setup menu, turn the key off, and restart normally.



BOOT MENU, CONTINUED

SET CYLINDERS Allows the user to set the tachometer to accommodate different number of cylinders for their vehicle. See notes on connecting to GM PCMs for later in this manual if required. Tachometers ship from the factory pre-set for 8 cylinders, all set up for 4 stroke engines. Custom ranges and inputs are available for diesel and 2-stroke engines.

SET CYLINDERS

To set the number of cylinders, hold in the button until the current setting is displayed. Scroll to the desired setting and hold until the confirmation message is visible. Select yes or no, and hold in the button until the setting is saved.



INPUT FILTER. Generally this setting does not require any adjustment. You may change the settings if you are having difficulty with noise in your signal or sharp spikes. To enter the filter mode, hold in the button until the settings are shown. There are 3 options low “L” medium “M” and high “H”. You can experiment to see if the filters aid your signal. The changes can be made with the vehicle running so you can see the difference in settings.

To change the setting, scroll to L, M or H and hold in the button. Once you are at the desired setting, hold in the button until the confirmation message is displayed, and select Yes or NO, hold in the button to select. SAVED! will confirm the setting has been changed and now the filter is set.



SHIFT ALERT. The shift alert is built-into the OLED display and will give the driver a warning of when to shift based on RPM. The alert is a 3 stage display, warning 1,000 and 500 RPM before the shift point, and the actual shift point. This can be used to pre-set shift points for optimal horsepower, mileage or to prevent over-revving the engine, it is up to the driver to decide how they would like it to be set up. The shift alert can also be disabled by setting to zero RPM.

BOOT MENU, CONTINUED

SHIFT ALERT, CONTINUED. To enter the shift alert menu, hold in the button while at the screen.

The current shift point will be displayed (0000 for no shift alert). Tap the button to change the first digit which will be highlighted. Each tap will advance the digit by one number.

Hold the button in to advance to the next digit and follow the same sequence until you have the desired setting.

At the last digit, once satisfied, hold in the button to enter the verification menu. Select YES or NO and hold in the button. Once saved, the display will show the current shift setting and SAVED!



HOW THE SHIFT ALERT DISPLAYS INFORMATION: This is active all of the time when in any menu window during normal operation. For the setting above, 5,500 RPM, the display will indicate the engine is 1,000 RPM before the shift point with a single arrow on the screen:



500 RPM before the shift point 2 arrows will be displayed:



At the desired, set shift point, the screen will invert creating a highly visible sign that the engine is at the RPM designated to shift, the word SHIFT will display:

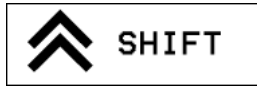

The arrows will operate in the inverse as RPM decreases. The shift point setting can be changed at any time desired, or disabled by setting the shift alert to all zeros (0000).

PROGRAM VERSION. This displays the current software version installed in the unit.

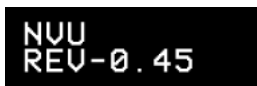

ANALOG MINOR GAUGE SENDERS AND SIGNALS

Senders are the part of the gauge system that send a signal to the gauge to be read, and then displayed on the dial face. There are 4 types of senders, resistance bases pressure, temperature and level (fuel), voltage input pressure transducers, and pulsed speed inputs.

TEMPERATURE SENDERS Signal type is resistance to ground. Resistance DECREASES as temperature rises. All NVU Phoenix temperature gauges use a High-Match temperature sender. The sender will read between 450-500 ohms at room temperature. Both low and high read gauges use the same sender.

PRESSURE SENDERS are resistance to ground signal. All NVU pressure senders are 240-33 ohm, 0-100 PSI regardless of the pressure range.

PRESSURE TRANSDUCERS Send a voltage signal to the gauge to be read and are not senders.. Typically a linear .5V-4.5V signal can be read by any transducer gauge. There are typically 3 wires to the transducer, signal, ground and 5V power (from the gauge or module). There are some 12V transducers on the market. These are powered by 12V but still send out a .5-4.5 V range. The 12V style should be powered by vehicle voltage. 5V transducers require 5V power (from the gauge itself) and connecting to 12V will damage the unit

FUEL LEVEL SENDERS are also resistance to ground. A float arm rotates on a rheostat in the fuel tank and changes the resistance as the float arm moves. This is also available in a tube type sender. The ranges can be various depending on the OE manufacturer. You ALWAYS need to match the fuel gauge to the sender. NVU offers a universal fit 240-33 ohm and 0-90 ohm unit for aftermarket applications. The senders are universal and mount from the top of the tank and have a universal 5-hole flange. These are not intended to replace the stock sender for the tank which was specially manufactured for that tank size/shape/orientation. Use a stock sender if at all possible to make things easier on yourself. Please see DIP switch settings in this booklet (PAGE 34) for a full listing of stock ranges.

AUXILLARY INPUTS

Phoenix platform instruments feature add-on functions that can be displayed directly on the OLED screen as needed. This can be accomplished by adding an NVU pressure or temperature sender. Custom options are available, feel free to contact us for your needs.

How it works:

Every speedometer (standalone and 3-1) has one auxiliary input wire on the harness. Please see the wiring diagram for that particular unit/kit configuration.

Every Tachometer (standalone and 3-1) and speedo/tach combo gauge has 2 auxiliary inputs. Each is on the AMP plug. Please see the wiring diagram for that particular unit/kit configuration.

All 3 inputs have the same features and menu settings. There are 3 types of inputs standard and all are resistance to ground.

1. TEMPERATURE. All standard auxiliary inputs for temperature run from a standard NVU hi-match temperature sender part number 99320-04. You must use this sender to monitor any temp readings. This sender is separate from any other sender you are using to monitor any other setting on the gauge itself. (You cannot “split” a sender signal.). Custom ranges are available at additional cost-contact us for more details.

2. PRESSURE All standard axillary inputs for pressure operate from a standard NVU pressure sender 0-100 PSI, 240-33 ohm part number 90100-04. This range works well for anything that uses at least 40% of the scale. (no less than 40 PSI). If you need a different range, custom inputs are available, call us for more details.

Sender grounds: The above sender operate by varying the resistance to ground through the base of the sender (threads). If you are monitoring the temperature or pressure by attaching to a non-metal surface (plastic, rubber or insulated line) You will require a floating ground sender. This has an additional terminal for grounding the unit.

3. SHIFTER NVU shift inputs operate on resistance to ground. Please see part number 99440-04 shift input terminal for exact specifications for shift inputs. This terminal box accepts ground signals from various manufacturer’s shift drivers and converts the signal to be compatible with any NVU Phoenix instrument with an OLED display.

SETTING UP THE AUXILLARY INPUTS

Install sender as needed, run wire (20 ga min) to the appropriate input wire. To set up the functions using the OLED display screen, the vehicle does not need to be running.

Enter the SETUP menu by holding in the programming button while turning on the key.



Scroll to AUX INPUT SETUP or AUX 2 SETUP









Speedometers use AUX Input (Green wire) ONLY

Tachometers and speedo/tachs use AUX INPUT (Green/yellow) and AUX 2 (Yellow wire)

Customs and specialty instruments please check your wiring diagram.

Once you have entered the specified input setting, scroll to the desired reading you would like to display on the OLED screen.

AUX INPUT SELECTION	AUX 2 INPUT SELECTION	DISPLAY ON OLED SCREEN	SENDER USED
AUX INPUT NOT USED	AUX 2 NOT USED	NOT VISIBLE	
AUX INPUT OIL TEMP	AUX 2 OIL TEMP	 168 °F	TEMPERATURE 99320-04
AUX INPUT TRANS TEMP	AUX 2 TRANS TEMP	 167 °F	TEMPERATURE 99320-04
AUX INPUT WTR TEMP	AUX 2 WTR TEMP	 168 °F	TEMPERATURE 99320-04
AUX INPUT OIL PRESS	AUX 2 OIL PRESS	 45 PSI	PRESSURE 99100-04
AUX INPUT FUEL PRESS	AUX 2 FUEL PRESS	 45 PSI	PRESSURE 99100-04
AUX INPUT BOOST	AUX 2 BOOST	 46	PRESSURE 99100-04
AUX INPUT SHIFTER	AUX 2 SHIFTER	 □	SHIFT DRIVER

AUXILLARY INPUTS CONTINUED

Once you are on the desired function to be displayed, press and hold the programming button until the INPUT SET screen is displayed.



This can be changed at any time, just follow the preceeding setup process. You may now continue on to other programming features or you can restart the instrument. You must turn the power off and nd re-cycle the power before setting will take effect. You do not have to start the vehicle, just simply turn the key off and back on again.

NORMAL OPERATION

The auxiliary inputs are designed to be just that, additional instrument features that you may or may not need to be viewing at all times. To view a particular input while using the instruments, tap the programming button to scroll to the display you would like to view. It will remain visible until the button is depressed again.

MORE INFORMATION

The additional inputs are designed to measure temperature and pressure using NVU (or equivalent) senders. The temperature or pressure of virtually anything can be measured, for example Trans temp is shown on the display with a "T" this can be for anything you like, axles, trans, t-case, its up to you, so keep your mind open when it comes to the vitals you would like to watch.

CUSTOM OPTIONS:

Need something special? Custom range? Custom display? We can do that for you. Just contact a factory rep for more details.

THE BACK OF YOUR GAUGE PROGRAMMABLE WITH OLED SCREEN AND PORTS

All programmable speedometers and tachometers with an OLED screen of any size are master gauges that can drive minor functions. The minor gauges are driven directly by the master and no additional connections are required.

AMP PLUG SOCKET :

USE the NVU universal AMP plug and wire as shown in the proper diagram. NVU uses the same plug for all gauges so some wires may not be used in your application.

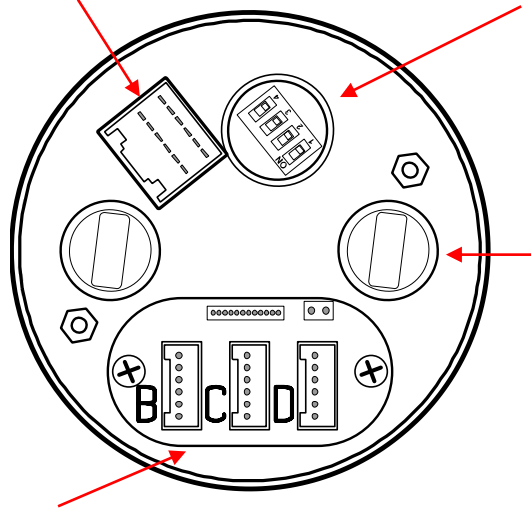

DIP SWITCHES:

Used to adjust fuel range on speedometers. See fuel gauge chart later in this booklet. Remove the black plastic cover to access this if needed. See DIP switch settings later in this booklet

LIGHT SOCKETS:

The sockets hold NVU bright white LED 194 bulbs. They are replaceable if needed. If you need to replace a bulb, the LEDs are polarity sensitive and have to be installed properly to operate. If you find the bulb will not light, turn it 180 degrees and reinstall. LEDs are not dimmable using a standard dimmer. Wire into your parking lamp circuit and use an LED dimmer if required

DRIVER SOCKETS:

This applies to 5 and 6 gauge kits with NVU PNP technology. 2, 3 and 4 gauge kits will not use the driver features. Refer to each wiring diagram. Plug the appropriate gauge into the socket and it will function through the master driver unit.

The B, C and D pins are used to connect the 2-1/16" gauges through the master gauge. All functions and lighting are done through this plug. Refer to the wiring diagram for each kit for proper wiring. Below is each plug's function and its corresponding input wire color. Pins C and D are the same on the speedo and tach.

SPEEDOMETER:

- B: PROGRAMMABLE FUEL (GREEN WIRE)** Connects to your fuel sender. The input is programmable, please see the fuel gauge DIP switch settings on page 34
- C: WATER TEMPERATURE (YELLOW/GREEN WIRE)** Connects to the NVU temperature sender.
- D: OIL PRESSURE (YELLOW WIRE)** Connects to NVU pressure sender .

TACHOMETER:

- B: VOLTS** No input wire required, internal to gauge
- C: WATER TEMPERATURE (YELLOW/GREEN WIRE)** Connects to the NVU temperature sender.
- D: OIL PRESSURE (YELLOW WIRE)** Connects to NVU pressure sender .

6 GAUGE KIT PROGRAMMABLE SPEEDO AND TACHOMETER WITH OLED SCREENS

MASTER GAUGE WIRING

All programmable speedometers and tachometers with an OLED screen of any size are master gauges that can drive minor functions. The minor gauges are driven directly by the master and no additional connections are required. Wire as shown below and plug the minor gauges into their appropriate plug (B,C,D) on the back of the master gauge.

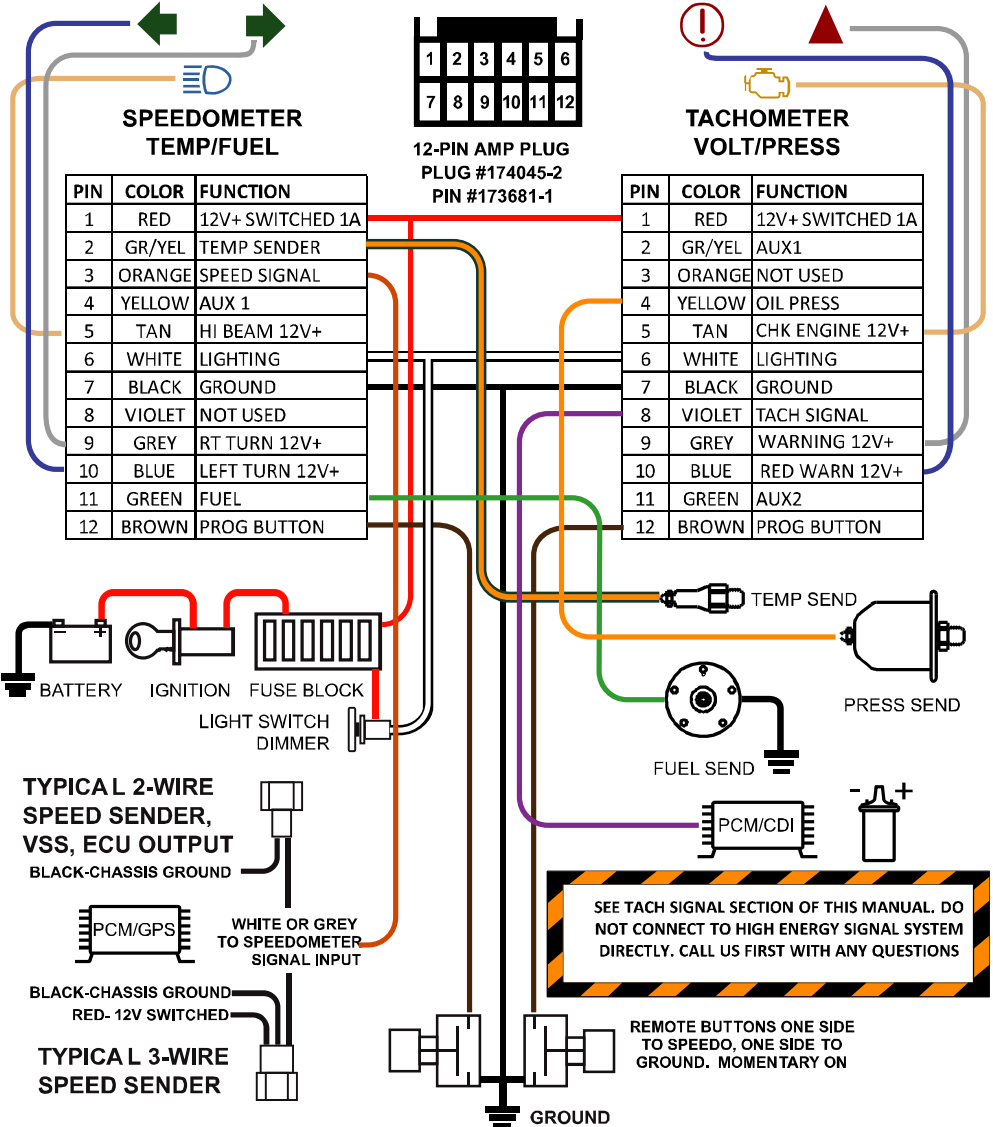

MINOR GAUGE WIRING 6 GAUGE KIT

All programmable speedometers and tachometers with an OLED screen of any size are master gauges that can drive minor functions. The minor gauges are driven directly by the master and no additional connections are required. Wire as shown below and plug the minor gauges into their appropriate plug (B,C,D) on the back of the master gauge.

Follow the diagram below to properly plug the minor gauges into the master units.

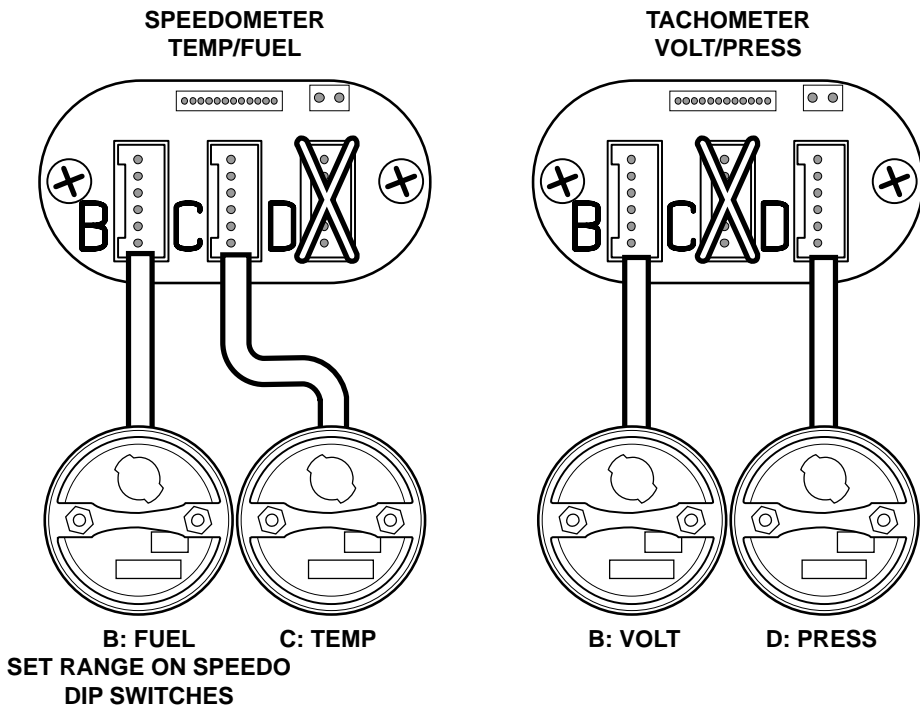

The B, C and D pins are used to connect the 2-1/16" gauges through the master gauge. All functions and lighting are done through this plug. Refer to the wiring diagram for each kit for proper wiring. Below is each plug's function and its corresponding input wire color. Pins C and D are the same on the speedo and tach.

SPEEDOMETER:

- B: PROGRAMMABLE FUEL (GREEN WIRE)** Connects to your fuel sender. The input is programmable, please see the fuel gauge DIP switch settings later on page 34
- C: WATER TEMPERATURE (YELLOW/GREEN WIRE)** Connects to the NVU temperature sender.

TACHOMETER:

- B: VOLTS** No input wire required, internal to gauge
- D: OIL PRESSURE (YELLOW WIRE)** Connects to NVU pressure sender .

5 GAUGE KIT PROGRAMMABLE SPEEDOMETER

MASTER GAUGE WIRING

All programmable speedometers and tachometers with an OLED screen of any size are master gauges that can drive minor functions. The minor gauges are driven directly by the master and no additional connections are required. Wire as shown below and plug the minor gauges into their appropriate plug (B,C,D) on the back of the master gauge.

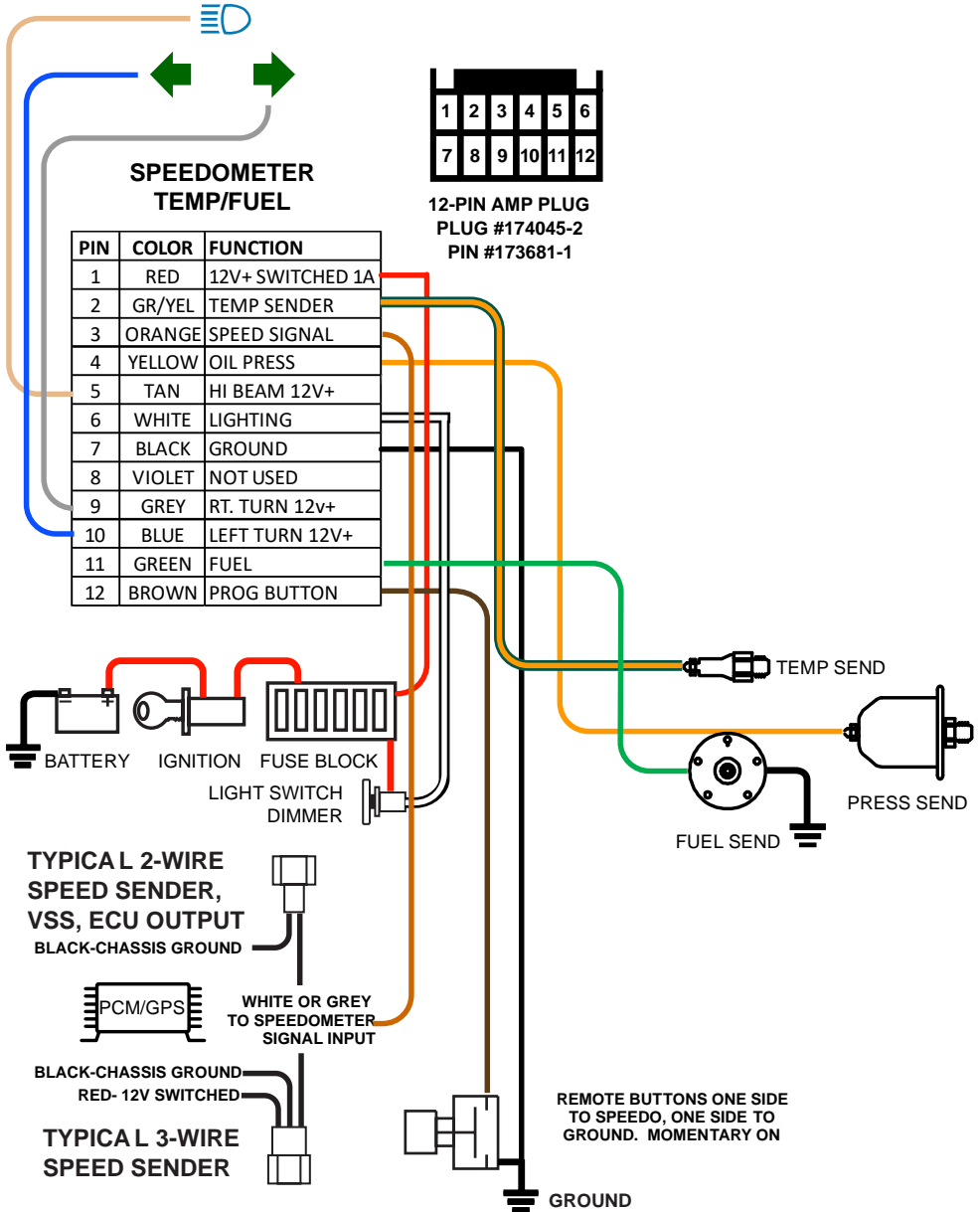

MINOR GAUGE WIRING 5 GAUGE KIT PROGRAMMABLE SPEEDOMETER

All programmable speedometers and tachometers with an OLED screen of any size are master gauges that can drive minor functions. The minor gauges are driven directly by the master and no additional connections are required. Wire as shown below and plug the minor gauges into their appropriate plug (B,C,D) on the back of the master gauge.

Follow the diagram below to properly plug the minor gauges into the master units.

VOLTMETER

The voltmeter is a standalone gauge that runs independently from the master gauge system. The connections can be communized as needed for installation. Voltage is read through the gauge circuitry, so no sender connection is required.

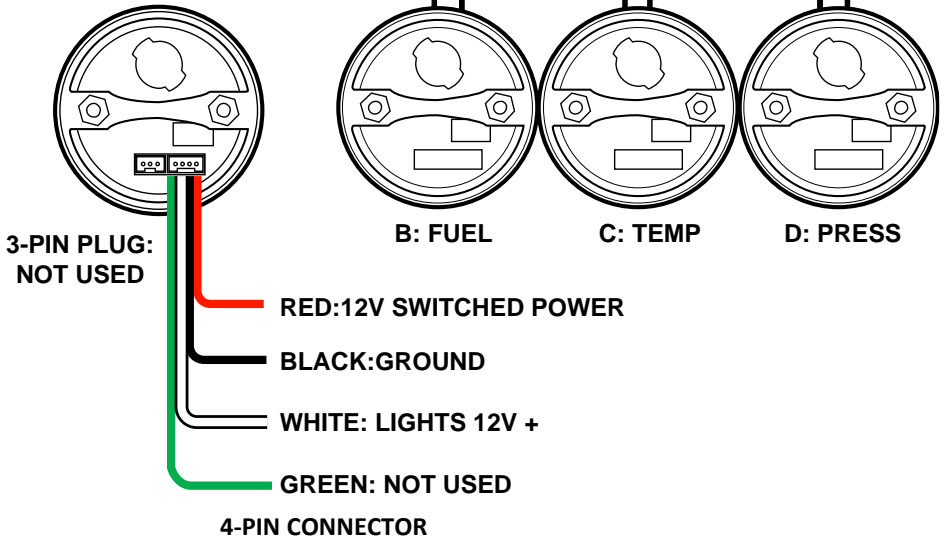

THE BACK OF YOUR GAUGE PROGRAMMABLE WITH OLED SCREEN WITHOUT PORTS

All programmable speedometers and tachometers with an OLED screen of any size are WITHOUT PORTS ON THE BACK Are the same units as with ports except the plugs are not used on this particular model. This is usually in a 2 gauges kit or a standalone order where driven instruments are not used. The programming, setup and features are the same on all models of NVU instruments with an OLED screen.

AMP PLUG SOCKET :

USE the NVU universal AMP plug and wire as shown in the proper diagram. NVU uses the same plug for all gauges so some wires may not be used in your application.

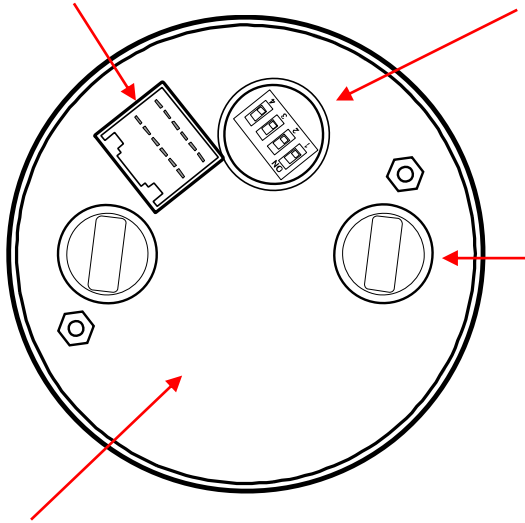

DIP SWITCHES:

Used to adjust fuel range on speedometers with ports, quad gauges, dual gauges and 3-1 gauges. Please use the driven unit with the fuel function to set the switches. See DIP switch settings on page 34.

LIGHT SOCKETS:

The sockets hold NVU bright white LED 194 bulbs. They are replaceable if needed. If you need to replace a bulb, the LEDs are polarity sensitive and have to be installed properly to operate. If you find the bulb will not light, turn it 180 degrees and reinstall. LEDs are not dimmable using a standard dimmer. Wire into your parking lamp circuit and use an LED dimmer if required

NO DRIVER PORTS:

Standalone gauges (speedometers, tachometers, quad gauges and 3-1 sets do not have driver ports. The ports mentioned previously are used on kits with remote 2-1/16" gauges. All features are shared between both models.

STANDALONE GAUGES NOT IN KITS:

If installing a gauge normally in a kit (quad gauge, etc) wire as shown in the diagram, ignoring the other gauge(s) in the kit. All standalone instruments operate on their own independently from one another.

SPEEDOMETER AND QUAD GAUGE KIT

Both the speedometer and quad gauges are standalone units that are internally driven. If your speedometer has data output plugs on the back these are not required for installation. Below is a schematic of how the wiring is typically accomplished.

FUEL GAUGE SET-UP: The quad gauge features a programmable input that can be set any time with the DIP switches on the back. Please see DIP switch setting on page 34.

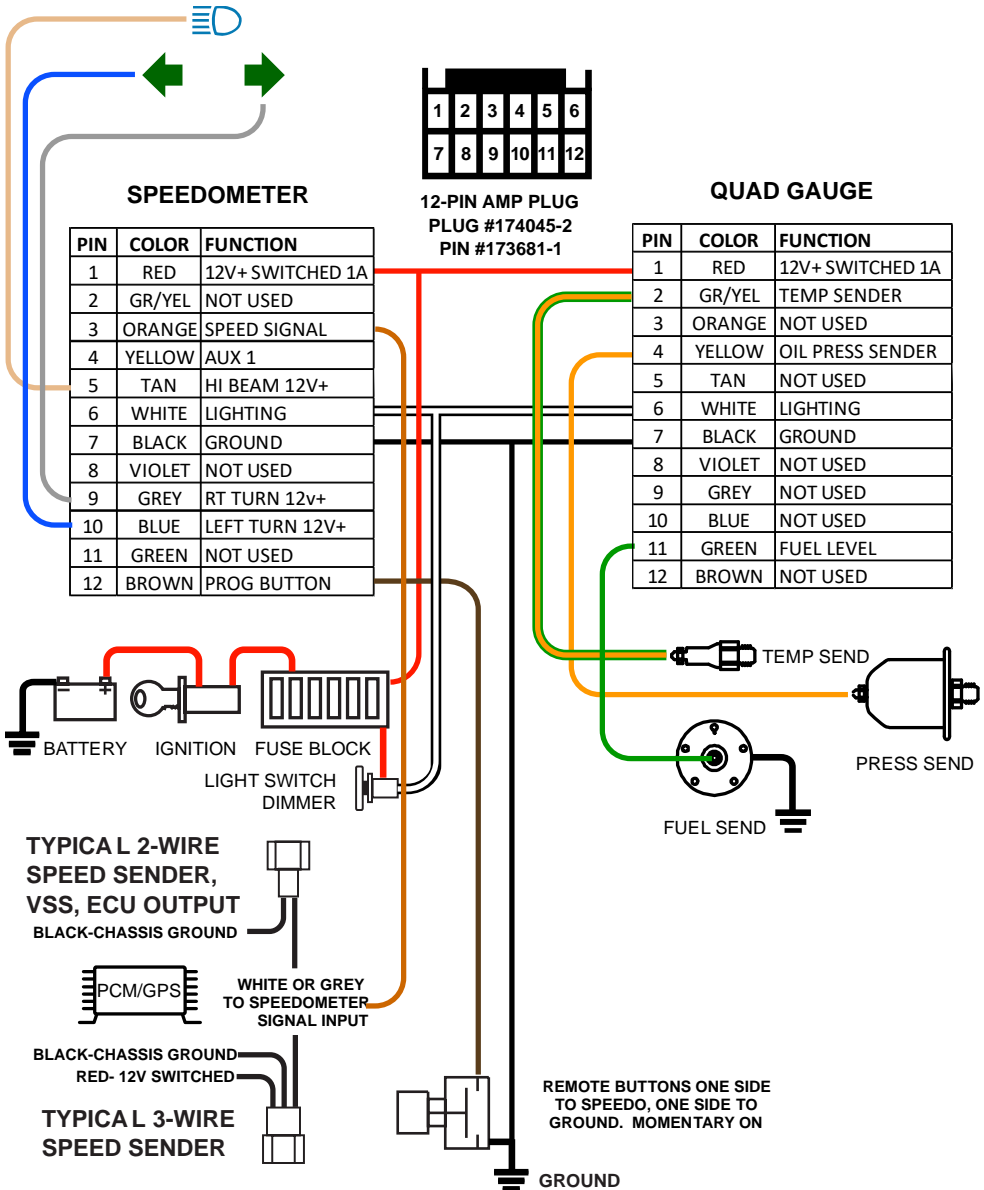

SPEEDOMETER/TACHOMETER COMBINATION AND QUAD GAUGE KIT

Both the speedometer and quad gauges are standalone units that are internally driven. If your speedometer has data output plugs on the back these are not required for installation. Below is a schematic of how the wiring is typically accomplished.

SPEEDO/TACH SETUP: The calibration and setup for the speedo/tach gauge is the same as the speedometers and tachometers only the set-up menus have been combined into one unit.

FUEL GAUGE SET-UP: The quad gauge features a programmable input that can be set any time with the DIP switches on the back. Please see DIP switch setting on page 34.

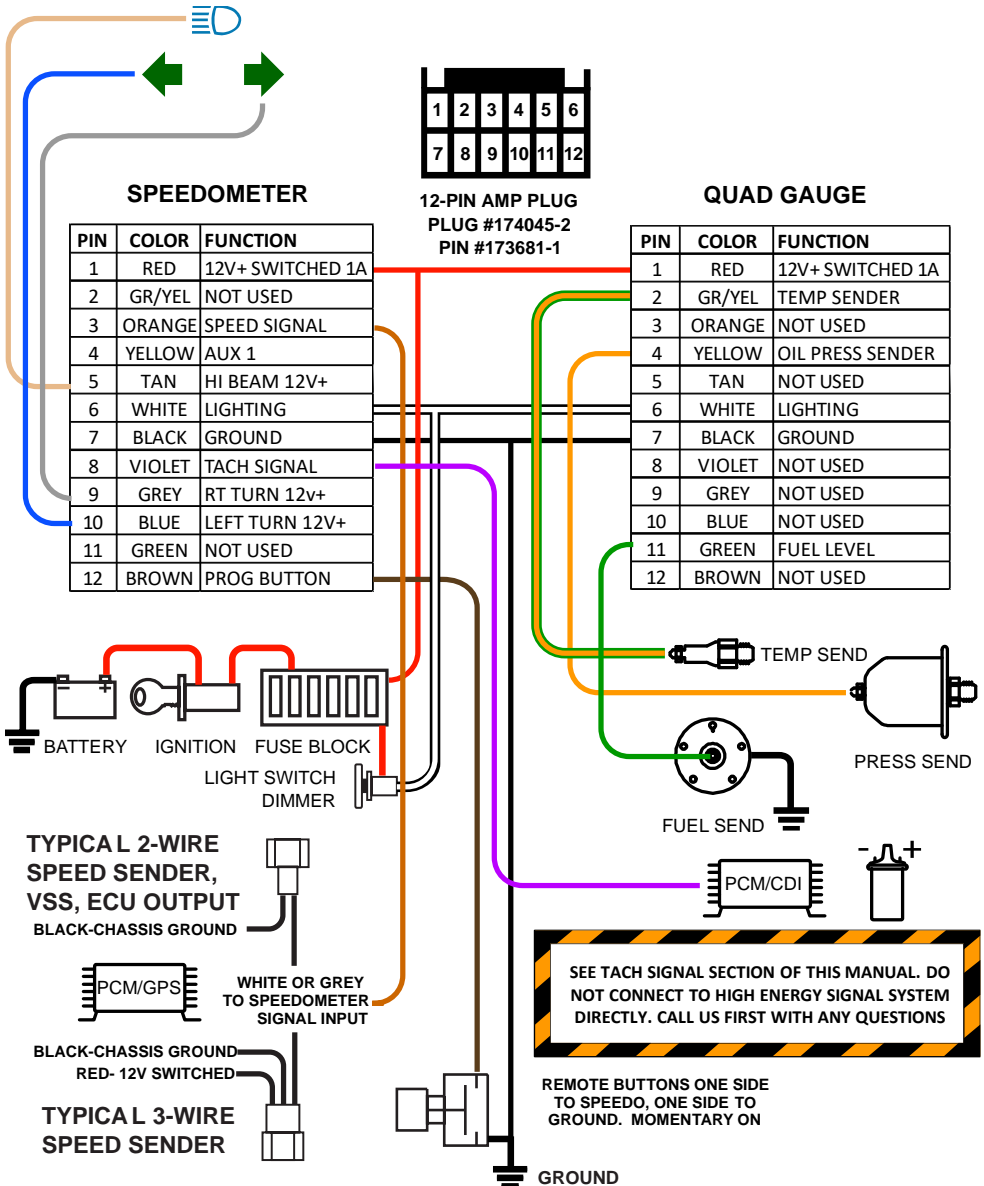

3-1 GAUGE KIT WIRING DIAGRAM

Both the speedometer and quad gauges are standalone units that are internally driven. Below is a typical wiring setup of how the 2 gauges are wired in a set. Indicators are dead fronted (invisible when off) and powered by 12V+.

FUEL GAUGE SET-UP: The Tachometer features a programmable input that can be set any time with the DIP switches on the back. Please see DIP switch setting on page 34

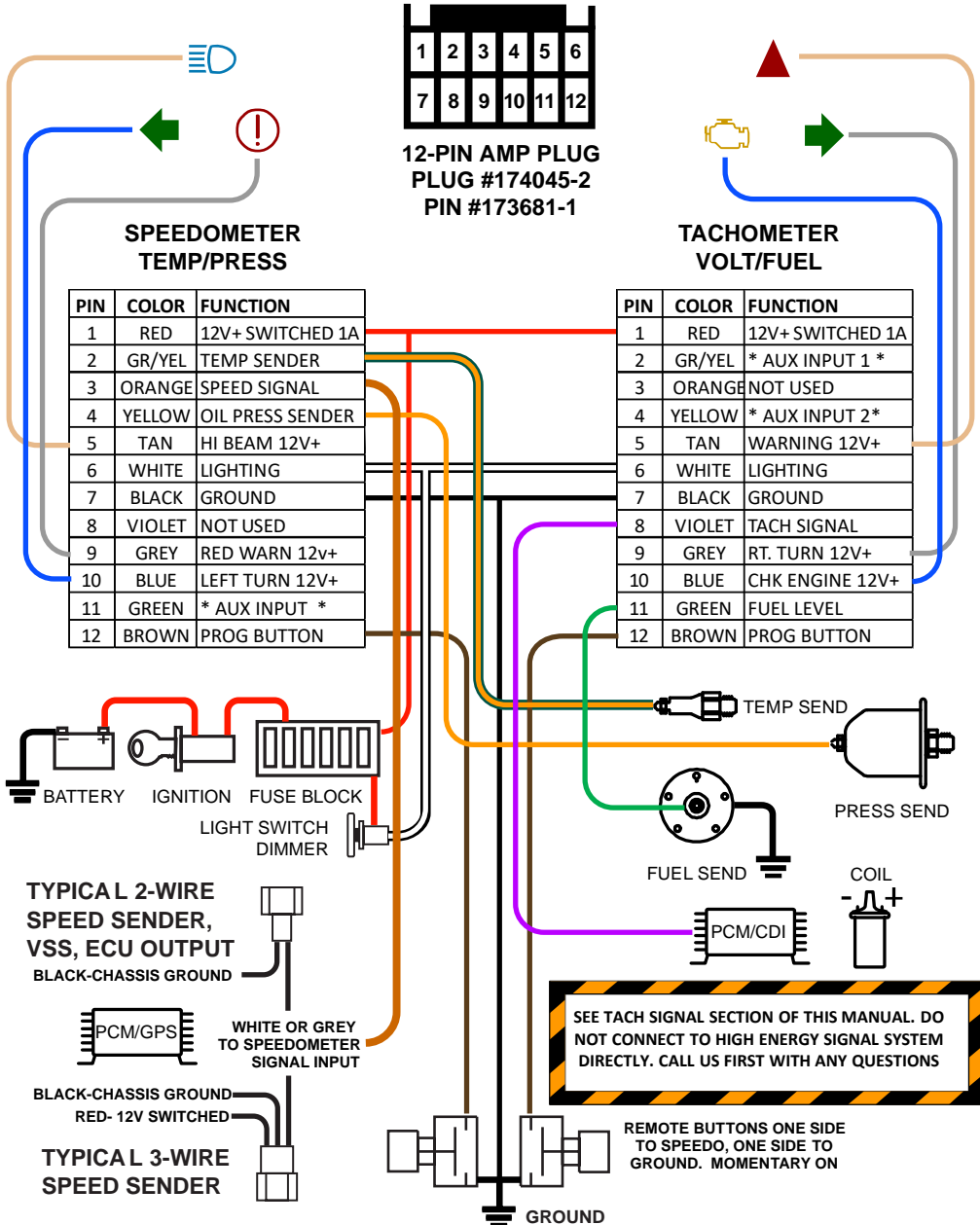

PROGRAMMABLE SPEEDOMETER (STANDALONE)

The speedometer is a standalone unit that is internally driven. If your speedometer has data output plugs on the back these are not required for installation. Below is a schematic of how the wiring is typically accomplished. The indicators are 12V+ powered and deadfronted (invisible when off)

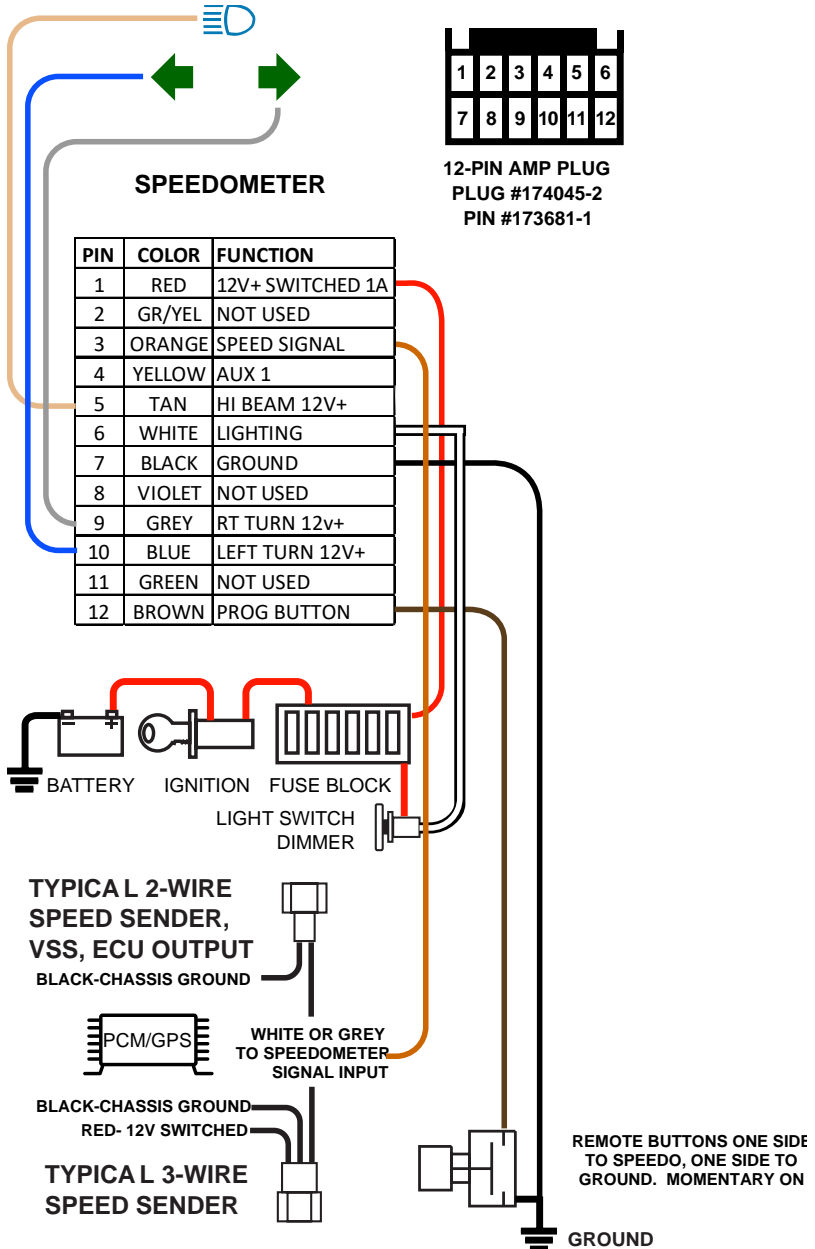

PROGRAMMABLE TACHOMETER WITH OLED SCREEN (STANDALONE)

The tachometer is a standalone unit that is internally driven. If your speedometer has data output plugs on the back these are not required for installation. Below is a schematic of how the wiring is typically accomplished.

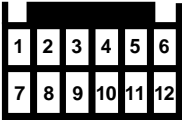

12-PIN AMP PLUG
PLUG #174045-2
PIN #173681-1

PIN	COLOR	FUNCTION
1	RED	12V+ SWITCHED 1A
2	GR/YEL	AUX1
3	ORANGE	NOT USED
4	YELLOW	OIL PRESS
5	TAN	CHK ENGINE 12V+
6	WHITE	LIGHTING
7	BLACK	GROUND
8	VIOLET	TACH SIGNAL
9	GREY	WARN LIGHT 12V+
10	BLUE	WARN LIGHT 12V+
11	GREEN	AUX2
12	BROWN	PROG BUTTON

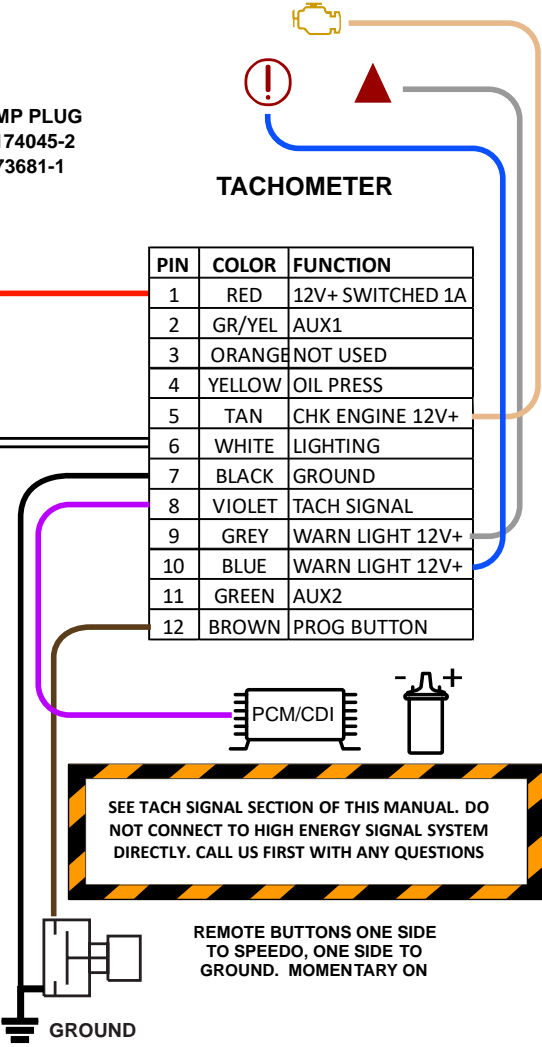
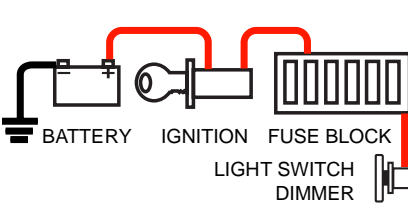

SEE TACH SIGNAL SECTION OF THIS MANUAL. DO NOT CONNECT TO HIGH ENERGY SIGNAL SYSTEM DIRECTLY. CALL US FIRST WITH ANY QUESTIONS

REMOTE BUTTONS ONE SIDE TO SPEEDO, ONE SIDE TO GROUND. MOMENTARY ON

SPEEDOMETER/TACHOMETER COMBINATION

The speedo/tach combination is internally driven and requires no additional plugs or modules to run.. If your speedometer has data output plugs on the back these are not required for installation. Below is a schematic of how the wiring is typically accomplished. **SPEEDO/TACH SETUP:** The calibration and setup for the speedo/tach gauge is the same as the speedometers and tachometers only the set-up menus have been combined into one unit.

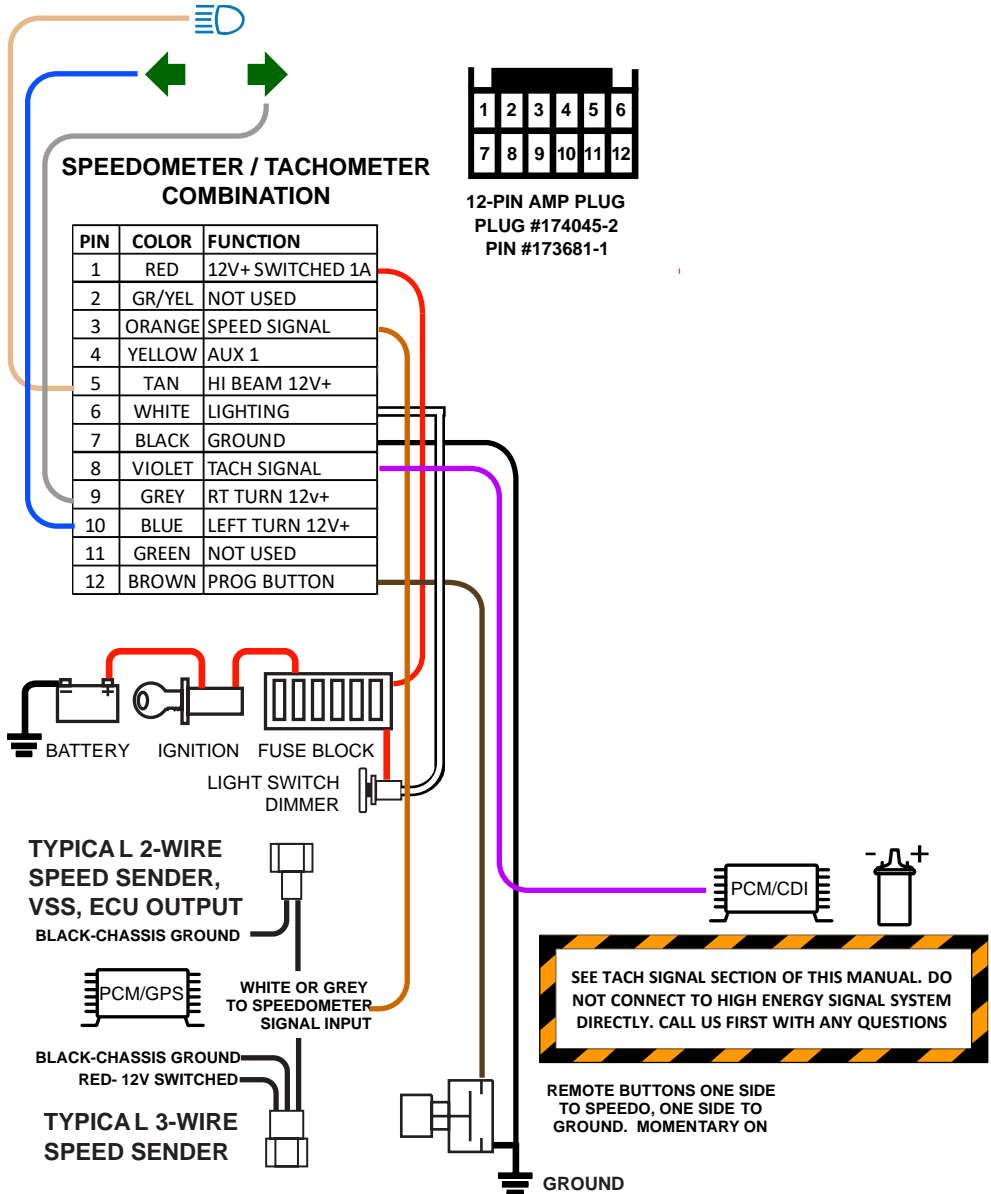

DUAL GAUGE KIT

Each dual gauge is independent of each other and internally driven without the need for additional inputs. Wire as shown below and tie in common items (power, ground, lights) into the speedometer and tachometer if needed.

FUEL GAUGE SET-UP: The temp/fuel gauge features a programmable input that can be set any time with the DIP switches on the back. Please see DIP switch setting on page 34.

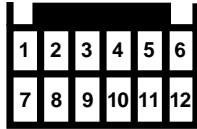

12-PIN AMP PLUG
PLUG #174045-2
PIN #173681-1

DUAL GAUGE TEMP/FUEL

PIN	COLOR	FUNCTION
1	RED	12V+ SWITCHED 1A
2	GR/YEL	TEMP SENDER
3	ORANGE	NOT USED
4	YELLOW	NOT USED
5	TAN	NOT USED
6	WHITE	LIGHTING
7	BLACK	GROUND
8	VIOLET	NOT USED
9	GREY	NOT USED
10	BLUE	NOT USED
11	GREEN	FUEL SIGNAL
12	BROWN	NOT USED

DUAL GAUGE VOLT/PRESSURE

PIN	COLOR	FUNCTION
1	RED	12V+ SWITCHED 1A
2	GR/YEL	NOT USED
3	ORANGE	NOT USED
4	YELLOW	OIL PRESSURE
5	TAN	NOT USED
6	WHITE	LIGHTING
7	BLACK	GROUND
8	VIOLET	NOT USED
9	GREY	NOT USED
10	BLUE	NOT USED
11	GREEN	NOT USED
12	BROWN	NOT USED

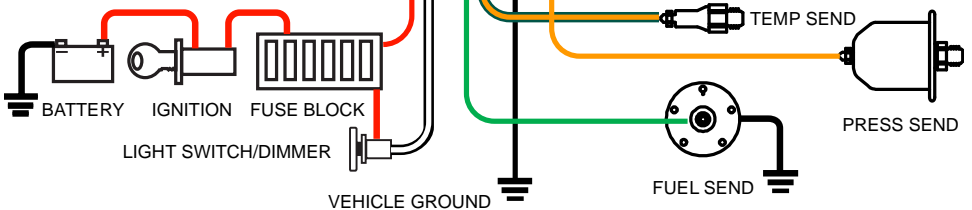

DIP SWITCHES

DIP switches are used on the back of some of the gauges to set ranges for your application. This can be changes at any time but in general They are set at the factory or on-site during installation and are left in that position for the life of the vehicle.

When setting DIP switches, ON should be in the up position.

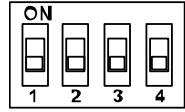

FUEL GAUGE:

All fuel gauges are programmable by the DIP switches on the driver gauge or the 2-1/16" gauge itself. All fuel gauges and ranges are identical on all instruments. Set the switches as shown in the chart below for your application.

SENDER TYPE MAKE/YEAR	RANGE E-F Ω	1	2	3	4
EARLY GM/FORD PRE 65	0-30	OFF	OFF	ON	OFF
GM 65-89	0-90	OFF	ON	OFF	OFF
GM 90S-UP	40-250	OFF	ON	ON	OFF
FORD/AMC/MOPAR 65-86	73-10	OFF	OFF	OFF	ON
FORD 87-UP	20-145	ON	ON	OFF	OFF
UNIVERSAL/SW	240-33	ON	OFF	OFF	OFF
CUSTOM/EARLY FORD	168-15	ON	OFF	ON	OFF

2-1/16" ANALOG MINOR GAUGES

This applies to all standalone 2-1/16" gauges. Driven instruments are adjustable at the master gauge on the back under the plug. On the back of the 2-1/16" gauge the switches are visible without removing any covers/plugs.

Analog instruments refer to fuel, temperature, volts and pressure that use a traditional resistance to ground sender (not a transducer). All gauges are set at the factory to match the gauge dial range. The only time the end user will need to change the settings is for the fuel range. Use the settings below as a reference if needed.

ANALOG INPUT	INPUT Ω	1	2	3	4
OIL PRESS 0-100 PSI	240-33	OFF	OFF	OFF	OFF
WATER TEMPERATURE	500-19	OFF	OFF	ON	ON
OIL/TRANS TEMP	500-19	OFF	ON	OFF	ON
VOLTAGE	10-18V	OFF	ON	ON	ON

2-1/16" 0-5V INPUT MINOR GAUGES

This applies to all standalone 2-1/16" gauges with a 0-5 or .5-4.5V input (transducer). The instrument will have BOTH a 4 and a 3 pin plug. The 3 pin plug will power your transducer. Please refer to the chart below for input DIP switch settings required for your application.

VOLTAGE INPUT	INPUT Ω	1	2	3	4
TRANSDUCER	.5-4.5V	ON	OFF	OFF	ON
0-5 INPUT (AFR, OTHER)	0-5V	ON	OFF	ON	ON

ANALOG INPUT MINOR GAUGES

DIP switches are used on the back of some of the gauges to set ranges for your application. This can be changed at any time but in general they are set at the factory or on site during installation and are left in that position for the life of the vehicle. When setting DIP switches, ON should be in the up position.

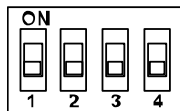

FUEL GAUGE:

All fuel gauges are programmable by the DIP switches on the driver gauge or the 2-1/16" gauge itself. All fuel gauges and ranges are identical on all instruments. Set the switches as shown in the chart below for your application.

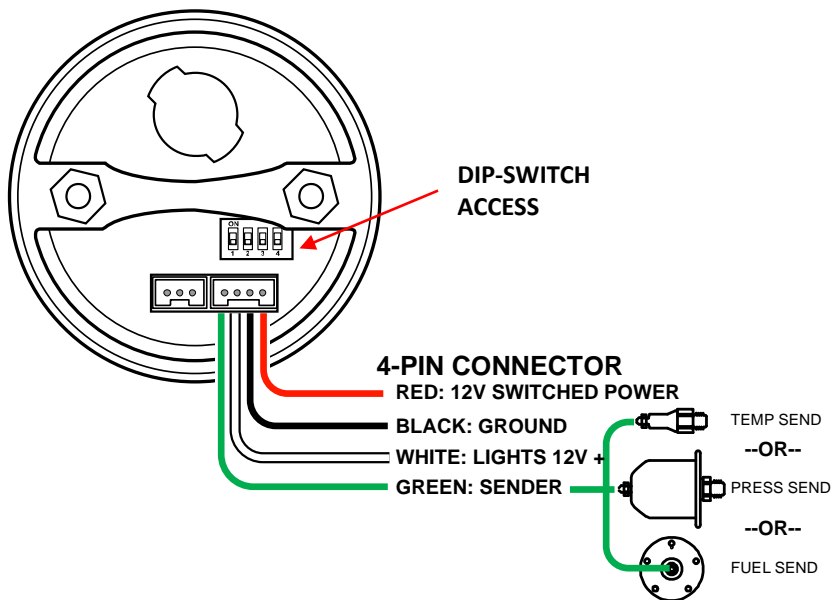

ANALOG INPUT	INPUT Ω	1	2	3	4
OIL PRESS 0-100 PSI	240-33	OFF	OFF	OFF	OFF
WATER TEMPERATURE	500-19	OFF	OFF	ON	ON
OIL/TRANS TEMP	500-19	OFF	ON	OFF	ON
VOLTAGE	10-18V	OFF	ON	ON	ON

SENDER TYPE MAKE/YEAR	RANGE E-F Ω	1	2	3	4
EARLY GM/FORD PRE 65	0-30	OFF	OFF	ON	OFF
GM 65-89	0-90	OFF	ON	OFF	OFF
GM 90S-UP	40-250	OFF	ON	ON	OFF
FORD/AMC/MOPAR 65-86	73-10	OFF	OFF	OFF	ON
FORD 87-UP	20-145	ON	ON	OFF	OFF
UNIVERSAL/SW	240-33	ON	OFF	OFF	OFF
CUSTOM/EARLY FORD	168-15	ON	OFF	ON	OFF

ANALOG INPUT 0-5v OR .5-4.5V INSTRUMENTS

DIP switches are used on the back of some of the gauges to set ranges for your application. This can be changed at any time but in general they are set at the factory or on site during installation and are left in that position for the life of the vehicle. When setting DIP switches, ON should be in the up position.

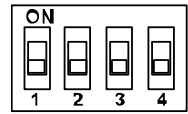

2-1/16" 0-5V INPUT MINOR GAUGES

This applies to all standalone 2-1/16" gauges with a 0-5 or .5-4.5V input (transducer). The instrument will have BOTH a 4 and a 3 pin plug. The 3 pin plug will power your transducer. Please refer to the chart below for input DIP switch settings required for your application.

Transducers operate on .5-4.5V range. AFR and 0-5V output devices use 0-5V. The input for both ranges should be on the BLUE wire on the 3-pin harness. The GREEN wire on the 4-pin harness is not used.

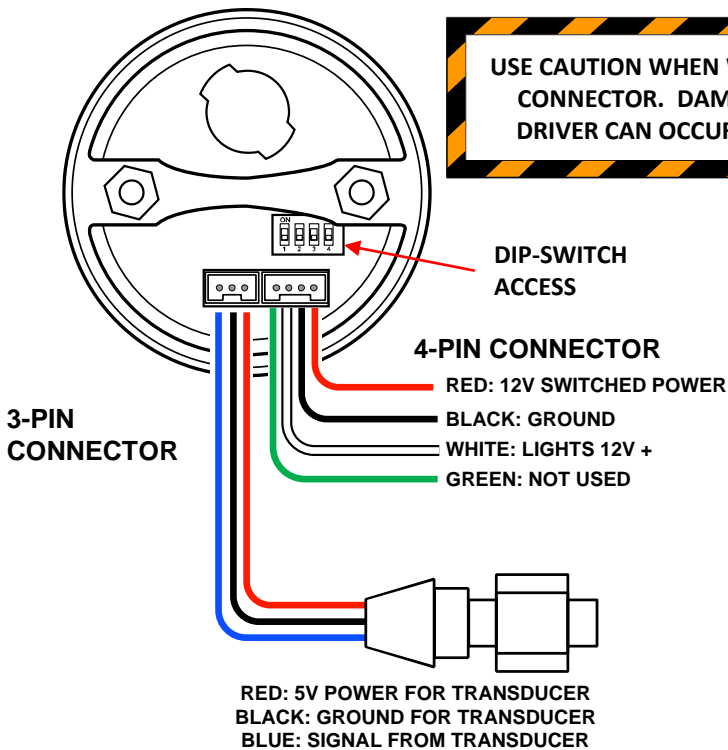

VOLTAGE INPUT	INPUT Ω	1	2	3	4
TRANSDUCER	.5-4.5V	ON	OFF	OFF	ON
0-5 INPUT (AFR, OTHER)	0-5V	ON	OFF	ON	ON

SPEEDOMETER TROUBLESHOOTING

PROGRAM VERSION NUMBER:

This displays the current software version stored in the instrument. The version will vary based on the model you have. It is only required if you have an issue with your speedometer and this information will be useful when contacting NVU for service.

SPEEDOMETER TROUBLESHOOTING BASICS

Speedometers are just like any other gauge in respect that it has the same 3 requirements, power, ground and a signal. Troubleshooting process is the same, start at the end of the system and work your way toward the gauge. As with all gauge systems there are 3 components: The gauge, the wire and the sender or signal source, all three need to be checked for the entire system to operate properly.

- Turn on the key, does the gauge power up?, NO>check power or gauge fault
- Turn on the lights, does the gauge light up? If not , check your ground.

-SPEEDOMETER WILL NOT CALIBRATE

All speedometers require a speed signal to operate properly we first need to check the senders:

HALL EFFECT CABLE OUTPUT REPLACEMENT STYLE:

- Pull the plug from the back of the sender, check for power on the red wire, ground on the black -Pull the sender from the trans, turn on the key and spin the sender with a drill. Speedo operates check mechanical engagement issue with the transmission drive gear, check as needed. Speedo does not operate, check the sender wire using a test lamp

HALL EFFECT SPEED SENDER TEST

- The hall effect sender will alternate positive and negative pulsed when turning the sender slowly by hand. Use a test lamp or multi meter to check by probing the signal wire and the hot then the ground lead

2 WIRE SPEED SENDER, AC SINE WAVE AND MAGNETIC PICKUP

- Check that the ground lead is as short as possible
- Check for continuity between the sender and the gauge
- Pull the sender from the trans, turn on the key and spin the sender with a drill. Speedo operates> mechanical engagement issue with the transmission drive gear, check as needed.

Speedo does not operate, check the sender wire using a test lamp

SPEED SENDER TEST 2 WIRE:

- Set your multi meter on AC voltage, lowest setting or 20V. Probe the sender wire with the red lead, ground the back lead. Spin the tires; you should see between 8-18V on the signal wire. Low or no voltage is a bad or sender that will be going bad soon. This test can also be performed on the cable output style by removing and spinning with a drill to check for a mechanical issue (see above)

NOTE ON FORD STYLE CABLE OUTPUT SENDERS

Check that the drive gear is installed on the sender! The spin with a drill test should be made with the drive gear on and off to rule out an out-of-square drive on the gear

PCM/ECU:

Testing the signal is the same as above methods but it is also important to check the VSS on the transmission to ensure a signal is reaching the PCM first. Without that signal the PCM will not be able to send a signal to the speedometer.

2-1/16" GAUGES-SHORT SWEEP AIRCORE

All NVU short sweep aircore gauges feature rugged movements, shielded metal cases and incandescent lighting. Dial lighting may be perimeter lit (around the dial) or backlit (through the dial). Studded connections require a #6 ring terminal. Always use the proper, matching senders for each gauge. NVU senders for pressure and temperature, factory or aftermarket fuel senders for fuel.

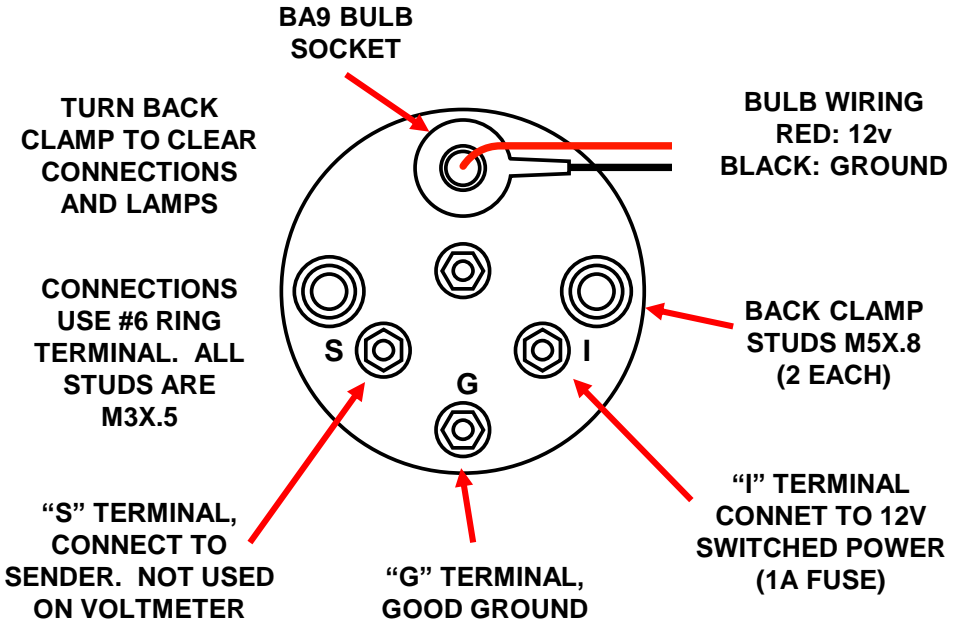

8.8/
11.0

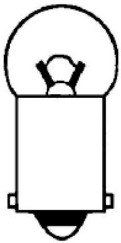

23.5



MCC
Ba9s

BA 9 BULB

If you wish to convert to LED bulbs, simply replace with a BA9 base LED bulb. Choose a bulb that has a wide spread and is not wider than the socket opening. LED lights are different colors and may not light backlit dials the same way.

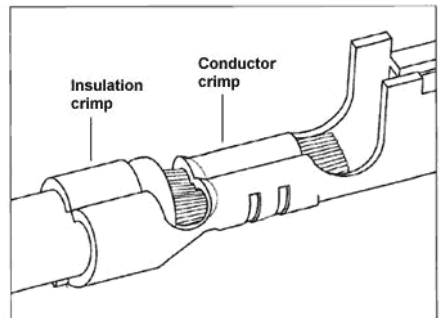

CONNECTIONS

Follow proper terminal crimping procedures for a good connection. A bad crimp is the number one cause of gauge issues and the most difficult to diagnose due to an intermittent problem.

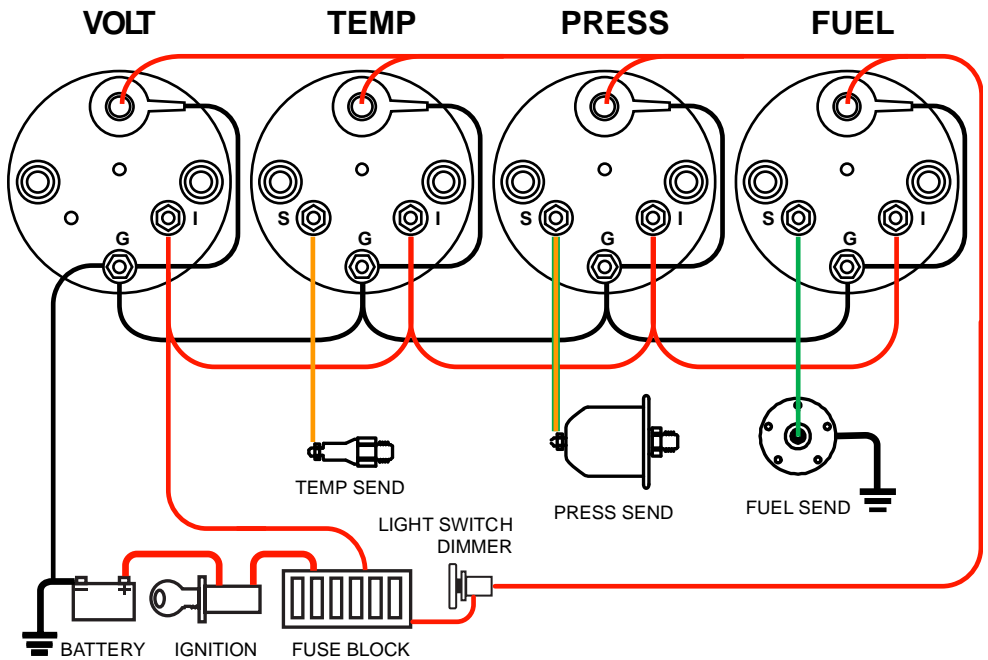

WIRING MULTIPLE GAUGES

Above is an example of wiring a grouping of gauges together. The number one thing to remember is to commonize the basic 3 connections (power, ground, lights) and then run the sender wires. To simplify things even further, you can jump the lamp ground to the gauge ground. Use a minimum of 20 gauge stranded automotive grade wire.

Wire the lighting to the stock dash lights unless you are using LED bulbs, then wire them to the parking lamp circuit. An LED dimmer will be required to dim LED lights.

When installing, you must use the matching senders provided by NVU. OE senders for pressure and temperature will not operate the gauges properly. You may use an OE sender for fuel level when using a matching gauge. See chart next page for more information on OE sender ranges