



**2015-2017 Ford Mustang GT
Kit Number 02126NOS**



OWNER'S MANUAL

CONGRATULATIONS on purchasing your NOS Nitrous Oxide Injection System! Your system is composed of the highest quality components available. It should provide many miles of trouble-free performance when used correctly.

NOTICE: The installation of Nitrous Oxide Systems, Inc. products signifies that you have read this document and have agreed to the terms stated within.

It is the purchaser's responsibility to follow all installation instruction guidelines and safety procedures supplied with the product as it is received by the purchaser to determine the compatibility of the product with the vehicle or the device the purchaser intends to install the product on.

Nitrous Oxide Systems Inc. assumes no responsibility for damages occurring from accident, misuse, abuse, improper installation, improper operation, lack of reasonable care, or all previously stated reasons resulting from incompatibility with other manufacturers' products.

Nitrous Oxide Systems Inc. assumes no responsibility or liability for damages incurred by the use of products manufactured or sold by Nitrous Oxide Systems Inc. on vehicles used for competition or racing.

Nitrous Oxide Systems Inc. neither recommends nor condones the use of products manufactured or sold by Nitrous Oxide Systems Inc. on vehicles, which may be driven on public roads or highways, and assumes no responsibility for damages incurred by such use.

NOS nitrous oxide is legal for use in most states when used in accordance with state and local traffic laws. NOS does not recommend or condone the use of its products in illegal racing activities.

NOS has not pursued California Air Research Board (CARB) exemptions for its kits, hence, they are not legal for use on pollution-controlled vehicles in California. A correctly installed NOS nitrous system should not alter the emission control performance of your vehicle under standard EPA test cycle conditions.

HAZARDS DEFINED

This manual presents step-by-step instructions that describe the process of installing your NOS Nitrous Oxide Injection System. These procedures provide a framework for the installation and operation of this kit. Parts are referenced by name and number to avoid confusion. Within the instructions, you are advised of potential hazards, pitfalls, and problems to avoid. The following examples explain the various hazard levels:

WARNING! Failure to comply with instructions may result in injury or death.

CAUTION! Failure to comply with instructions may result in damage to equipment.

NOTE: This information is important, needs to be emphasized, and is set apart from the rest of the text.

HINT: These special instructions provide a handy work tip.

NITROUS OXIDE INJECTION SYSTEM SAFETY TIPS

WARNINGS

IT IS NOT LEGAL TO ENGAGE NITROUS OXIDE INJECTION SYSTEMS ON PUBLIC ROADS OR HIGHWAYS. NITROUS OXIDE INJECTION SYSTEMS ARE ONLY TO BE ENGAGED DURING SANCTIONED COMPETITION OR RACING EVENTS.

Do not attempt to start the engine if the nitrous has been injected while the engine was not running. Disable the ignition and fuel systems (consult owner's manual) and turn the engine over with the throttle wide open for several revolutions before attempting to start. Failure to do so can result in extreme engine damage.

Never permit oil, grease, or any other readily combustible substances to come in contact with cylinders, valves, solenoids, hoses, and fittings. Oil and certain gases (such as oxygen and nitrous oxide) may combine to produce a highly flammable condition.

Never interchange nitrous and fuel solenoids. Failure to follow these simple instructions can result in extreme engine damage and/or personal injury.

Never drop or violently strike the bottle. Doing so may result in an explosive bottle failure.

Never change pressure settings of safety relief valve on the nitrous bottle valve. Increasing the safety relief valve pressure settings may create an explosive bottle hazard.

Please note that the NOS bottle label has changed to a two-part assembly. The first label is already located on the bottle. Upon filling your bottle with nitrous oxide, apply the (second) material information label in the area indicated in the picture to the right.

NOTE: The material information decal is located in the same plastic bag as the bottle.

WARNING! Once the nitrous bottle has been filled, it must be shipped according to the applicable transportation and shipping regulations!

Do not deface or remove any markings, which are used for content identification.

Nitrous bottle valves should always be closed when the system is not being used.

Notify the supplier of any condition that may have permitted any foreign matter to enter the valve or bottle.

Keep the valves closed on all empty bottles to prevent accidental contamination.

After storage, open the nitrous bottle valve for an instant to clear the opening of any possible dust or dirt.

It is important that all threads on the valves and solenoids are properly mated. Never force connections that do not fit properly.



TABLE OF CONTENTS

WHAT IS NITROUS OXIDE?	4
DO'S AND DON'TS OF NITROUS OXIDE	4
Chapter 1 Introduction to Your NOS Nitrous Oxide Kit	4
1.1 General Information	4
1.2 System Requirements	5
1.3 Kit Components	5
Chapter 2 Kit Installation	7
2.1 Bottle Mounting Instructions	7
2.2 Bottle Orientation	7
2.3 Bottle Installation	7
2.4 Solenoid Fittings and Bracket Mounting	8
2.5 Kit Plate Installation	9
2.6 Fuel and Nitrous Supply Connection	11
2.7 Electrical System	12
2.8 Preparing for Operation	15
2.8.1 Programming the Mini 2-Stage Progressive Controller	16
Chapter 3 Tuning	18
Chapter 4 Determining Optimum System Performance	18
Chapter 5 Alternate Sensor, Actuator, and Switch Components	19
Chapter 6 Routine Maintenance	20
6.1 Nitrous Solenoid Filter	20
6.2 Nitrous Solenoid Plunger	20
6.2.1 General Information	20
6.2.2 Nitrous Solenoid Plunger Disassembly and Inspection	20
Appendix A Troubleshooting Guide	22
Nitrous Oxide Accessories	23

WHAT IS NITROUS OXIDE?

NITROUS OXIDE...

...Is a cryogenic gas composed of nitrogen and oxygen molecules

...Is 36% oxygen by weight

...Is non-flammable by itself

...Is stored as a compressed liquid

...Exists in two grades—U.S.P. and Nitrous Plus:

- ❑ U.S.P. is medical grade nitrous oxide; its common use is dental and veterinary anesthesia. It is also commonly used as a propellant in canned whipped cream. U.S.P. is not available to the public.
- ❑ Nitrous Plus differs from U.S.P. in that it contains trace amounts of sulphur dioxide added to prevent substance abuse. Nitrous Plus is intended for automotive applications and is available for sale to the public.

In automotive applications, Nitrous Plus and fuel are injected into the engine's intake manifold, producing the following results:

- ❑ Lowers engine intake air temperature, producing a dense inlet charge.
- ❑ Increases the oxygen content of the inlet charge (air is only 22 percent oxygen by weight).
- ❑ Increases the rate at which combustion occurs in the engine's cylinders.

DO'S AND DON'TS OF NITROUS OXIDE

Do's

- ❑ Read all instructions before attempting to install your NOS nitrous system.
- ❑ Make sure your fuel delivery system is adequate for the nitrous jetting you have chosen. Inadequate fuel pressure or flow will result in engine damage.
- ❑ Use 14 gauge (minimum) wire when installing electrical system components.
- ❑ Use high-quality connections at all electrical joints.
- ❑ Use PTFE-based thread sealant on pipe-style fittings.
- ❑ Make sure your engine and related components (ignition, fuel system, and driveline) are in proper working condition.
- ❑ **Do not attempt to start the engine if the nitrous has been injected while the engine was not running. Disable the ignition and fuel systems (consult owner's manual) and turn the engine over with the throttle wide open for several revolutions before attempting to start. Failure to do so can result in extreme engine damage.**
- ❑ **Use your NOS nitrous system only at wide-open throttle and at engine speeds above 3000 RPM.**
- ❑ **Install a proper engine to chassis ground. Failure to do so may result in an explosive failure of the main nitrous supply line.**
- ❑ Use a high-quality fuel, as suggested in Chapter 3, Baseline Tuning Suggestions.

Don'ts

- ❑ Engage your nitrous system with the engine off. Severe engine damage can occur.
- ❑ Modify NOS nitrous systems (if you need a non-stock item, call NOS Technical Service for assistance)
- ❑ Overtighten AN type fittings.
- ❑ Use PTFE Tape on any pipe threads. Pieces of PTFE tape can break loose and become lodged in the nitrous or fuel solenoids or solenoid filters. Debris lodged in a nitrous or fuel solenoid can cause catastrophic engine failure.

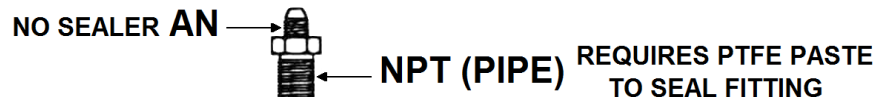

- ❑ Use sealant of any kind on AN type fittings.
- ❑ Allow nitrous pressure to exceed 1100 psi. Excessive pressure can cause swelling or in extreme cases failure of the nitrous solenoid plunger. Solenoid plungers are designed so that pressure-induced failures will prevent the valve from operating. No leakage should occur with this type of failure.
- ❑ **Inhale nitrous oxide. Death due to suffocation can occur.**
- ❑ **Allow nitrous oxide to come in contact with skin. Severe frostbite can occur.**
- ❑ **Use octane boosters that contain methanol. Fuel solenoid failure may occur, producing severe engine damage.**

Chapter 1 Introduction to Your NOS Nitrous Oxide Kit

1.1 General Information

Kit Number 02126NOS was engineered to be a clean and simple installation on 2015-2017 Ford Mustang with a 5.0L Coyote V8 engine. Power output can be increase from 75 to 150 Rear Wheel Horse Power (RWHP) with the supplied jetting. The system can support up to 250+ RWHP with optional jetting, but be aware that an increase over 175 RWHP will require an upgrade to the OEM fuel system in the form of an increased capacity fuel pump or a dedicated, stand-alone, fuel system.

Although this system was engineered for the 2015-2017 Mustang GT, it can be installed on any Ford Coyote engine that utilizes an 80mm, 4 bolt Drive-by-Wire or cable operated throttle body, please note that some modification may be required. The wiring and electrical connections will need to be adapted to the different control system used.

1.2 System Requirements

When used correctly, Kit Number 02126NOS is designed to work with stock 2015-2017 Ford Coyote 5.0L engine and driveline components. The four jet combinations in this kit generate 75, 100, 125, or 150 RWHP gains. Colder plugs (non-projected tip, non-platinum, Iridium or fine wire, gapped at .040") are recommended, NOS utilized **Brisk RR12S Spark Plugs** during our development. If the jetting is increased over 175 HP, it is necessary to upgrade the fuel delivery system to ensure safe operation.

1.3 Kit Components

Before beginning the installation of your NOS kit, compare the components in your kit with those listed in **Table 1**. If any components are missing, please contact NOS Technical Support at 1-866-464-6553.

Table 1 - 02126NOS Parts List

Item	Description	Quantity	NOS Blue/Red Kit P/N	NOS Black Kit P/N
(1)	Bottle Nut Adapter	1	16230NOS	16226NOS
(2)	Bottle Valve Washer	1	16210NOS	16210NOS
(3)	10 lb. Bottle w/ racer safety	1	14745-TPINOS	14745B-TPINOS
(4)	Blow Down Tube	1	16160NOS	16161NOS
(5)	Bottle Mounting Bracket, Short	1	14126-SNOS	14126-SNOS
(6)	Bottle Mounting Bracket, Long	1	14127-SNOS	14127-SNOS
(7)	Cheater N ₂ O Solenoid	1	18000NOS	18000BNOS
(8)	Cheater Fuel Solenoid	1	18055NOS	18055BNOS
(9)	Relay Wiring Harness	1	15604-SNOS	15604-SNOS
(10)	30 Amp Relay	1	15618NOS	15618NOS
(11)	Straight 4AN –1/8" NPT Fuel Filter	1	15571NOS	15570BNOS
(12)	90 Degree 6AN – 1/4" NPT Nitrous Filter	1	15566NOS	15566BNOS
(13)	90 Degree 4AN – 1/8" NPT Adapter	1	17661NOS	AT982204ERL
(14)	Straight 3AN – 1/8" NPT Adapter	1	17951NOS	AT981603ERL
(15)	90 Degree 3AN – 1/8" NPT Adapter	1	17650NOS	AT982203ERL
(16)	Late Model Billet Fuel Line Adapter. Black Anodized Aluminum	1	17002NOS	17002NOS
(17)	0.018" Flare Jet	1	13760-18NOS	13760-18NOS
(18)	0.021" Flare Jet	1	13760-21NOS	13760-21NOS
(19)	0.027" Flare Jet	1	13760-27NOS	13760-27NOS
(20)	0.031" Flare Jet	1	13760-31NOS	13760-31NOS
(21)	0.035" Flare Jet	1	13760-35NOS	13760-35NOS
(22)	0.040" Flare Jet	1	13760-40NOS	13760-40NOS
(23)	0.050" Flare Jet	1	13760-50NOS	13760-50NOS
(24)	0.057" Flare Jet	1	13760-57NOS	13760-57NOS
(25)	6AN 16 ft. Hose	1	15480NOS	15480BNOS
(26)	3AN to 3AN Stainless Nitrous Hard Line	1	52R698A	52R697A
(27)	3AN to 3AN Stainless Fuel Hard Line	1	52R696A	52R695A
(28)	4AN to 4AN 2-FT Hose	1	15231NOS	15231BNOS
(29)	Coyote Plate Assembly	1	40R889A	40R980A
(30)	Screws, Solenoid Mounting 10-32	2	16501-SNOS	16501-SNOS
(31)	Screws, Solenoid Mounting 8-32	2	16506-SNOS	16506-SNOS
(32)	M6X1X60MM, 10.9 FLANGED HEX HEAD BOLT	4	505R87	505R87
(33)	Solenoid Mounting Bracket	1	40R3476-1	40R3476-1
(34)	Mini 2-Stage Progressive Nitrous Controller	1	15974NOS	15974NOS
(35)	Drive By Wire – Electrical Kit	1	85R9801	85R9801
	Rocker Switch	1		
	1/4" Ring Terminal – Red – 18-20 AWG	1		
	1/4" Female Spade – Red – 18-20 AWG	3		
	25 Amp Fuse ATC (large)	1		
	15 Amp Fuse ATM (mini)	1		
	Add-A-Fuse Tap for Mini ATM Fuses	1		
	Posi-Lock Splice Connector 22-20 AWG	4		
	5/16" Ring Terminal – Yellow – 10-12 AWG	2		
	5/16" Ring Terminal – Red – 18-20 AWG	1		
	Posi-Twist Connector 10-22 AWG	2		
	Wire – Red – 20AWG	8ft		
	Wire – Black – 20AWG	8ft		

Figure 1 Kit Number 02126NOS Component Identification

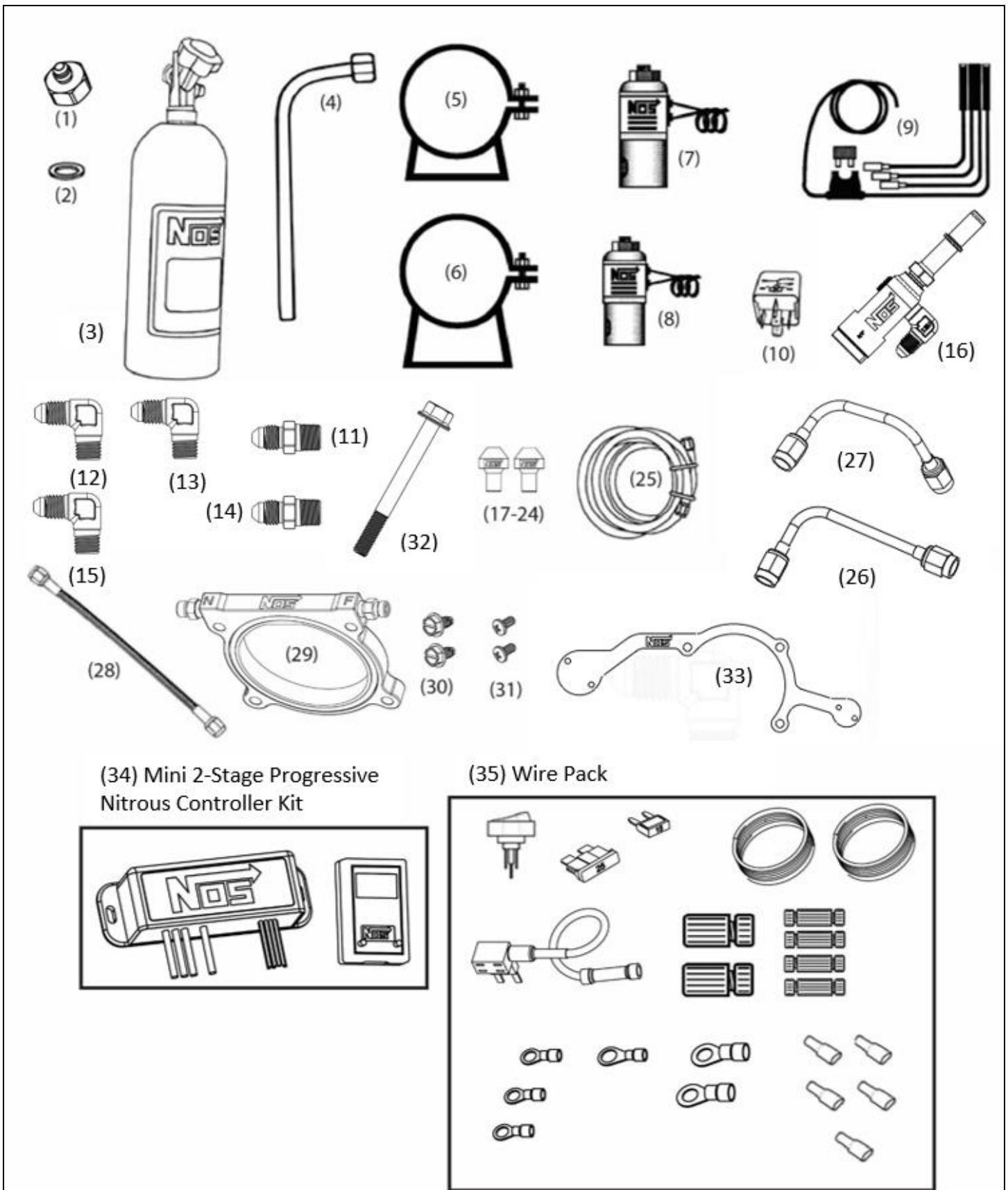

-Parts Shown are not to scale-

Chapter 2 Kit Installation

2.1 Bottle Mounting Instructions

Accurate calibration of your NOS nitrous system depends on the bottle remaining at a stable temperature. Mount the bottle away from heat sources, such as the engine compartment or exhaust system, and away from windows, where the bottle is exposed to direct sunlight.

2.2 Bottle Orientation

Bottle placement is critical to the performance of your NOS nitrous system. It is important to understand how the bottle valve and siphon tube are assembled to properly orient the bottle in your vehicle and ensure that it picks up liquid nitrous while undergoing acceleration. All nitrous bottles are assembled so that the bottom of the siphon tube is at the bottom of the bottle and opposite the bottle label (Figure 2).

Whenever the bottle is mounted in a lay-down position, the valve handle must be towards the front of the vehicle with the label facing up (Figure 3A).

If the bottle is mounted vertically, the valve handle and label must face toward the front of the vehicle (Figure 3B). This orientation will position the siphon tube at the back of the bottle where the liquid N₂O will be during acceleration.

WARNING! DO NOT attempt to remove the siphon tube without completely emptying the bottle of all N₂O and pressure.

A bottle mounted upside-down must have the siphon tube removed before use (Figure 3C). Non-siphon bottles can be specially ordered from NOS.

If the bottle must be mounted parallel to the axles of the vehicle (sideways), the valve handle and label must be angled at approximately 45° toward the front of the vehicle (Figure 3D). This orientation will position the siphon tube toward the rear of the bottle.

NOTE: When using a bottle with a siphon tube, the tall bracket should be at the valve end of the bottle and the short bracket at the bottom (Figure 3E).

The most efficient mounting is the lay-down position (Figure 3A) with the valve handle toward the front of the vehicle. This position allows the greatest amount of liquid to be used before the siphon tube begins to pick up gaseous nitrous oxide.

Find a position in the rear of your vehicle that meets your personal preference. Make sure that it meets the guidelines show in Figure 3.

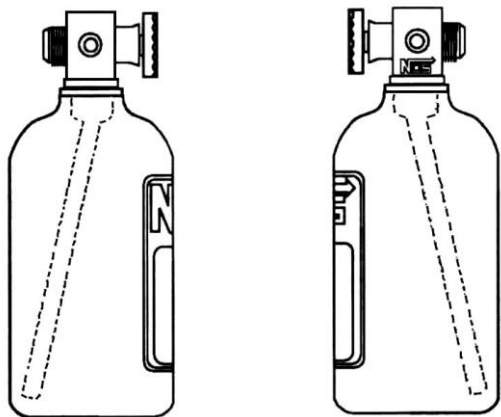

Figure 2 Nitrous Bottle Siphon Tube Orientation

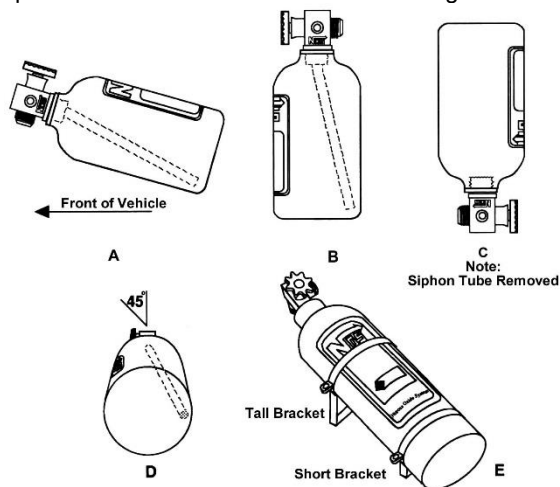

Figure 3 Nitrous Bottle Mounting Orientations

2.3 Bottle Installation

Before mounting a nitrous bottle in a racing vehicle intended for use in sanctioned events, check with the sanctioning association for any rules regarding this subject. Most associations require the bottle to be mounted within the confines of the safety roll cage with the safety pressure relief cap vented away from the driver's compartment. This feature is included in the 02126NOS kit.

1. Install the bottle nut adapter and washer on the nitrous bottle, and tighten securely.
2. Slip the bottle mounting brackets onto the nitrous bottle, as shown in Figure 3E.

3. Locate the bottle assembly in the desired mounting location, ensuring that the location will provide easy access to the bottle valve, hose connection, bracket clamp bolts to facilitate bottle changing and through hole of the blow-down tube.
4. Use the assembled bottle/bracket unit as a pattern to mark for drilling the holes. Drill four 11/32" holes in the mounting surface for the bottle bracket bolts. **Make sure the holes are in a position that does not damage other components.**

CAUTION! When drilling or punching holes for these fasteners, be aware what components, wires, hoses or fluid reservoirs are located or routed behind the general area to avoid vehicle or equipment malfunction.

5. Mount the brackets securely to the surface (recommended minimum of 5/16" bolts or No. 12 sheet metal screws).
6. Secure the nitrous bottle in the mounting brackets and tighten the bracket clamps.
7. Route the blow-down tube through the hole in the trunk, install and fasten to the fitting on the bottle valve.

2.4 Solenoid Fittings and Bracket Mounting

1. Apply a small amount of PTFE thread sealant to the NPT threads of the **nitrous inlet filter adapter** (-6AN to 1/4 NPT 90° adapter with screen) and insert into the **IN** side of the nitrous solenoid. Use a bench vise to tighten the fitting at least 1-1/2 turns after finger tight. See **Figure 4** for alignment.
2. Apply a small amount of PTFE thread sealant to the NPT threads of the **nitrous outlet adapter** (-3AN to 1/8 NPT 90° adapter without screen) and insert into the **OUT** side of the nitrous solenoid. Use a bench vise to tighten the fitting at least 1-1/2 turns after finger tight. See **Figure 4** for alignment.



Figure 4 – Nitrous Solenoid Adapter Alignment



Figure 5 – Fuel Solenoid Adapter Alignment

3. Apply a small amount of PTFE thread sealant to the NPT threads of the **fuel inlet filter adapter** (straight 4AN to 1/8 NPT adapter with screen) and insert into the **IN** side of the fuel solenoid. Use a bench vise to tighten the fitting at least 1-1/2 turns after finger tight. See **Figure 5**.
4. Apply a small amount of PTFE thread sealant to the NPT threads of the **fuel outlet adapter** (straight 3AN to 1/8 NPT adapter without screen) and insert into the **OUT** side of the fuel solenoid. Use a bench vise to tighten the fitting at least 1-1/2 turns after finger tight, see **Figure 5**.
5. Attach the solenoids to the bracket as shown in **Figure 6**. Set assembly aside to be used in **Section 2.5, Step 9**.



Figure 6 – Solenoid bracket assembly

2.5 Kit Plate Installation

WARNING! Do not smoke, carry lighted tobacco, or allow an open flame of any type when working on or near any fuel-related components. Highly flammable mixtures are always present and may be ignited. Failure to follow these instructions may result in personal injury.

1. Disconnect negative cable at the battery.
2. Remove the engine cover.
3. Disconnect the two PCV connectors and sound symposer tube (if equipped) from the air inlet tube.
4. Disconnect the mass air flow connector.
5. Using an 8mm or 5/16" nut driver, loosen the air inlet flex tube clamps. Remove the flex tube or entire air cleaner assembly.



Figure 7 – Intake Air Tube Removal (Holley® Intech Shown, but Factory Intake is Similar)

6. Using an 8mm socket, remove the throttle body bolts and set throttle body aside.

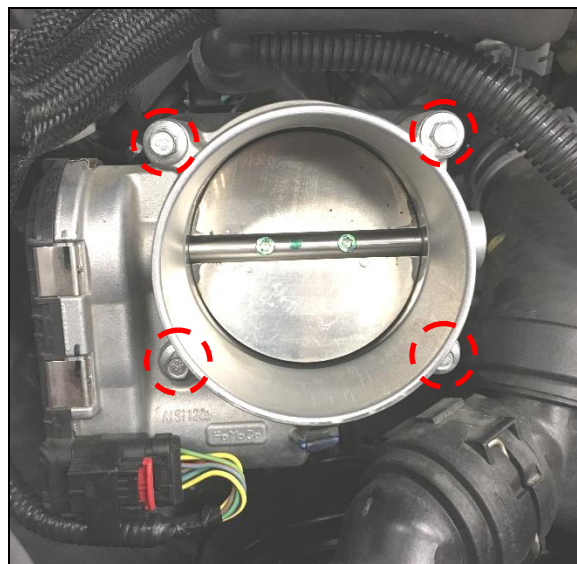

Figure 8 – Throttle Body Removal

7. Install the nitrous plate and throttle body to the intake using one of the new, longer throttle body screws in the hole shown in **Figure 9**. **Do not tighten completely.**

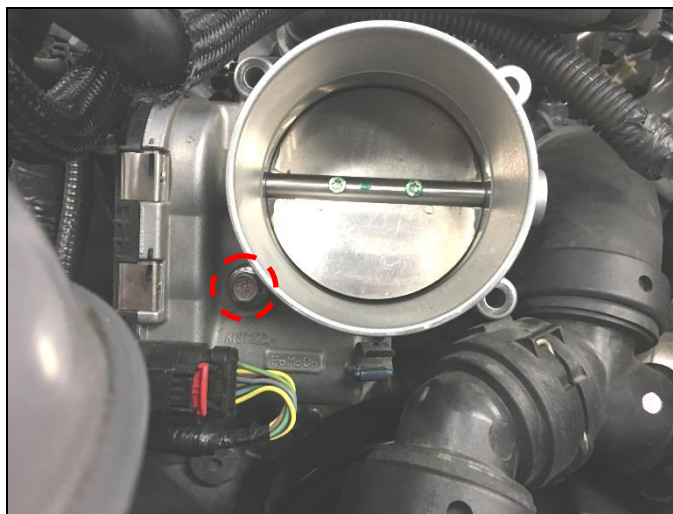
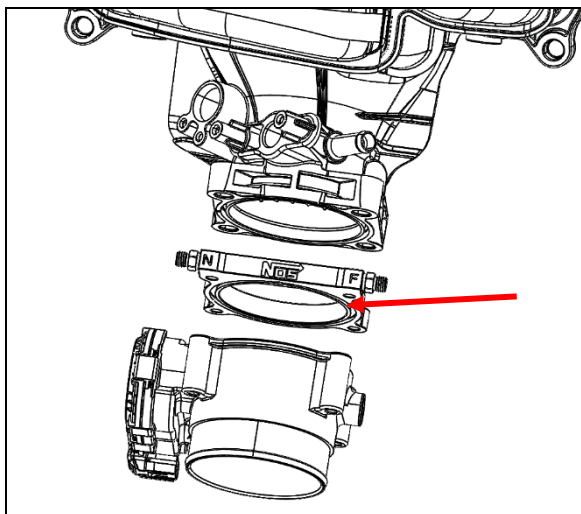

Figure 9 – Nitrous Plate Installation

8. Install the solenoid bracket and solenoids assembly you built in section 2.4 to the outside diameter of the throttle body with the three remaining, longer throttle body screws as shown in **Figure 10**. **Do not tighten completely.**
9. Assemble the nitrous plate supply lines to the appropriate fittings with the desired jets installed as shown in **Figure 11-13**. (See Chapter 3, table 2 for suggested jetting). Route the supply lines as shown in **Figures 12 and 13** and connect them to the appropriate solenoid.

NOTE: We highly recommend the smallest (lowest power) jetting supplied as a starting point. Once total system functionality has been verified, then larger jetting can be installed.



Figure 10



Figure 11



Figure 12



Figure 13

10. Tighten the hardline fittings and then the throttle body screws. Torque to 106 in./lbs. (~8.8 ft./lbs.).

2.6 Fuel and Nitrous Supply Connection

1. Apply a small amount of PTFE thread sealant to the NPT threads of the 90° 1/8" NPT to -4AN fitting, and the 3/8" OE fuel stem. Tighten down the plug (note: no PTFE sealant is required since this already has sealant applied) and install it in the remaining port on the Fuel Tap as shown. Use a bench vise to tighten the fitting at least 1-1/2 turns after finger tight. See **Figure 14** for orientation.



Figure 14 – Fuel Tap Adapter Orientation

WARNING! Fuel in the fuel system remains under high pressure even after the engine is shut off. Before working on or disconnecting any of the fuel lines or fuel system components, the fuel pressure must be relieved. Failure to follow these instructions may result in serious personal injury.

2. Once residual fuel pressure is relieved, place clean rags under fuel rail feed line connector and disconnect by lifting the blue safety latch and pulling the lines apart. There may still be residual fuel in the lines.
3. Install the 3/8" NOS fuel tap (17002NOS) between the fuel rail and the fuel feed line with the red fuel fitting pointing away from the firewall. Apply a light coat of blue thread locker on the retention nut and tightly secure.



Figure 15 – Fuel Tap Orientation

4. Connect the 2 foot -4AN fuel feed line from the 90 degree adapter at the fuel tap to the fuel solenoid straight -4AN filter adapter and tighten.
5. Plumb your nitrous supply line from the bottle to the 90° -6AN filter adapter, **IN** side of the nitrous solenoid being careful not to pinch the line or allow any abrasion from moving parts in the vehicle or exposure to excessive heat.

2.7 Electrical System

WARNING! Death or injury may occur from working on a charged electrical system.

1. Disconnect the ground cable from the battery.
2. Install the NOS arming switch in the vehicle's interior, within easy reach of the driver, and route the provided red and black wires from the switch to the power distribution box on passenger's side of the engine bay.
3. Install the relay in the engine compartment so the relay connector's orange wire will reach the battery (+) terminal located at the front of the main fuse/relay box.
4. Install the NOS 2-stage mini progressive controller to the driver's side wheel well area under the splash guard as shown in figure 17. You will have to remove the driver's side wheel and splash guard to access this area. This is also a good time to route the USB cable into the interior if desired.

NOTE: Figure 17 shows a pass through grommet located behind the driver's front wheel well that is optimal for routing wires into the vehicle.



Figure 16 – Mini 2-Stage Mounting Location

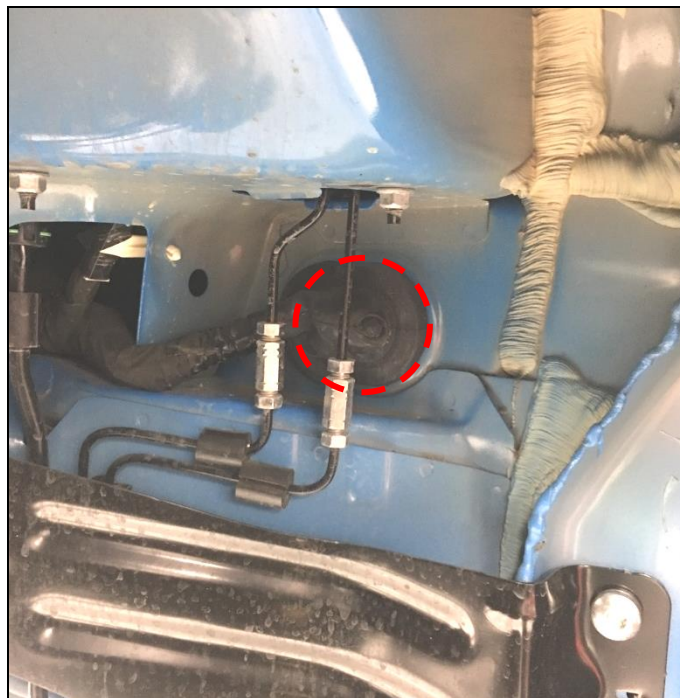

Figure 17 – Wiring Pass Through

5. Connect the orange relay wire (with fuse) to the battery (+) terminal located at the front of the main relay/fuse box.
 6. Connect one wire from the nitrous solenoid to the large blue wire from the mini 2-stage progressive controller and one wire from the fuel solenoid to the large red wire from the mini 2-stage progressive controller, using the provided posi-twist connectors (see assembly diagram on page 14).
 7. Join the remaining two solenoid wires to the smaller blue wire coming from the relay harness using the other Posi-Twist connector.
 8. Connect the green relay wire to a good chassis ground.
 9. Connect the red relay wire to the white wire between the master arming switch (“Load”) and the 2-stage mini controller using one of the provided Posi-Tap connectors (see assembly diagram on page 14). This tap can be installed close to the Mini 2-Stage Controller in the engine bay.
 10. Connect the “Supply” terminal (supplied red wire from step 2) on the master arming switch to the blue crimp connector on the provided Add-A-Tap fuse holder. Find a suitable 15 amp fused circuit in the main fuse/relay box in the engine bay to plug into. Install both the supplied 15 amp mini fuse and the fuse removed from the fuse box into the Add-A-Tap fuse holder.
 11. Ensure the chosen switched power supply 15 amp fuse location is powered only in the ON/RUN position of the ignition. This can be verified by using a test light before connecting the Add-A-Tap fuse holder.
 12. Connect the digital ground (small black) wire to a clean ground not shared with high voltage grounds. This is the same wire from step 2 above, the wire from the Earth terminal will be T-taped into this wire using the Posi-Tap connector.
 13. Connect the “Earth” terminal on the master arming switch (supplied black wire from step 2) to the digital ground wire coming from the 2-stage mini controller (small black wire) using one of the provided Posi-Tap connectors (see assembly diagram below).
 14. Connect the 2-stage mini progressive ground (large black wire) to a good battery/engine ground using the supplied ring lug connector.
- NOTE:** It is important to ensure that a good ground path to the battery is used. This is the high current ground used by the fuel and nitrous solenoids.
15. Using a supplied Posi-Tap connector (see assembly diagram below), connect the green tach signal wire from the 2-stage mini progressive controller to the #1 coil driver signal wire (White/Violet). This will be one of the wires on the 4 wire connector located on the ignition coil (**Figure 18**).



Figure 18 – Tach Signal Wire Connection

16. Using a supplied Posi-Tap connector, connect the white with blue stripe and white with red stripe TPS signal wires from the 2-stage mini progressive controller into the TPS signal wire on the throttle body. This will be a green wire with a purple stripe, located on the connector at the passenger's side of the throttle body (**Figure 19**).



Figure 19 – TPS Signal Wires Connection

17. Install the relay into the relay connector and reconnect the battery.

NOTE: When connecting the battery, be aware of any excessive arcing or sparks from the battery to the negative cable. This could be an indication of a wire that has been shorted to ground.

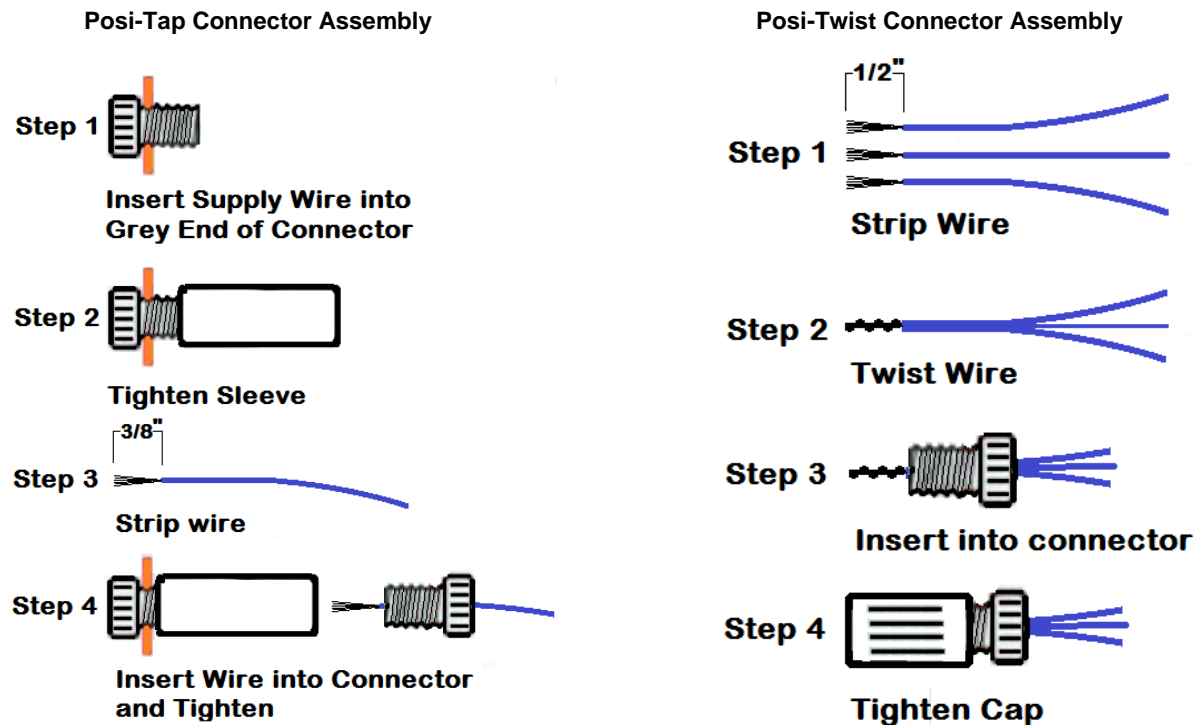

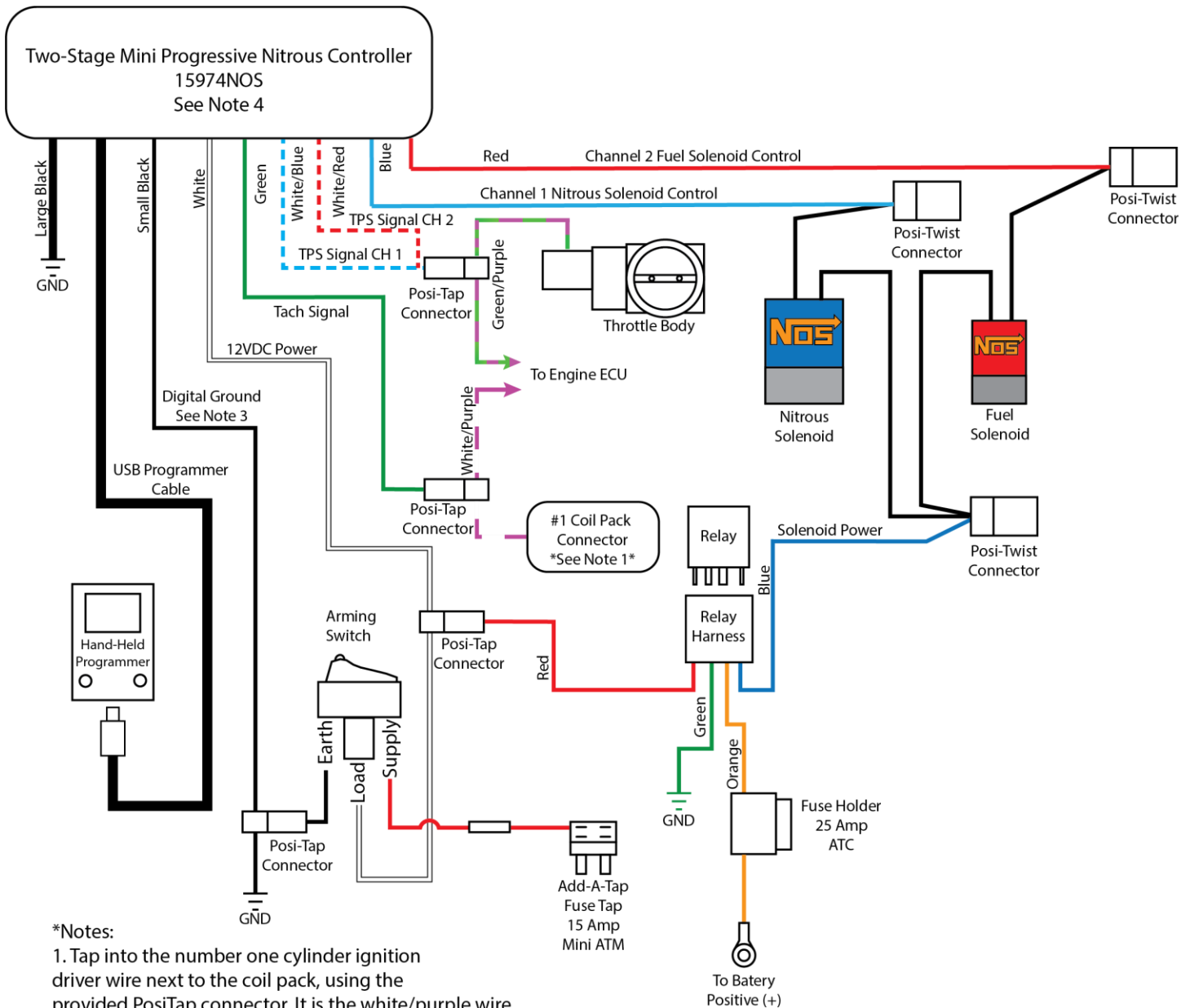

Figure 20 Electric Wiring Diagram

2.8 Preparing for Operation

1. Install a fully charged nitrous bottle. The pressure gauge should read 900-1000 psi at operating temperature/pressure.
2. Slowly open the nitrous bottle valve while listening and looking for any leaks at the bottle fittings as well as the fittings on the solenoids in the engine compartment.
3. If no leaks are found, slightly loosen the -6 AN supply line fitting at the blue nitrous solenoid. Allow the air to leak from the fitting until nitrous starts to fog out, then retighten the fitting. **NOTE: Nitrous is very cold and can cause burning and irritation to the skin, we recommend wearing gloves during this procedure.**
4. Turn the ignition power to the ON position, but do not start the car.

5. Turn the Master Enable switch to the ON position. The red LED should be on now.
6. Connect the hand held programmer to the USB cable and program the unit to the recommended base settings shown in section 2.8.1. Additional instructions are included with the 2-stage mini progressive controller for creating custom settings.
7. Once programming is complete, turn the ignition switch off for 10 seconds, then back to the ON position; do not start the engine yet.
8. Verify the programmer display shows an “r r”. If display show any other values than “r r”, refer to page 2 of the Mini 2-Stage controller instructions for more information.
9. You are now ready to drive the car and test the operation of the nitrous system.

WARNING! It is VERY important to use caution and good safety practices when testing and using any nitrous oxide system. We do not recommend the use of nitrous on any public streets or highways. It is recommended to only test and use nitrous in a controlled, closed course location, such as a race track.

WARNING! Never activate nitrous with the vehicle in “NEUTRAL” or “PARK”!

WARNING! Never activate nitrous at engine speeds below 3000 RPM, or engine damage may result!

WARNING! SEVERE ENGINE DAMAGE MAY OCCUR IF NITROUS IS ACTIVATED WHILE TRACTION CONTROL DEVICES ARE ENABLED. TRACTION CONTROL DE-ACTIVATION MUST BE CYCLED EVERY TIME THE IGNITION SWITCH IS CYCLED.

2.8.1 Programming the Mini 2-Stage Progressive Controller

The following settings are a good baseline from which to start. Additional or Custom settings can be programed by following the User Guide supplied with the Mini 2-Stage controller.

Switch #1 - toggles through the configuration menu. As you toggle through the configuration menu, the stored value will be displayed. Use this switch to toggle to the next step in programming mode (Press switch #1, 2 times).

Switch #2 - increments the flashing value that was selected by switch #1.

LED A.B.C - displays the configuration step number and its setting
 A = this is the step being programmed
 B & C = value for the current configuration step

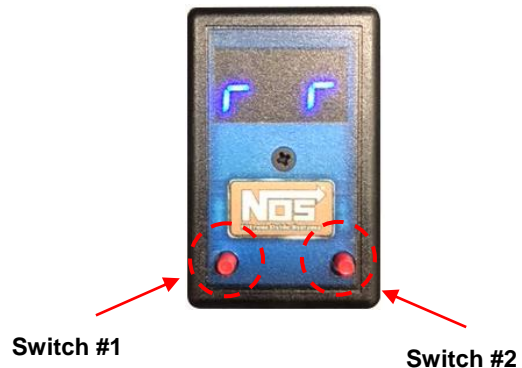

To enter the programming mode:

Press and hold both switches until “Pro” is displayed. Now release the switches and the unit will automatically go to the first configuration step.

- | | |
|---|----------------------------|
| STEP F. SOLENOID FREQUENCY (Hz) = 20 | Display reads; F.20 |
| STEP C. RPM SIGNAL SET-UP = 00 | Display reads; C.00 |
| STEP P. RAMP PAUSE MODE = 00 | Display reads; P.00 |

Channel 1 – Nitrous Solenoid Set Up

1. ACTIVATION RPM = 45 (4500rpm)
NOTE: This setting can range from a minimum of any RPM greater than 0 rpm (3000 rpm recommended) up to a maximum of 9900 rpm. Display reads; 1.45
2. DEACTIVATION RPM = 65 (6500rpm) Display reads; 2.65
NOTE: This setting should be set to 200 RPM below engine rev limiter (maximum of 9900 rpm).
3. DELAY TIME = 0.2 (seconds) Display reads; 3.0.2
4. START % = 20 (20%) Display reads; 4.20
5. RAMP TIME = 2.0 (2.0 seconds) Display reads; 5.2.0
6. END % = 99 (99%) Display reads 6.99
NOTE: (99% = 100 %)
7. CONTROL OUTPUT DELAY TIME = 00 Display reads 7.0.0
8. TPAS MODE = 02 (90% of WOT voltage) Display reads; 8.02
9. TPS SETTING = see below to calibrate this setting

Press switch #2 to read and display the TPS signal. Momentarily press the accelerator pedal completely to the floor and release, to reach 100% throttle – the unit only needs to see WOT for a fraction of a second. Now press switch #1 to save the displayed value. (You do not have to be at WOT when you press switch #1 to save.) **Engine should not be running, but ignition must be ON!**

Channel 2 – Fuel Solenoid Set Up

1. ACTIVATION RPM = 44 (4400rpm)
NOTE: This setting can range from a minimum of any RPM greater than 0 rpm (3000 rpm recommended) up to a maximum of 9900 rpm. Display reads; 1.44
2. DEACTIVATION RPM = 65 (6500rpm) Display reads; 2.65
NOTE: This setting should be set to 200 RPM below engine rev limiter (maximum of 9900 rpm).
3. DELAY TIME = 0.0 (seconds) Display reads; 3.0.0
4. START % = 20 (20%) Display reads; 4.20
5. RAMP TIME = 1.0 (1.0 second) Display reads; 5.1.0
6. END % = 99 (99%) Display reads 6.99
NOTE: (99% = 100 %)
7. CONTROL OUTPUT DELAY TIME = 00 Display reads 7.0.0
8. TPAS MODE = 02 (90% of WOT voltage) Display reads; 8.02
9. TPS SETTING = see below to calibrate this setting

Press switch #2 to read and display the TPS signal. Momentarily press the accelerator pedal completely to the floor and release, to reach 100% throttle – the unit only needs to see WOT for a fraction of a second. Now press switch #1 to save the displayed value. (You do not have to be at WOT when you press switch #1 to save.) **Engine should not be running, but ignition must be ON!**

NOTE: Activating the fuel solenoid before the nitrous solenoid allows the system to recover from the initial drop in fuel pressure, this avoids a lean condition and allows for the most optimal conditions for the nitrous.

NOTE: The user must continue through the setup for stage 1 and stage 2 until they see END. If the power is shut off, or the system reset in any way, the changes will not be saved.

Chapter 3 Tuning

Table 2 Tuning Suggestions for NOS Kit Number 02126NOS

Configuration	N ₂ O Jetting	Fuel Jetting
75 RWHP*	35*	18*
100 RWHP*	40*	21*
125 RWHP*	50*	27*

Configuration	N ₂ O Jetting	Fuel Jetting
150 RWHP*	57*	31*
175 RWHP**	60	36
200 RWHP**	65	39

*Jetting Included in kit
 **Will require an upgraded fuel system

NOTE: Figure 21 shows a 179 Rear Wheel Horsepower increase on Holley's Dynojet Chassis Dyno. This test was performed on a 2017 Ford Mustang GT with a 5.0L Coyote engine and a 6-speed manual using 10 gallons of 108 octane race fuel, Brisk RR12S spark plugs, Hooker Black Heart Exhaust, stock fuel injectors and stock fuel pump. This power level is at the extreme limit of the OEM fuel system. We **HIGHLY** recommend upgrading the fuel pump before attempting to run this power level. Severe engine damage can result from prolonged use of running this power level with an OEM fuel system.

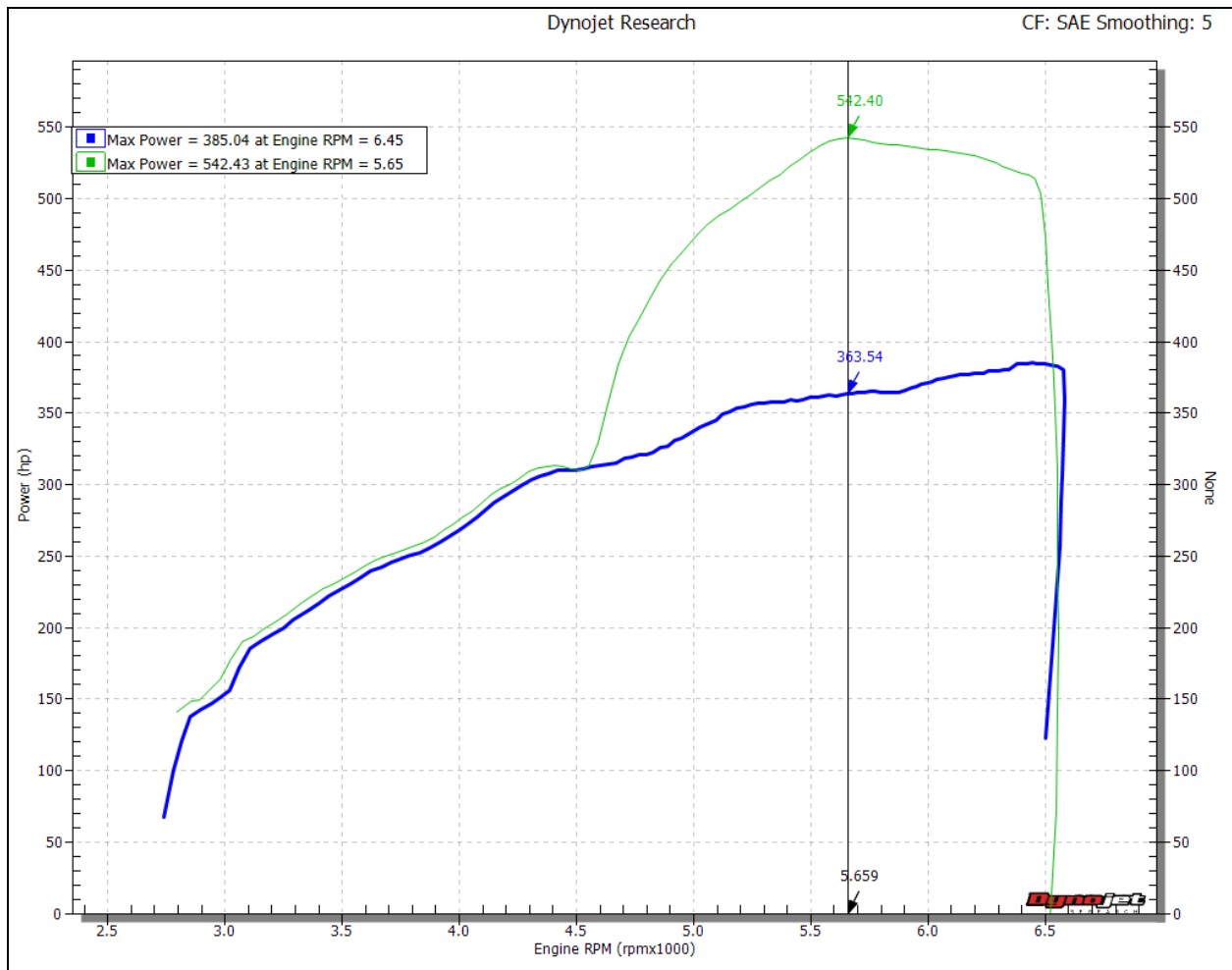

Figure 21 – 175HP Shot Dyno Graph

Chapter 4 Determining Optimum System Performance

The jetting combinations included in your 02126NOS kit are intended to generate power gains of 75 to 150 HP. These combinations are designed to be used with 950 psi of nitrous bottle pressure and 60 psi of flowing fuel pressure. Spark plug inspection and/or the use of a wide-band O₂ sensor can determine optimum system performance. Inspection of the spark plugs should be done on a consistent basis.

1. Perform a dynamometer pull or a full throttle pass down the racetrack. Note the power reading or vehicle mph (not e.t.). Examine the spark plugs for an indication of lean or rich nitrous/fuel conditions (refer figure 22 to for tips on reading the spark plugs). For this application, the air/fuel mixtures at WOT tend to be very rich in stock form. You may wish to examine a plug after a NO-nitrous pass or dyno pull for comparison purposes.

CAUTION! Terminate test immediately if pinging, knocking, detonation is noticed during the test. If engine does not pull hard (expected HP or torque gains are not observed), terminate test and investigate before continuing.

- 1A. If spark plugs appear to be excessively rich, decrease the fuel jet size 1 step (ex. 28 to 26 or 26 to 24).
- 1B. If spark plugs appear to be excessively lean, increase the fuel jet size 1 step.
- 1C. If spark plugs have a “like new” appearance on the porcelain and electrode, do not make a fuel jetting change.

2. Repeat these steps until the desired mixture is obtained.

How to Read Spark Plugs from a Nitrous Oxide Injected Engine

A. Correct Timing, Mixture, and Spark Plug Heat Range

The ground strap retains a “like new” appearance. The edges are crisp, with no signs of discoloration. The porcelain retains a clear white appearance with no “peppering” or spotting.

B. Excessively Rich Mixture

The porcelain may be fuel stained, appearing brown or black. In extreme cases, the ground strap, electrode, and porcelain may be damp with gasoline, or smell of fuel.

C. Detonation

The edges of the ground strap may become rounded. The porcelain has the appearance of being sprinkled with pepper, or may have aluminum speckles. During heavy detonation, the ground strap tip may burn off. This phenomenon can result from excessive ignition timing, too high a heat range spark plug, inadequate fuel octane, or excessively lean mixture.

D. Excessively Lean Mixture

The edges of the ground strap may become rounded. Under moderate overheating, the tip of the ground strap can discolor, usually turning purple, or the entire ground strap can become discolored.

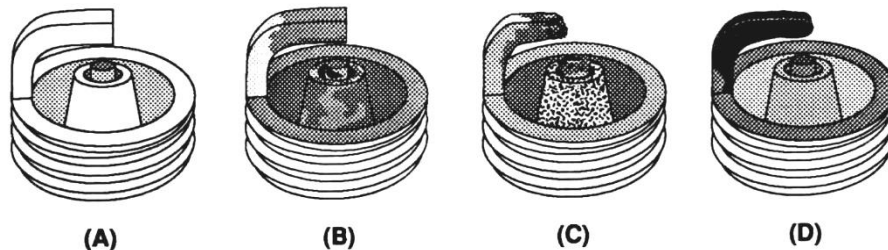

Figure 22 Spark Plug Condition

Chapter 5 Alternate Sensor, Actuator, and Switch Components

1. In some racing applications, “pushbutton solenoid” activation is preferred. In such instances, the solenoid is connected to ground via a pushbutton momentary switch P/N 15610NOS. Almost all multi-point fuel injection systems are provided with throttle position sensors. NOS has throttle position sensor controllers that activate the solenoids, according to the sensor voltage output. This form of solenoid activation procedure is commonly referred to as “TPS activation”.
2. NOS offers fuel pressure safety switches. These switches only allow the nitrous and fuel solenoid to be activated, if a safe fuel pressure is existent in the enrichment fuel supply system.
3. Activation of nitrous at low RPM levels can be detrimental to the engine performance and engine life. The RPM window activation switch only allows the nitrous and fuel solenoid to be activated if a safe RPM value has been reached. Some factory engine control units cut off the ignition if a maximum RPM level is reached. Although the engine is still at WOT and the solenoids are activated no nitrous and fuel is combusted. When the engine reaches safe RPM levels ignition is restored but excess fuel and nitrous are present in the manifold. Some applications may even cut the fuel injector to limit engine RPM. Because the engine is at WOT, the nitrous solenoid is still open thus generating an extreme lean condition. Under both conditions engine damage might occur. The RPM window activation switch cuts off the supply of fuel and nitrous until safe RPM levels are reached. The low and high RPM values can be trimmed according to the application.

Chapter 6 Routine Maintenance

6.1 Nitrous Solenoid Filter

When nitrous bottles are refilled, they can become contaminated with debris if the refiller does not have adequate filtration in his transfer pump mechanism.

You should periodically (after every 20-30 pounds of nitrous usage) examine the mesh in the nitrous filter for debris.

To clean the filter, follow the steps below:

1. Close the valve on the nitrous bottle.
2. Empty the main nitrous feed line.
3. Disconnect the main nitrous feed line from the nitrous solenoid.
4. Remove the nitrous filter fitting from the nitrous solenoid.
5. Remove **all** PTFE paste debris from the solenoid inlet port threads and from the nitrous solenoid filter pipe threads.
6. Examine the mesh in the nitrous filter fitting for contaminants. Blow out debris with compressed air, if necessary.
7. Apply fresh PTFE paste to the nitrous filter pipe threads. Reinstall the filter in the nitrous solenoid.
8. Reconnect the main nitrous supply line to the nitrous solenoid.

6.2 Nitrous Solenoid Plunger

6.2.1 General Information

The seals used in NOS nitrous solenoid plungers are constructed from materials which are designed to be used with nitrous oxide. When kept free from fuel contaminants or from over pressurization, they should provide trouble free performance.

You should periodically (after every 20-30 pounds of nitrous usage) examine the seal in the nitrous solenoid plunger.

The seals used in NOS nitrous solenoid plungers are designed to work at pressures up to 1100 psi. Exposing the plunger to excessive pressure (whether the vehicle is sitting or in-use) can result in the seal in the plunger swelling or in extreme cases disintegrating.

NOTE: The seals are designed so that if they fail due to over pressurization, they will not leak, the valve will just fail to flow nitrous oxide.

Swelling of the nitrous solenoid plunger seal will reduce nitrous flow (causing an excessively rich nitrous/fuel condition and a loss of power).

6.2.2 Nitrous Solenoid Plunger Disassembly and Inspection

1. Close the valve on the nitrous bottle.
2. Empty the main nitrous supply line.
3. Remove the retaining nut from the nitrous solenoid.
4. Remove the coil and housing from the nitrous solenoid base.
5. Unscrew the stem from the nitrous solenoid base. Do this by double nutting the stem, or by using a solenoid stem removal tool. **Do not use pliers on the solenoid stem. Damage to the stem will result.**
6. Remove the stem, spring, and plunger from the solenoid base.
7. Examine the plunger seal for swelling. The seal surface should be flat, except for a small circular indentation in the center of the seal;

A fuel-contaminated seal will protrude from the plunger and be dome-shaped. A fuel-contaminated seal may return to its original shape if left out in the fresh air for several days. It may then be returned to service.

A seal, which has been over-pressurized, may be dome-shaped, or the sealing surface may be flat with the seal protruding out of the plunger. A dome-shaped seal may return to its original shape if left out in the fresh air for several days. It may then be returned to service. A seal, which is flat, but protrudes from the plunger body has probably failed internally and should be replaced.

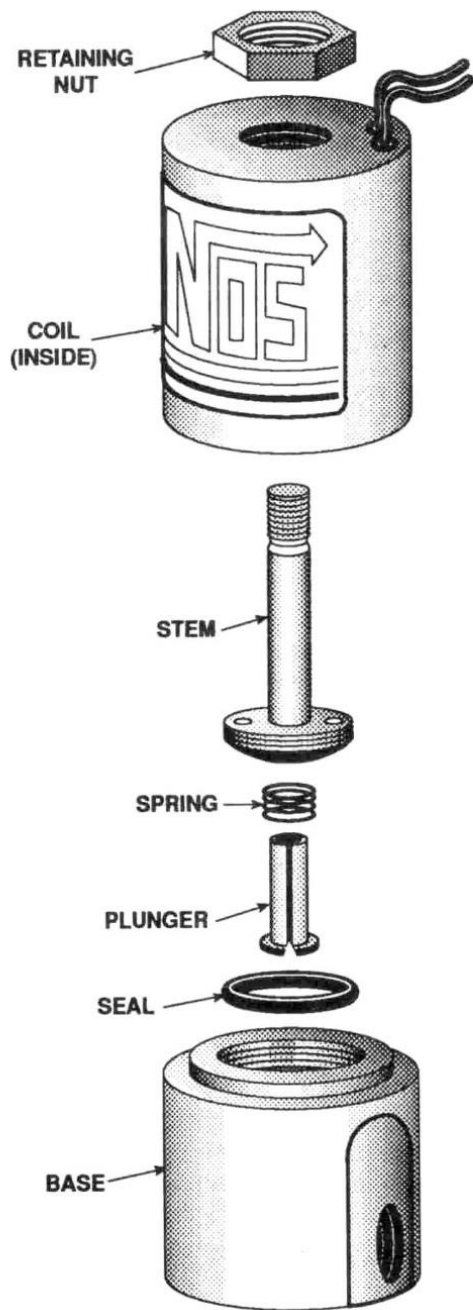

Figure 23 - Exploded View of a Typical Solenoid

Appendix A Troubleshooting Guide

The troubleshooting chart on the following pages should help determine and rectify most problems with your installed NOS system.

PROBLEM	POSSIBLE CAUSES	DIAGNOSTIC PROCEDURE	CORRECTIVE ACTION
No change in engine speed when the system is activated.	System wired incorrectly.	Compare wiring to schematic.	Wire per instructions.
	Restricted fuel line.	Inspect fuel line for restrictions (crimped or plugged).	Remove restrictions.
	Malfunctioning fuel solenoid.	Remove and inspect solenoid.	Repair/replace solenoid.
	Malfunctioning nitrous solenoid.	Remove and inspect solenoid.	Repair/replace solenoid.
Engine runs rich when system is activated.	Bottle valve not fully opened.	Check bottle valve.	Open valve fully.
	Bottle mounted improperly.	Check bottle orientation.	Mount bottle properly.
	Plugged nitrous filter.	Inspect filter.	Clean/replace filter.
	Low bottle pressure.	Check bottle temperature.	Set bottle temperature to 80° to 85°F.
	Inadequate nitrous supply.	Weigh bottle.	Fill bottle. 1-800-997-3345 for refills nearest you.
	Mismatched N ₂ O/fuel jetting.	Compare jetting to recommended values.	Install correct jets.
	Excessive fuel pressure.	Install fuel pressure gauge in the fuel line. Measure the pressure during acceleration, with the system activated.	Regulate pressure down, or install smaller fuel jetting.
	Loose nitrous solenoid wiring.	Inspect the solenoid wiring.	Repair wiring.
Malfunctioning nitrous solenoid.	WARNING: <i>Solenoid discharges nitrous at a high rate. Don't inhale nitrous; death may occur. Skin contact may cause frostbite.</i> Close bottle valve. Disconnect the solenoid outlet port. Disconnect the solenoid (+) lead. Open the nitrous bottle valve. Briefly connect the +12V to the solenoid. Solenoid should discharge N ₂ O at a high rate.	Repair/replace solenoid.	
No change in performance when system is activated.	System wired incorrectly.	Compare nitrous wiring to schematic.	Wire system per instr.
	Loose ground wire(s).	Connect 12V test light to battery (+) terminal. Check for continuity at grounds noted in schematic.	Tighten/repair loose ground(s).
	No power to arming switch.	With vehicle ignition on, connect 12V test light to battery (-) terminal. Check for power at pole #1 on arming switch.	Repair wiring.
	Damaged fuse in switched power (15 amp)	Remove and inspect 15 amp fuse	Replace Fuse
	Damaged fuse in solenoid relay battery power (30 amp)	Remove and inspect 30 amp fuse	Replace Fuse
	Malfunctioning arming switch.	With vehicle ignition on, turn arming switch ON. Connect 12V test light to battery (-) terminal. Check for power at red wire on arming switch.	Replace arming switch.
	Malfunctioning Progressive Controller	Refer to the installation instructions for the NOS Mini 2-Stage Controller, part number 15974NOS	
Engine detonates mildly when system is activated.	Overly rich fuel condition.	Check for black smoke or backfiring through exhaust with system activated.	Install smaller fuel jet or check for restriction in fuel supply.
	Inadequate octane fuel.		Use higher octane fuel; up to 116VPC-16.
	Incorrect spark plug type or heat range.	Do not use "fine wire" or iridium type spark plugs. Reduce spark plug heat range by 1 or 2 steps.	Replace spark plugs with correct type and heat range.

Engine detonates heavily when system is activated.	Too much nitrous flow.		Reduce nitrous jetting.
	Inadequate fuel delivery due to restricted fuel filter.	Inspect fuel filter.	Clean or replace filter.
	Crimped fuel line.	Inspect fuel line.	Replace crimped line.
High rpm misfire when system is activated.	Weak fuel pump.	Install fuel pressure gauge. Run engine under load at wide-open throttle, with system activated.	Repair/replace fuel pump.
	Excessive spark plug gap.	Inspect spark plugs.	Set spark plug gap at 0.030" to 0.035".
Surges under acceleration when system is activated.	Weak ignition/ignition component failure.	Inspect components (plug wires, coils, etc.)	Replace worn components.
	Inadequate supply of nitrous.	Check bottle weight.	Replace with full bottle.

Nitrous Oxide Accessories

NOS systems are calibrated for optimum performance with a bottle pressure of 950 psi. The pressure will change with temperature. Heater kits are thermostatically controlled to keep the bottle near 85° F to provide correct pressure. **Bottle Heater (P/N 14164NOS)** is available for 10 & 15 lb. bottles. **Bottle Heater, P/N 14169NOS**, is pressure-controlled to keep your bottle at 950 psi.

Insulating the bottle helps maintain pressure by keeping heat in the bottle when it's cold, or heat out when it's hot outside. The blankets are made of a rugged, easily cleaned Nylon outer shell with insulation. It's also an excellent "dress up" accessory and perfect for "covering" battle-scarred bottles. **Bottle Blanket (P/N 14165NOS)** is a 7" diameter blanket for the 10 lb. bottle.

#10 Bottle Heater P/N 14169NOS



#10 Bottle Blanket P/N 14165NOS



The **Nitrous Pressure Gauges, P/N 15910NOS (-4AN lines) or P/N 15912NOS (-6AN lines)** [0-1500 PSIG] are designed to provide accurate ($\pm 2\%$ of full scale) readings of fuel pressure in carbureted applications.

The **Fuel Pressure Gauges, P/N 15906NOS** [0-120 PSIG] **and P/N 15900NOS** [0-15 PSIG] are engineered to provide accurate ($\pm 2\%$ of full scale) readings for high and low fuel pressure applications.

Nitrous & Fuel Pressure Gauges

