

Installation Guide

Front Strut Bar to Sub Frame Bushing

Audi A4/S4/RS4 95 - on, A6/S6/RS6 97 - 04, A8/S8 98 - 03

Z 5174

(Always refer to the current catalogue for complete application listings)

N.B: This installation guide should be used in conjunction with the workshop manual.

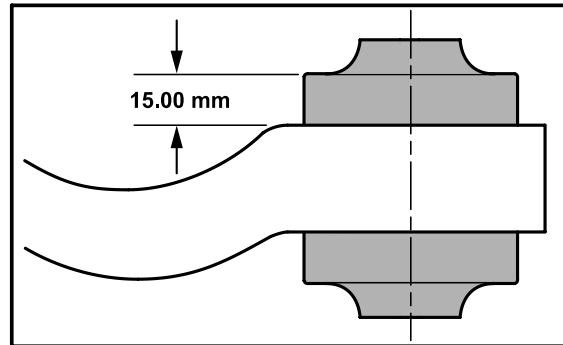
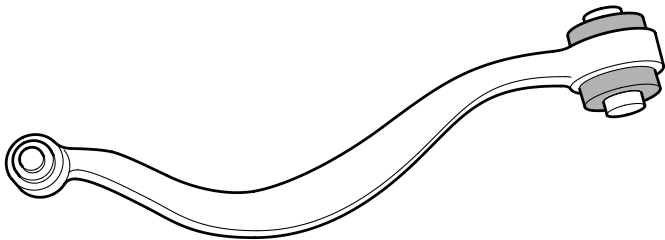

W83385 is a standard replacement kit

KCA422 will +/- the caster both sides of the car

Note: Polyurethane bushings must be fitted to both sides of the vehicle

REPLACEMENT PROCEDURE

1. Wheel align the vehicle before the job is started and note settings.
2. With the vehicle on jack stands/hoist, remove the wheels then mark the strut bars left and right and remove the strut bars.
3. Use a hydraulic press to remove the O.E. bush, make sure the O.D. of the pressing tool is no larger than 64.20mm.
4. Then with reference to the diagrams fit the new bushes, leaving an equal amount of the shell protruding from the arm (15mm). Note each offset bush will +/- the caster by approx 0.75 degrees.
5. Using the grease supplied lubricate the bore of the bush and the outside of the crush tube, then push the crush tube into the bush.
6. Refit the strut bar to the vehicle, refit sub frame bolts/nuts and tighten all bolts using the manufacturers torque settings.
7. Carry out a wheel alignment.

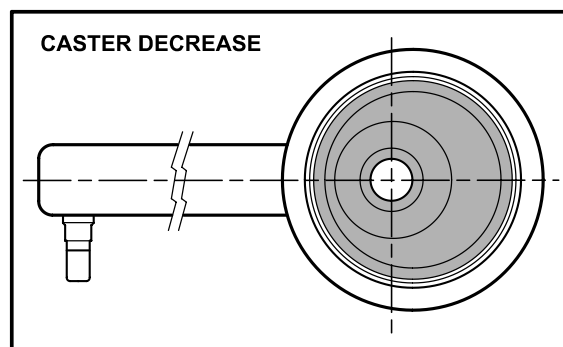
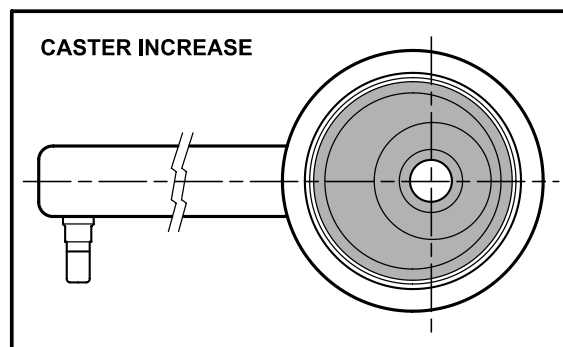
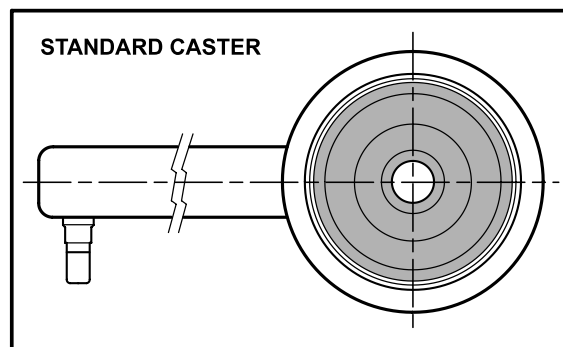

N.B: It is recommended that a licenced workshop or trades person carry out the above procedure and that workshop manual and relevant safety procedures are followed in addition to the above.