

REMOTE BOTTLE OPENER

PN 11107

Congratulations on purchasing the worlds' first and finest remote bottle opener. This opener will allow you to stay in the comfort of your seat and open your nitrous bottle. Nitrous Express has designed the opener to work with NX bottles, but may be adapted to fit all other bottles valves.

The motor has been installed on the main body for your convenience. The motor can be rotated to 4 different positions if clearance is needed.

1. Remove the bottle from the vehicle, leaving the nut and nipple intact. Install a cap onto the nipple to prevent nitrous flow. Open the valve completely (Do not over open the valve). This will give the proper installation height for the opener to work without binding. (See Illustration A)
2. Remove plastic cap on hand wheel. Using a ½ wrench remove the hand wheel from the top of the bottle valve.
3. Install the adaptor collar around the top of the bottle valve just below the hand wheel. (See Illustration B.) Now tighten allen bolt on collar to secure it to the valve.
4. Install the valve opener gear over the square brass stem on the top of valve. (See Illustration B)
5. Install the nut from the original hand wheel onto the opener gear. The opener gear now serves a dual purpose, becoming a hand wheel when the body is removed to assist in filling the nitrous bottle.
6. Install the main body over valve and collar making sure the gear on the drive motor meshes with the bottle gear correctly and the hole for the thumbscrew is properly aligned. **NOTE: IF THE GEARS DO NOT MESH CORRECTLY, THE MAIN BODY WILL NOT SET DOWN PROPERLY AND DAMAGE TO THE DRIVE MOTOR TRANSMISSION IS POSSIBLE**
7. Once the main body is installed correctly, tighten the thumbscrew securely (HAND TIGHT!). (See Illustration C)
8. Wiring your system. (See Illustration D) Cut the blue and black wires 10 inches from the motor. Install

Illustration A

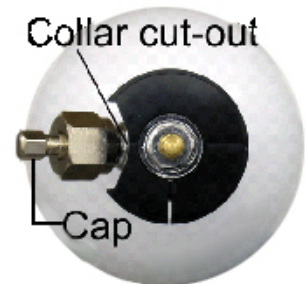

Illustration B



Illustration C



the seals and male weather pack terminals on the motor side wires. The wires going to the activation switch will use female terminal ends. Slide the terminals into the weather pack housings. **NOTE: CARE MUST BE TAKEN TO INSTALL THE TERMINALS WITH THE CORRECT WEATHER PACK HOUSING. IMPROPER INSTALLATION WILL NOT ALLOW THE TWO HALFS TO PUSH TOGETHER.**

9. Connect the blue wire of the opener motor to the opener switch terminal E. Connect the black wire of the opener motor to the opener switch terminal D.
10. Using 14 gauge red wire, connect the switched +12v of the opener switch to an ignition switch controlled 12-volt positive source. Using 14 gauge black wire, connect the ground terminals of the opener switch to ground.
(See Illustration E.)
11. The switch has an internal light for easy location a night. This lighting terminal will connect to an interior lighting wire for proper dimming function to work. To locate this power source consult a wiring manual for your vehicle.
(See Illustration E.)
12. To complete the installation, reinstall the bottle, and plug the weather pack connectors together. Turn the vehicle on and press the “close” side of the opener control switch for 2 seconds and the opener should completely close the bottle valve. Slowly remove the 4an cap on the bottle nipple. **WARNING NITROUS HAS EXTREMELY COLD PROPERTIES! FROST BITE MAY OCCUR IF CONTACT WITH THE SKIN!** A small amount of nitrous will escape, if the valve is leaking reinstall the cap and cycle the opener open and closed and recheck for leaks.



Illustration D

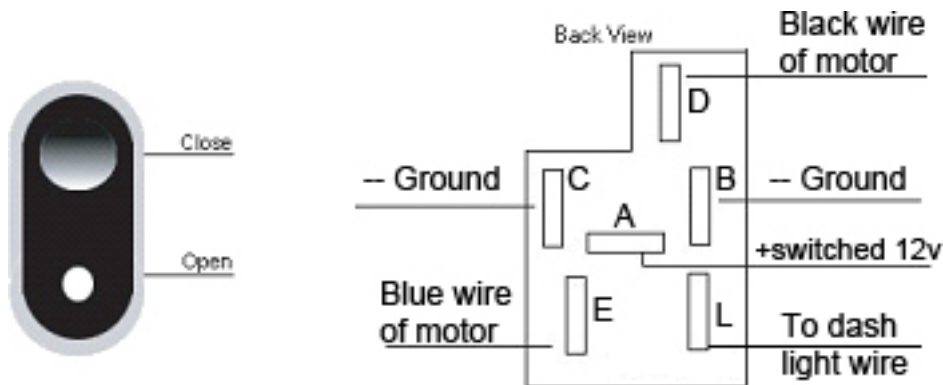

Illustration E



Illustration F