

ADJUSTING THE TETHER LENGTH

(First please read Tether Length / Slack Test Section)

The tether included with the REV2 has 5 sewn slots on each end about 1 inch apart. If you need to adjust your tether length in order to have 2 inches of slack in your slack test, you can do so. Simply remove the tether pin by unscrewing the allen bolt in the front of the device. Remove the shoulder pad for easy access to the bottom side of the tether. Slide the tether to line up the desired slot with the pin, and carefully feed it back into the desired slot.



BE CAREFUL NOT TO PUNCTURE THE TETHER WHEN INSERTING THE PIN!

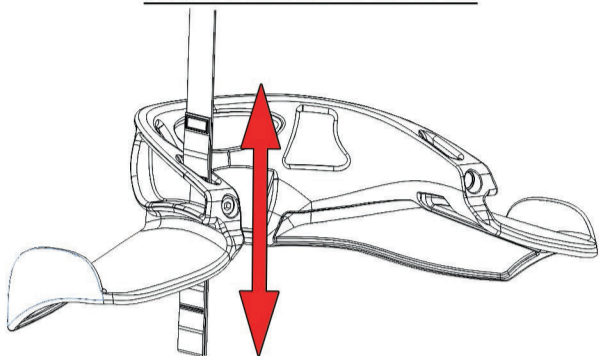

When feeding the pin into the desired slot, take extra care not to puncture the tether, and be sure the pin is aligned with the small hole in the back of the slot. Do not force the pin, it should easily screw in. Watch closely as you insert the pin into the loop to ensure that the pin fits inbetween the tethers, and not outside of them. When tightening the pin, do not overtighten as it will cause damage to the insert. **Tighten to 25 in. lbs.**

RECERTIFICATION

SFI Specification 38.1 requires that Head and Neck Restraint Devices be inspected and recertified after five (5) years from the date of manufacture punched out on the label.

TETHER REPLACEMENT

Tethers will need to be replaced every 5 years. Tethers should also be replaced after a serious accident or if they are showing any signs of wear.

WARRANTY

The NecksGen REV 2 Head and Neck Restraint (HNR) is warranted to be free from defects in material and workmanship for a period of one year from the date of purchase by the original purchaser. The NecksGen REV 2 will be repaired or replaced at the sole discretion of NecksGen. All claims must be submitted to us and accompanied by the device, the original sales receipt, and a statement signed by the purchaser regarding the nature of the defect. This warranty does not apply to damage to the product that is the result of accident, normal wear and tear, or misuse. Any modifications to the product will null and void this warranty.

DISCLAIMER

Please inspect the NecksGen REV 2 before each use. If you believe that the product is not in good working order according to the instructions, stop use immediately and contact NecksGen. As a condition of purchase and/or receipt of the NecksGen REV 2, the user has read and familiarized him/herself with the technical aspects, research and test results relating to the NecksGen REV 2 provided at NecksGen website, and understands and recognizes the nature of the device and the conditions under which it can be used. The user understands and recognizes that the device has not been tested on humans in race or recreational conditions for instrumented impact assessment and that this is a new design. Should you not wish to accept the terms of this warranty or the product prior to its use, please return the product for a refund. There may be a restocking fee. As a condition of purchase and/or receipt of the NecksGen REV 2, the user waives any claims against NecksGen, the inventor, manufacturer, any subcontractor, agent, or distributor. NecksGen, the inventor, manufacturer, any subcontractor, agent, or distributor will under no circumstances be liable to any person for damages, including but not limited to direct injury, indirect injury, bodily or otherwise, including death, that maybe sustained by any person as a result of the use of the NecksGen REV 2. Any alleged defect therein or its alleged failure to afford the protection offered by it or for any consequential loss of profits or damages may arise or for any other reason or from any other circumstance of whatsoever nature. The parties' liability is limited to the actual price paid for the product. The user assumes all risk for the use of the product. As a condition of the purchase/receipt of the product, the user has fully read and understood the manual and installation guide and understands that although the device is designed to help reduce brain, head, and neck injured when worn in conjunction with a helmet with a fixed chin part, there is no guarantee that any injury will be prevented by the use of the device. Each device must be sized for the individual user, and must be of the correct size and fit. This warranty expires upon resale or transfer by the original purchaser. Always attach your helmet correctly according to manufacturer's guidelines, ensure all your safety equipment has not passed its recommended lifespan and travel/race with safety.

NECKSGEN

AHEAD IN NECK PROTECTION

USER MANUAL & INSTALLATION GUIDE

REV2 LITE



MOUNTING THE HELMET HARDWARE

There are three types of helmets, first determine which type you are using, then refer to the appropriate section:

- A: Snell SA2015 / SAH2010 / FIA8858+*
- B: Pre-Drilled Helmet / SA2010
- C: Un-Drilled Helmet

***Snell SA2015/SAH2010/FIA8858+ Identification:**
These helmets will have 6mm threaded inserts bonded into the helmet by the manufacturer.

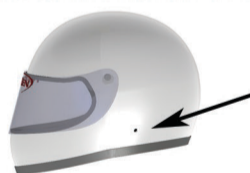

Bonded 6 mm inserts or pre-drilled hole

A: Installation for Snell SA2015, SAH2010 and FIA8858+ Helmets:

Because this type of helmet has the threaded insert bonded inside, you will NOT need the helmet load plate that comes with your helmet hardware.

1. Using the allen key and supplied wrench, unscrew the helmet load plates from both sides and discard.
2. Identify which piece is for the left side, and which is for the right side. The pull tether should hang down.
3. Using the allen key, screw the bolt inside the helmet hardware into each side of the helmet.
4. Align the helmet hardware so that the front points +/- 45 degrees upward toward the helmet visor bolt.
5. Tighten the bolt to 30 inch pounds (3.4nm).

B: Installation for Pre-Drilled Helmets:

1. Verify that the holes are between 3.5 and 6" from the centerline of the rear of the helmet. If so, then proceed to step 2. If not, call NecksGen for help.
2. Using the supplied allen key & wrench, unscrew the helmet load plates from the helmet hardware.
3. Using the wrench to hold the load plate, slide the load plate between the helmet shell and inner lining to line up with your pre-drilled holes.
4. Continue with steps 2-5 from section A above.

C: Un-Drilled Helmets:

1. First you will need to drill the installation holes as per the instructions on the next page.
2. Once you have drilled your helmet, follow the instructions for section "B: Installation for Pre-Drilled Helmets" in the previous section.

MOUNTING THE HELMET HARDWARE

How to Drill Your Helmet

1. Find the center (C) at the back of the helmet.
2. Measure forward 5" to 6" following along the lower edge.
3. Measure & mark 1.5" upward from the bottom edge.
4. Drill a 1/4" (6 mm) hole.
5. Repeat for the other side of the helmet. If your helmet has been pre-drilled and is within a 1" radius of the diagram, it is OK to use these holes.



Installation for Un-Drilled Helmets: Once you have drilled your helmet, follow "Installation for Pre-Drilled Helmets" on previous section.

POSITION OF HARDWARE

It is important to tilt the helmet hardware at 45 degrees relative to the horizontal of the lower edge of the helmet. This will mean that the front edge of the helmet hardware will be pointing upward towards the visor mounting bolt. This angle allows for more free movement of the tethers, which allows the head to turn from left to right.

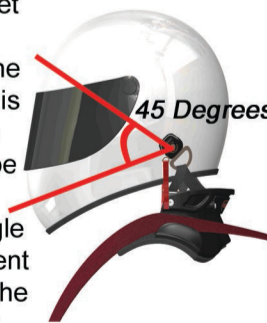

INSTALLATION ON DRILLED HELMETS

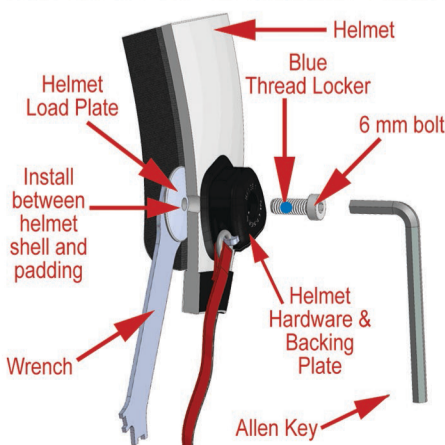

TETHER LENGTH - SLACK TEST

The NecksGen REV 2 has an adjustable length tether to fit most drivers. In order to set the length properly, you must first install the helmet hardware on your helmet, then do a tether slack test.

PINCH HERE TO MEASURE TOTAL TETHER SLACK



TOTAL SLACK IS LENGTH OF GREEN LINE SHOWN HERE FROM ABOVE

The purpose of an HNR is to limit the travel of your head during the course of an impact. It is not intended to hold your head still while driving, or prevent your chin from touching your chest. **Please set the tethers to 2 inches of total slack for best results.**

To perform a tether slack test, it is easiest if you have a helper assist with the measurement. Start by sitting in the vehicle with your REV 2 connected to your helmet and seatbelts snug. Looking straight ahead in your relaxed position, have your helper pull all of the excess tether to one side and pinch it closed. Measure the excess tether taken out. This should be set to 2 inches total. (Or a 1" long pinch). If it isn't, simply remove one or both tether pins from the device and re-insert them into the pocket that allows for the correct slack result. Tighten to 25 in-lb. (see next page for details).

PROPER SEATBELT ALIGNMENT



Find out more about racing gear we have.