



Model #86000



PACKAGE COMPONENTS

Tent bag

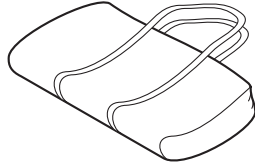

Tent

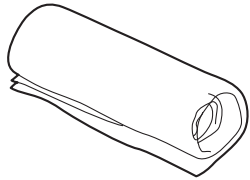

Rain Fly

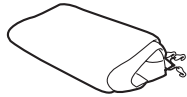

Pole bag

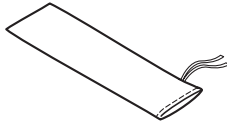

Tent poles (2)

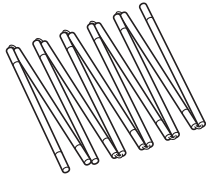

Awning poles (2)

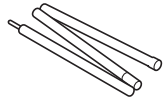

Stake bag

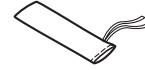

Stakes (18)



Guide ropes (4)



Awning pole caps (2)



Gear loft

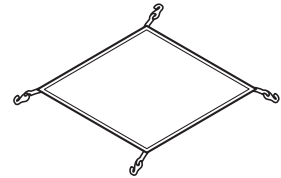

Tent Tie straps (2)



Instructions & Warranty Card

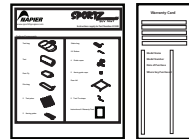

CAUTION

- Do not use candles, matches or open flames of any kind in or near the tent.
- Do not cook inside the tent.
- Build campfires downwind and several metres away from a tent and be sure to fully extinguish campfires before leaving a campsite or before retiring for the night.
- Exercise extreme caution when using fuel-powered lanterns or heaters inside a tent and use battery-operated lanterns whenever possible.
- Do not refuel lamps, heaters or stoves inside a tent.
- Extinguish or turn off all lanterns before going to sleep.
- Do not smoke inside the tent.
- Do not store flammable liquids inside a tent.
- NEVER run the engine when the tent is attached to the vehicle.
- Do not install the tent when the temperature is below 0°/32°F or when your vehicle is wet as it may cause
- damage
- Allow adequate ventilation inside the tent at all times.
- Do not attempt to drive the vehicle with the tent attached

SELECT CAMPSITE

- Select a smooth level campsite clear of rocks, branches and other hard or sharp objects.
- Park the vehicle into the chosen campsite with the vehicle in park and turned off. Apply the parking brake.

Note: The tent may be used as a standard ground tent by simply unzipping the vehicle sleeve.

SETTING UP THE TENT

- 1) Remove the tent from the tent bag and lay it flat on the ground with the vehicle sleeve facing the cargo area of the vehicle. At this point, do not stake the tent to the ground.

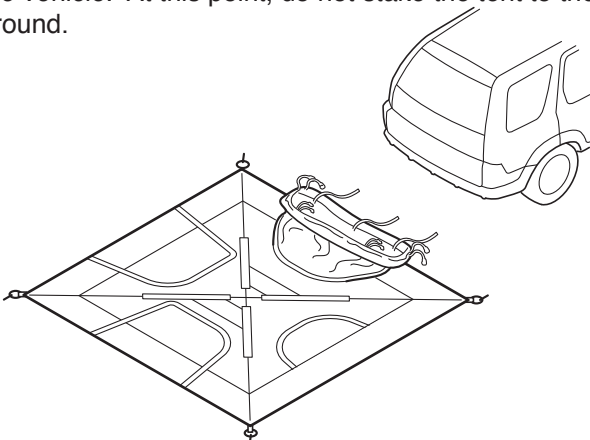

- 2) Assemble the tent poles by unfolding each section.

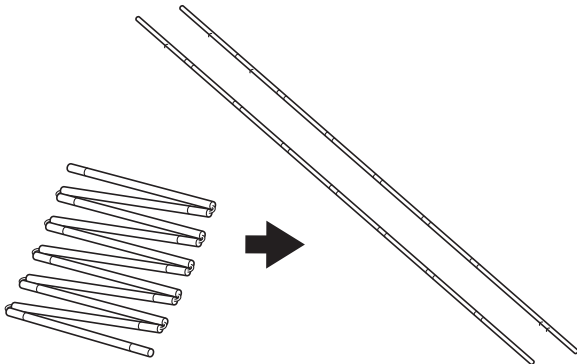

- 3) Slide one pole diagonally, corner to corner going through the 2 pole sleeves in the roof of the tent. Repeat for the other pole.

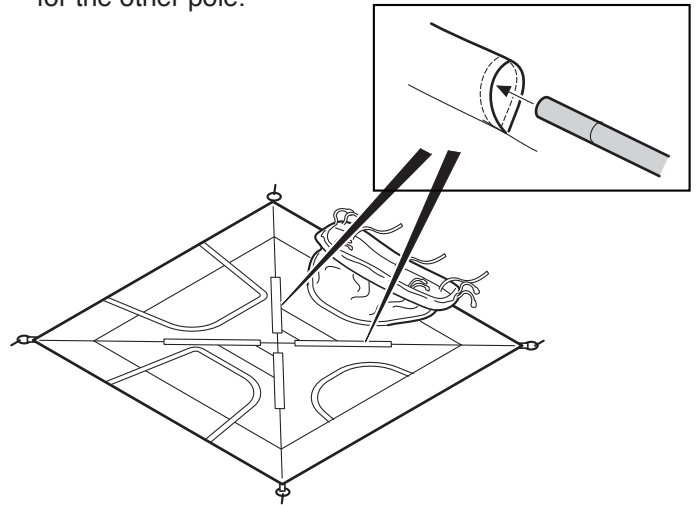

- 4) Take any pole end and insert the pin located on the corner of the tent into the pole end. On the opposite end of the pole, insert the pin into the end of the pole. Repeat these steps for the remaining pole.

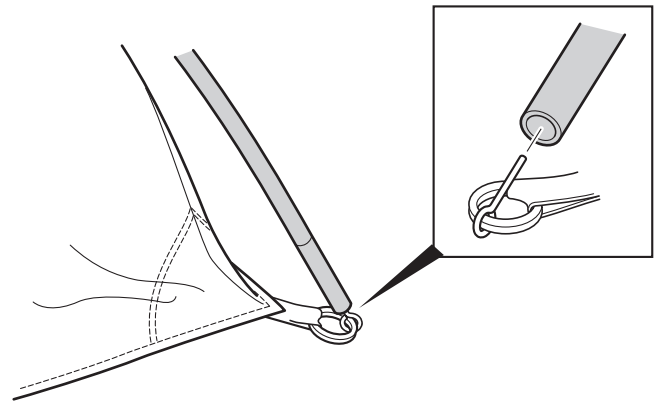

NOTE: The poles may get stuck on the pole sleeves. Do not force the pole, simply go to the sleeve and lead the pole through it.

- 5) Once the tent is standing, attach the plastic clips to the tent pole.

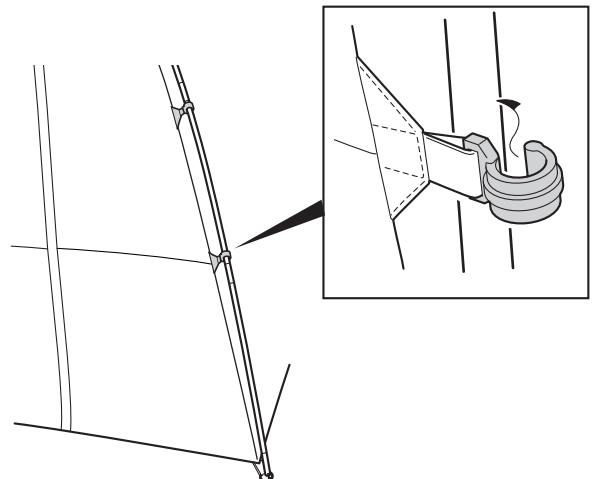

ATTACHING TO YOUR VEHICLE

- 6) From inside the tent, unzip the door and mesh at the vehicle sleeve. Roll up mesh and door and secure with the T-straps.

A) Move the tent towards the cargo area of the vehicle. Slip the sleeve under the bumper and over the roof.

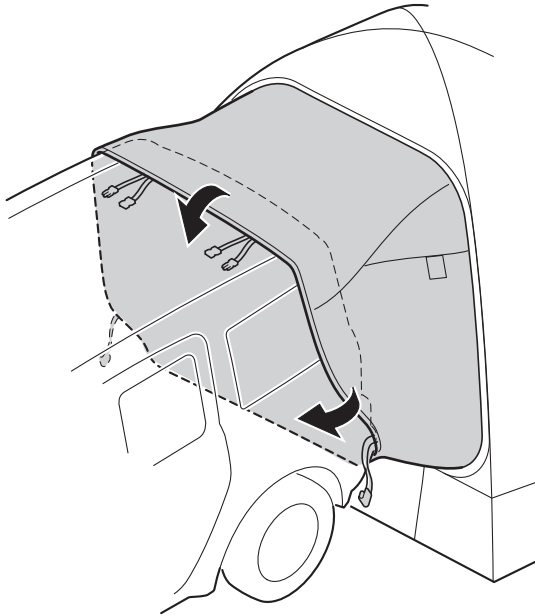

- B) Hook the bottom outside strap to any part of the wheel well and tighten the strap. Repeat on opposite side.

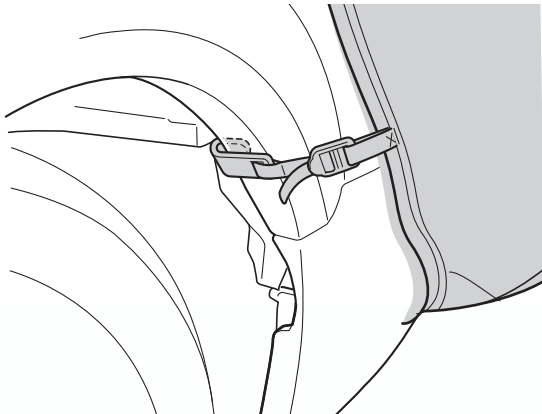

- C) Ensure the exhaust pipe is outside the sleeve.

WARNING: Carbon Monoxide gas is dangerous and can cause unconsciousness or death. Never start or run the vehicle's engine when the tent is attached to the vehicle.

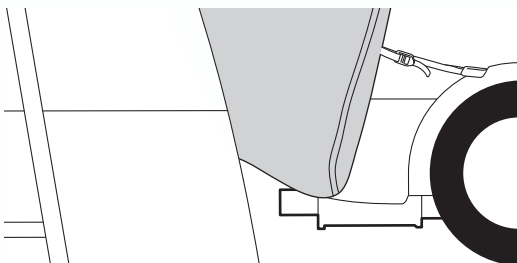

- 7) Attaching the vehicle roof straps.

- A) **WITH A ROOF RACK**, remove the long strap from the female clip. Attach the 2 short straps around the roof rack. Repeat on the opposite side and tighten straps to secure tent.

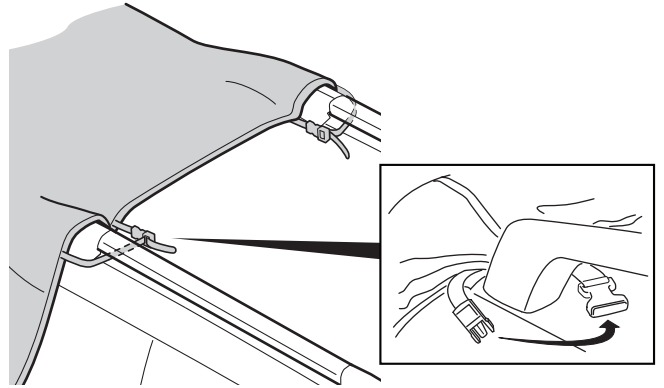

- B) **WITHOUT A ROOF RACK**, extend the long straps to the front of the vehicle. Open the vehicle hood and attach the hooks to the hood hinge or frame. Tighten the straps to secure the tent.

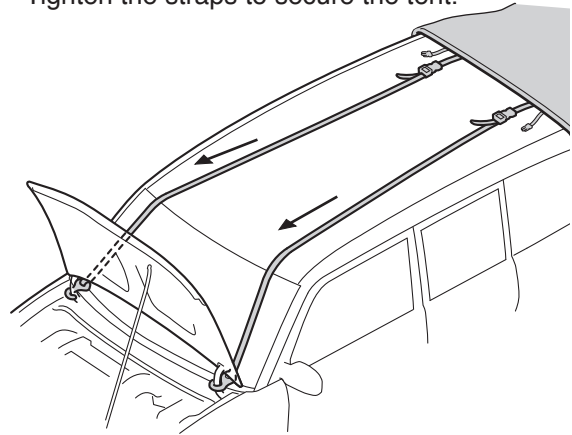

- 8) From inside the tent, attach the center hook to the tailgate latch. For the 2 outer hooks, attach them to the cargo bag hook or to the tailgate latch.

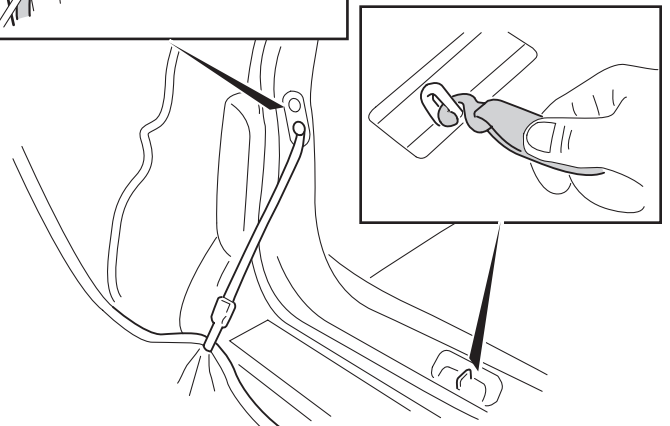
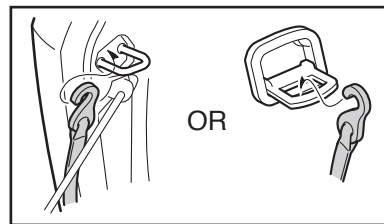

- 9) Stake the tent to the ground through the corner pins and side webbing loops.

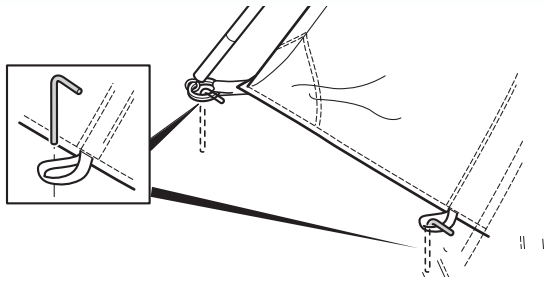

Setting up the Rain Fly & Awning

- 10) Drape the rain fly over the tent. The rain fly side that says "Vehicle Side" goes towards the vehicle. Hook the rain fly to the bottom rings on the tent. Hook the Velcro tab around the pole.



- 11) Stake out the cyclone venting system and the rain fly guide ropes to the ground.

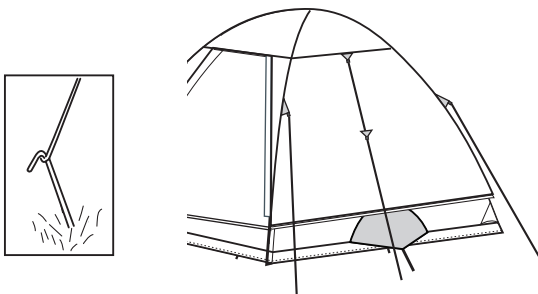

- 12) Assemble awning poles (2) by unfolding each section. Place the pointed end of the pole through the grommet at the corner of the awning. Insert the ring on the guide rope around the point and place the awning cap over the guide rope. Stake the other end to the ground. Adjust length of guide rope. Repeat on other side.

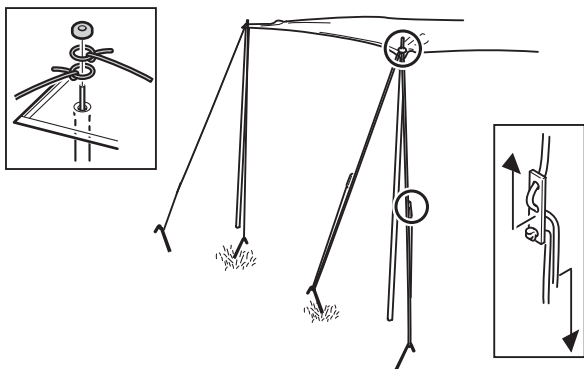

- 13) To install the gear loft, place each corner hook of the gear loft into the loop located on the ceiling of the tent.

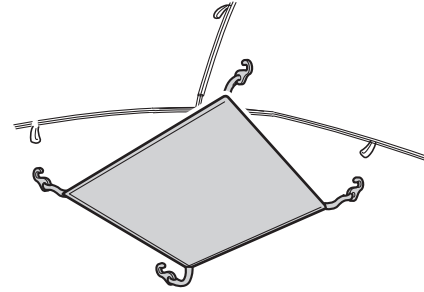

Tent Care Tips

- 1) We recommend you seam seal the seams of your tent prior to use as water may penetrate the needle holes in the fabric. This is common with tents and is not a defect.
- 2) Condensation will form on the inside surface of your tent. It is caused by water vapor from your breath, perspiration or any wet items inside the tent. Water on the inside of the tent is NOT leakage through the tent fabric. To reduce leave door and windows partially open.
- 3) The water resistant coating may wear down over time. It is suggested to spray a water resistant coating onto the tent and rain fly every few years.
- 4) Avoid spraying insect repellent, hair spray, etc., inside or near your tent, as they may be harmful to the tent fabric and cause leakage.
- 5) Do not leave your tent set up in direct sunlight longer than necessary. If left in sunlight for prolonged periods of time, fabric will fade and weaken.
- 6) If zippers stick, lubricate with silicon. Never force a zipper as this will bend and prevent the zipper from closing. Continual use in a sandy environment can cause a slider to erode and fail to close.
- 7) NEVER roll up or pack away a wet/damp tent. This will cause mildew. Make sure your tent is completely dry before storing. Store your tent in a dry place.
- 8) To cleaning, hand wash with a sponge using mild soap. Never use washing machine or detergent.