



PART NUMBER: **D094RKRCC**  
 PRODUCT: **RKR RAILS**  
 APPLICATION: **10-17 RAM**  
**2500/3500**

Parts Included:	Qty
<a href="#">Driver Side Rail</a>	1
Passenger Side Rail	1
<b>Hardware:</b>	
3/8" X 1 Hex Bolts	14
3/8" Washers	14
3/8" Threaded Clips	14



(Shown with Detachable steps part# JPTS32 sold separately)

**PLEASE READ EACH STEP THOROUGHLY BEFORE INSTALLATION**

**Step 1:** Locate the driver's side rail. (See figure below)

**Step 2** Beginning with the driver's side; locate the six sets factory mounting hex holes (3 on each side of the vehicle). These are positioned on the vertical sides of the floor pan beneath the doors, with one set of holes each in the front, middle, and rear of the vehicle cab.



**Step 3:** Using the 3/8" threaded clips, slide two clips in the upper rectangular hole, and align one clip in each hex hole so the clip threads are visible. **Figure 1**

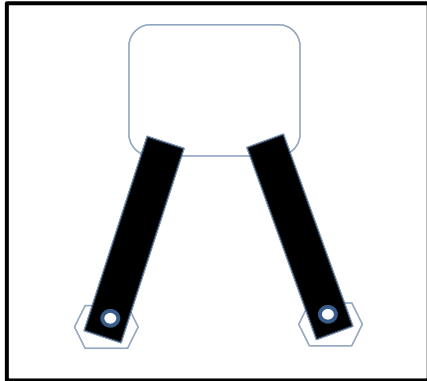

**Figure 1:** 09 - 16 RAM 1500, 2500, 3500, exc. 2014 1500

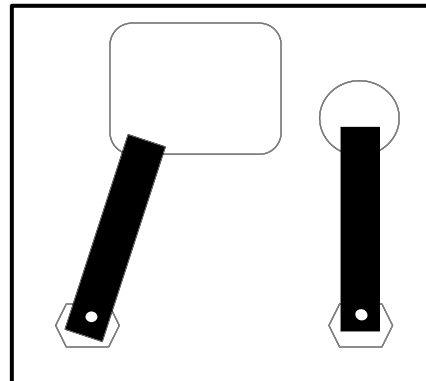

**Figure 2:** 2014 RAM 1500 Quad Cab, rear mounting

**Step 4:** Align the Nerf Step brackets with the three mounting locations on the underside of the vehicle. Start all six 3/8" x 1" hex bolts with washers and hand tighten.

**Step 5:** Using a sharpie, outline the upper "U" shaped mount in the center bracket.

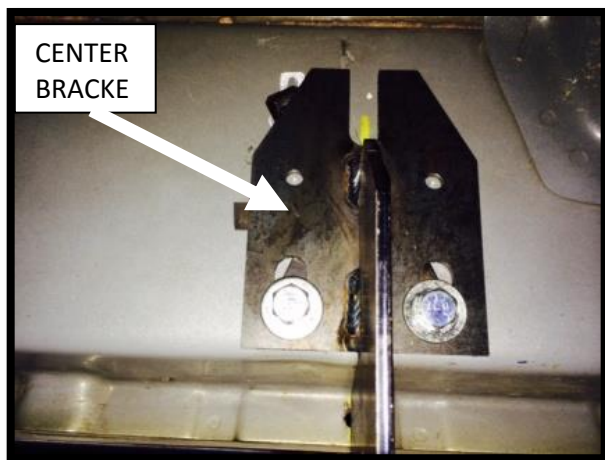



PART NUMBER: **D094RKRC**

PRODUCT: **RKR RAILS**

APPLICATION: **10-17 RAM  
2500/3500**

**Step 5:** Remove Nerf Step and set aside. Next, slide the additional 3/8 threaded clip from the upper rectangle hole and align with the “U” shaped mark from step 5. Make a mark through the threaded part of the clip.

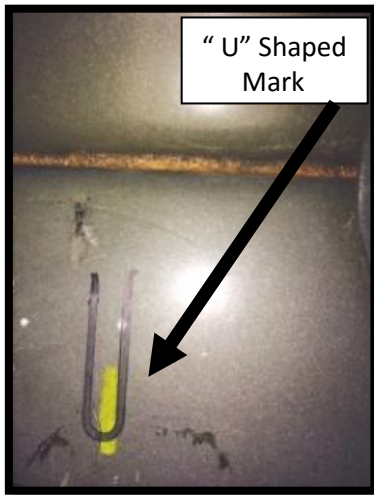

**Step 6:** Remove clip. Use a 1/2” drill bit and drill out the center mark. Slide the 3/8 clip back into position so the threaded part is aligned with the hole.

**Step 7:** Repeat Step 4 with the additional upper clip. Starting with the rear Bracket, raise the Nerf step into position and torque the bolts to 15-20 ft./lbs. Move to the front bracket and torque bolts. Then to the center brackets and torque down bolts. (**NOTE:** There are two additional mounting points in each bracket for a 5/16 self taper or rivet for upper impacts situations. Self taper and rivets not included.)

**Step 8:** Repeat Steps 1-7 for passenger side.

**NOTE:** On 2014 Quad Cab models in the rear mounting location, the hex holes are offset and only the forward mounting hole and clip are used. If desired, the rear clip may be used by cutting a 1" hole directly above the rear hex hole, and level with the lower edge of the upper rectangular as shown by the dotted diagrams in **figure 2**.