



I-SHEET PART NUMBER: INST-00208
 PART NUMBER: TSG15CC-TX
 PRODUCT: TRAIL SLIDER
 APPLICATION: 15-20 COLORADO/CANYON CC

HARDWARE DESCRIPTION		QTY.
HWKT-07768X		
HHCS-07690X	M8 x 1.25 x 30MM HEX HEAD BOLT	16
CLIP-05482X	M8-1.25 X 13/16" BARREL CLIP,	16
FDRW-00736X	M8 FENDER WASHER	16



PARTS INCLUDED		QTY
Driver side slider		1
Passenger side slider		1

TRAIL SLIDER

Step 1: Locate Driver side

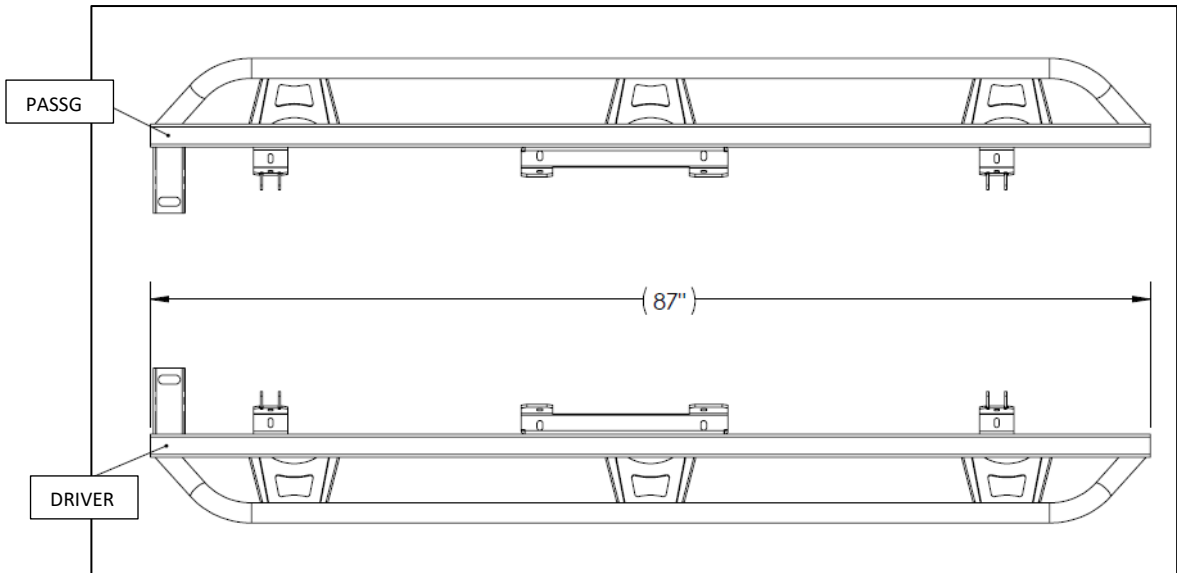

Step 2: Locate the rubber body plugs on the underside of the body. There will be (x4) sections of 2 plugs each. Remove the plugs and discard.

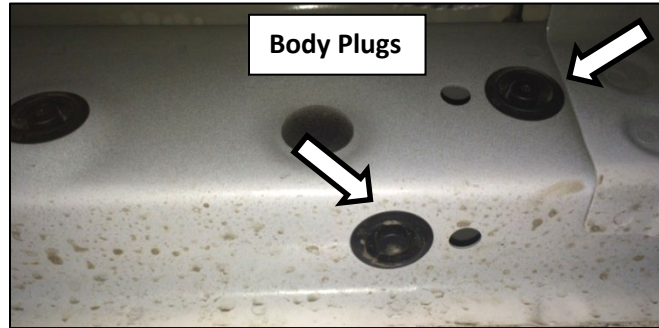

Step 3: Insert one 8mm x 1 ¼' barrel clip into each mounting hole by sliding the clip from the large hole and lining up the threaded part with the smaller hole. Make sure the flat side of the clip faces toward the outside of the body.



Step 4: Next, remove the front and center body bolts and set aside. Do not remove the bushings.

*****NOTE:** *The bell washer from the front body mount will not be re-used. ****

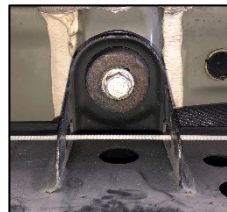

Bell washer will not be re-used



I-SHEET PART NUMBER: INST-00208
PART NUMBER: TSG15CC-TX
PRODUCT: TRAIL SLIDER
APPLICATION: 15-20 COLORADO/CANYON CC

Step 5: With the help of an assistant or with jack stands, lift the trail slider up into place aligning the brackets with the body mounts.

Step 6: Install the middle OE body bolt and leave loose. This will help steady the slider while installing the rest of the hardware.

Step 7: Next, install the front body bolt without the factory bell washer and the (x8) M8x30mm hex bolts.

Step 8: After final adjustment, tighten both body bolts to factory specs and all M8x30mm hex bolts to 15-18 ft-lbs.

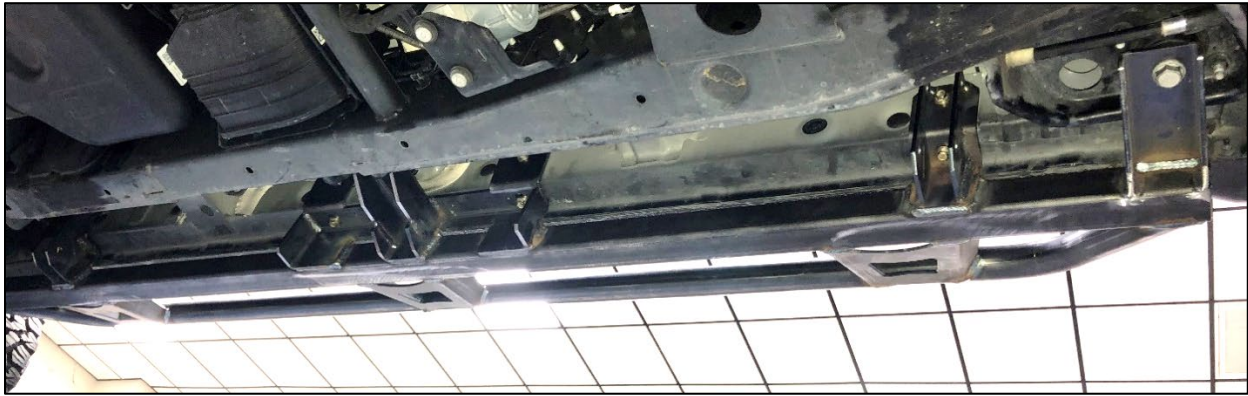

Use supplied M8x30 hex bolts and washers for pinch weld mounts.



Use factory body mount bolts.
** Front mount does not use the factory bell washer **

Step 9: Repeat steps 3-8 for passenger side.