



I-SHEET NUMBER: INST-00139
 PART NUMBER: PRJ1980T-TX
 PRODUCT: ALUMINUM HOOP STEP
 APPLICATION: 2019-20 JEEP JT 4D

PREDATOR PRO



HARDWARE DESCRIPTION	QTY.
# HWKT-05322X	
M8-1.25MM X 30MM HEX CAP SCREW W/WASHER	6
5/16"-18 CLIP-ON NUT, 1/8" PANEL ZINKLAD 1000B	8
5/16"-18 X .75" FLANGE HEAD BOLT, ZINKLAD 1000B	8

PARTS INCLUDED	QTY
Driver side step	1
Passenger side step	1

Step 1: Identify Driver and Passenger side Nerf-step.

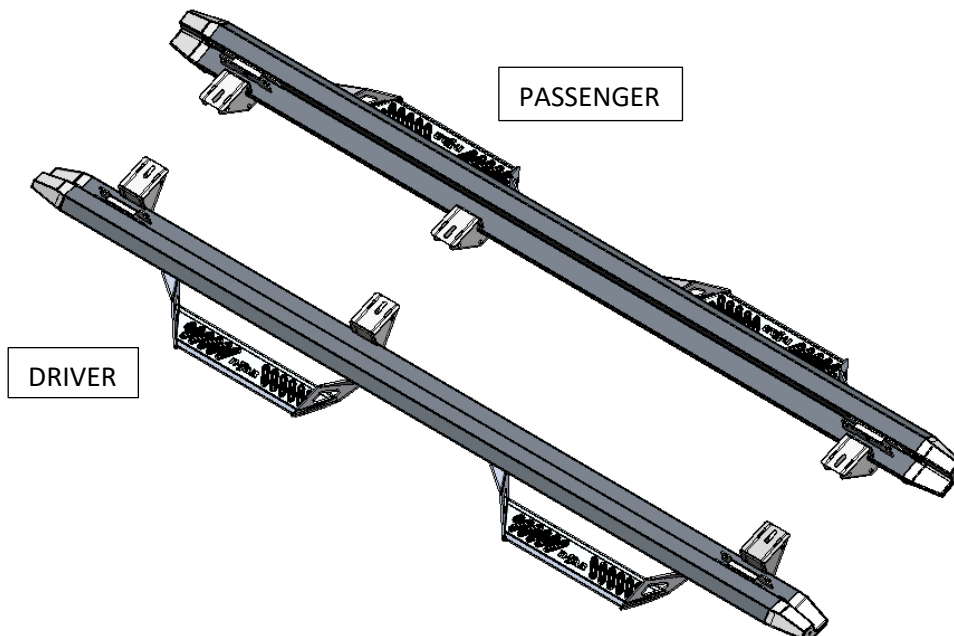

Step.2 Starting with the passenger side step rail, install the supplied (x4) 5/16" snap nuts into the two notches in each front and rear bracket.

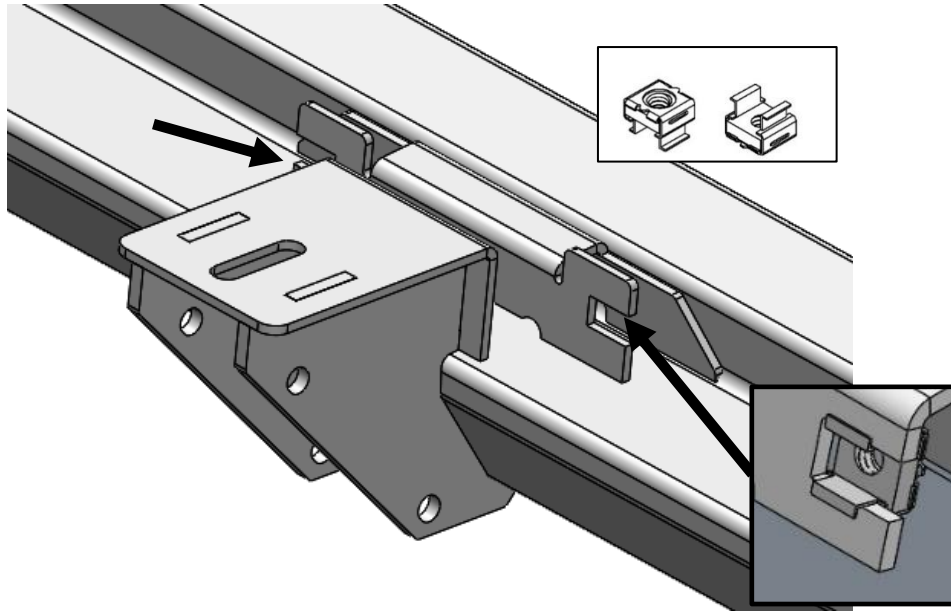

Step.3 Carefully raise step rail up to the pinch weld of the body and align brackets up with the factory mounting locations. **NOTE: Make sure the pinch weld-mounting bracket is on the outside of the body and the cage nuts are aligned with the mounting hole.**

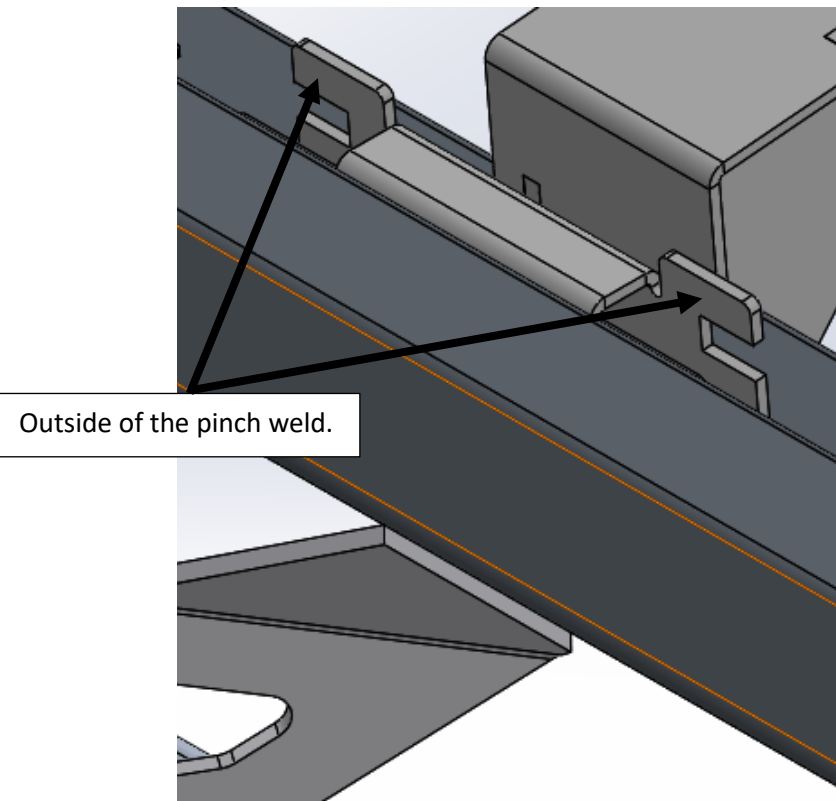



I-SHEET NUMBER: INST-00139
PART NUMBER: PRJ1980T-TX
PRODUCT: **ALUMINUM HOOP STEP**
APPLICATION: **2019-20 JEEP JT 4D**

Step 4 Beginning with the center bracket start one of the supplied M8X30mm Hex bolts and leave loose to help steady the step to install the remaining hardware.



Step 5. Next, go ahead, install the two remaining M8x30mm hex bolts in the upper mounts, and leave loose at this time.

Step. 6 Next, start all (x4) 5/16"x3/4" Flanged hex bolts in the upper bracket mounts through the pinch weld and leave loose.

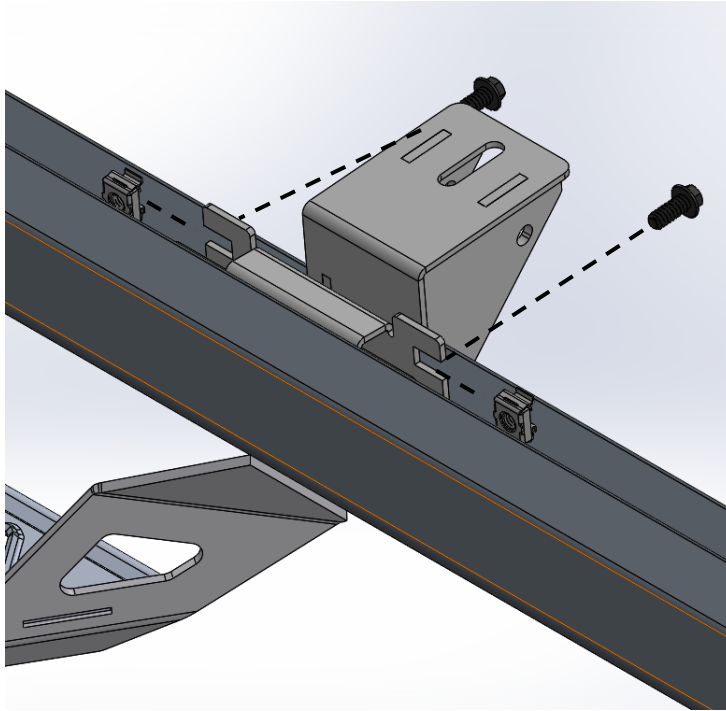

Step. 7 After final positioning, tighten all (x4) 5/16 "x 3/4" hex bolts no more than 6 ft/lbs. torque.

Step. 8 Next, tighten all (x3) upper mounting positions to 17-20 Ft/lbs. torque.

Step.9 Repeat steps 3-6 for passenger side.