



PART NUMBER: PRF9984CC-TX, PRF9971QC-TX  
 PRODUCT: Aluminum Hoop Step  
 APPLICATION: 99-16 F250/F350 CREW CAB  
 99-16 F250/350 SUPER CAB

## PREDATOR PRO



HARDWARE DESCRIPTION	QTY.
# F99 KIT	1
3/8 CLIP SHORT	12
3/8-16X1 1/2 CARRIAGE BOLT ZNC	12
3/8-16 HEX FIN NUT ZNC	12
3/8 USS FLAT WASHER ZNC	12
3/8-16 X 1 HEX C/S GR 5 ZNC	12

**Step 1.** Identify the Driver and Passenger side Step Rail.

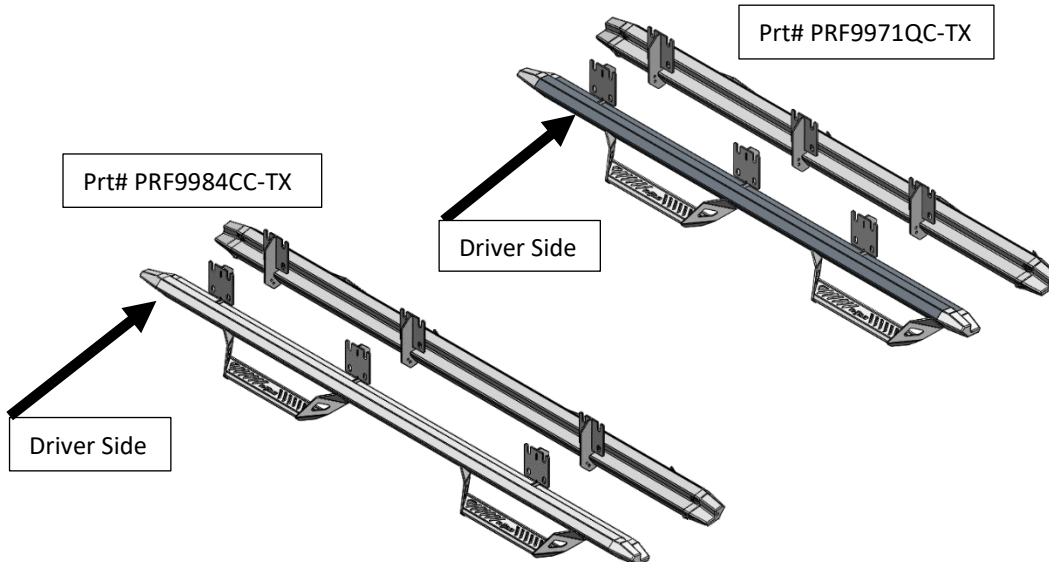

**Step 2** Starting with the Driver side, locate the holes for the upper mounts (x3) and install the supplied (x2) 3/8" clips in each position.

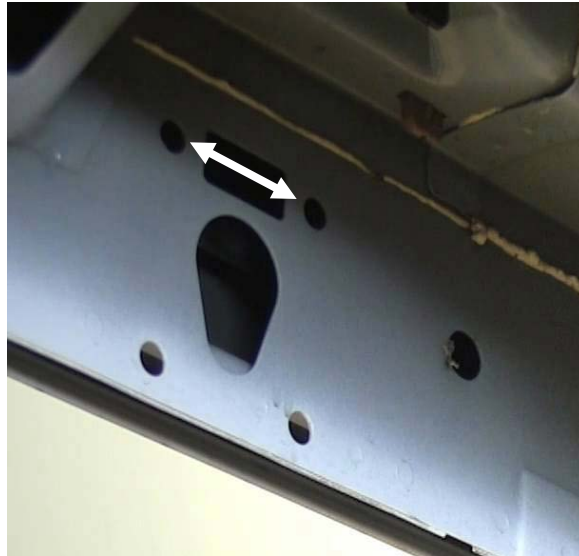

**Step 3** Take the driver side step and carefully raise it up into position and align brackets up to the three mounting positions and start the supplied 3/8" carriage bolts, nuts and washers and hand tighten. **NOTE:** The carriage bolts will start from the outside of the body where the nut and washer will be only visible from the opposite side of the pinch weld.

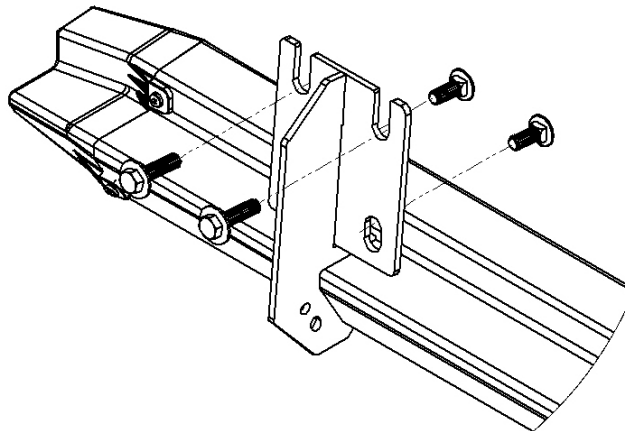

**Step 4** Starting with the rear bracket, carefully push up from the bottom and position the rail snug under the body of the vehicle and tighten only one of the carriage bolts.

**Step 5** Next, move to the front bracket and push from the bottom to level the rail with the pinch weld. Completely tighten the hardware on all three brackets at 17-21 lb/ft of torque.

**Step 6** Repeat steps 2-5 for the passenger side.