



PART NUMBER: PRD0977CC-TX, PRD1577CC-TX
 PRODUCT: Aluminum Hoop Step
 APPLICATION: 09-15.5 Ram 1500 Quad Cab
 15.5-18 Ram 1500 Quad Cab

PREDATOR PRO



HARDWARE DESCRIPTION	QTY.
# D09 KIT	1
3/8 U CLIP LONG LUNUT38	14
3/8 USS FLAT WASHER ZNC	14
3/8-16X1 1/2 HEX C/S GR 5 ZNC	14

HARDWARE DESCRIPTION	QTY.
# D15 KIT	1
3/8 U CLIP LONG LUNUT38	10
3/8 USS FLAT WASHER ZNC	2
3/8-16X1 1/2 HEX C/S GR 5 ZNC	10
M8 FENDER WASHER	12
M8 LOCK WASHER	12
M8X35MM HEX BOLT	12

Step 1: Identify the driver and passenger step rail.

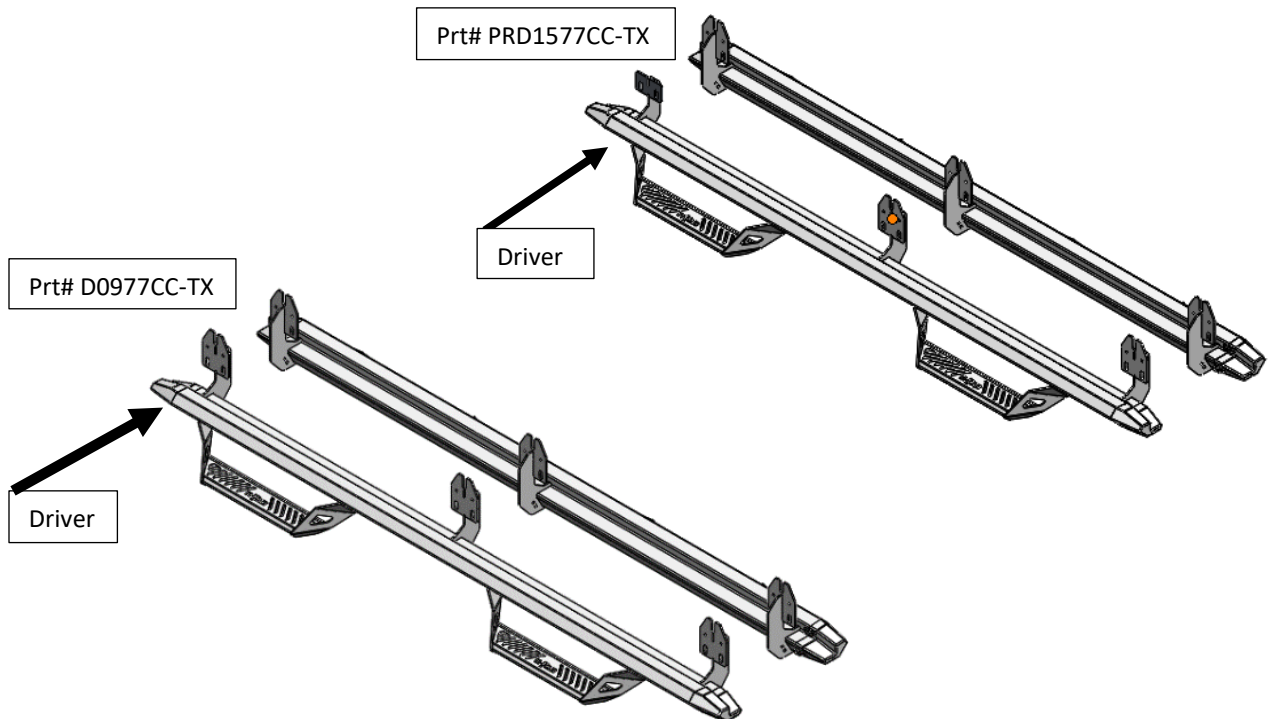

Step 2 Beginning with the driver's side; locate the six sets factory mounting hex holes (3 on each side of the vehicle). These are positioned on the vertical sides of the floor pan beneath the doors, with one set of holes each in the front, middle, and rear of the vehicle cab.

Step 3: Using the 3/8" threaded clips, slide two clips in the upper rectangular hole, and align one clip in each hex hole so the clip threads are visible. **Figure 1**

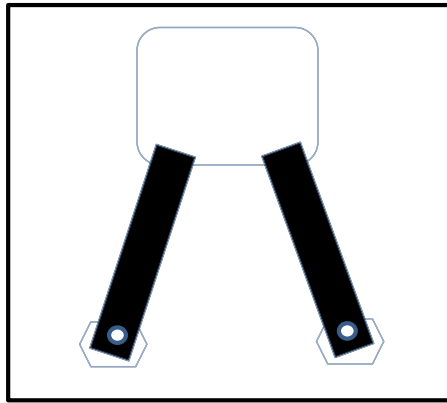

Step 4: Align the Nerf Step brackets with the three mounting locations on the underside of the vehicle. Start all six 3/8" x 1" hex bolts with washers and hand tighten.

Step 5: Using a sharpie, outline the upper "U" shaped mount in the center bracket.

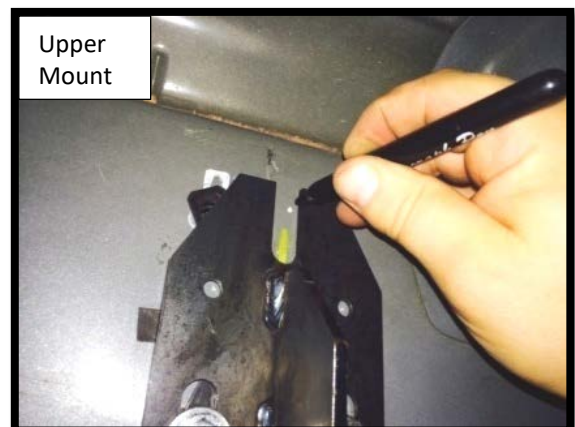
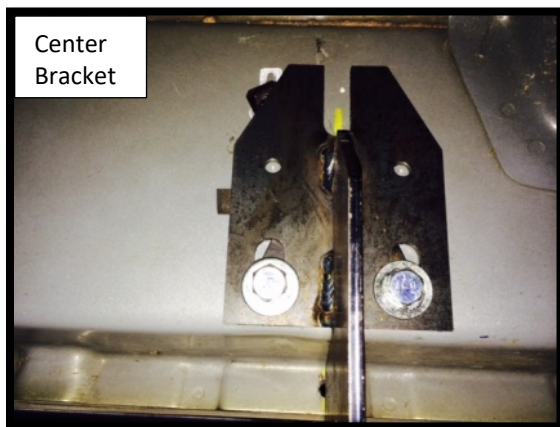



PART NUMBER: PRD0977CC-TX, PRD1577CC-TX
PRODUCT: Aluminum Hoop Step
APPLICATION: 09-15.5 Ram 1500 Quad Cab
15.5-18 Ram 1500 Quad Cab

Step 5: Remove Nerf Step and set aside. Next, slide the additional 3/8 threaded clip from the upper rectangle hole and align with the “U” shaped mark. Make a mark through the threaded part of the clip.



Step 6: Remove clip. Use a 1/2” drill bit and drill out the center mark. Slide the 3/8 clip back into position so the threaded part is aligned with the hole.

Step 7: Repeat Step 4 with the additional upper clip. Starting with the rear Bracket, raise the Nerf step into position and torque the bolts to 15-20 ft./lbs. Move to the front bracket and torque bolts. Then to the center brackets and torque down bolts

Step 8: Repeat Steps 1-7 for passenger side.