



PART NUMBER: PRC1484CC-TX, PRC1584CC-TX
 PRODUCT: Aluminum Hoop Steep
 APPLICATION: 14-18 1500 Chevy Crew Cab

[https://www](https://www.predatorpro.com) **PREDATOR PRO** [rfPb9Zka?dl=0](#)



HARDWARE DESCRIPTION	QTY.
# C14-CC KIT	1
M8 CLIP	2
M8-1.25 HEX FIN NUT DIN 934 CL 8ZNC	6
M8-1.25X25 HX C/S 8.8 ZP DIN933	12
M10 F/W DIN9021 ZNC	18

Step 1. Identify the Driver and Passenger side Step Rail.

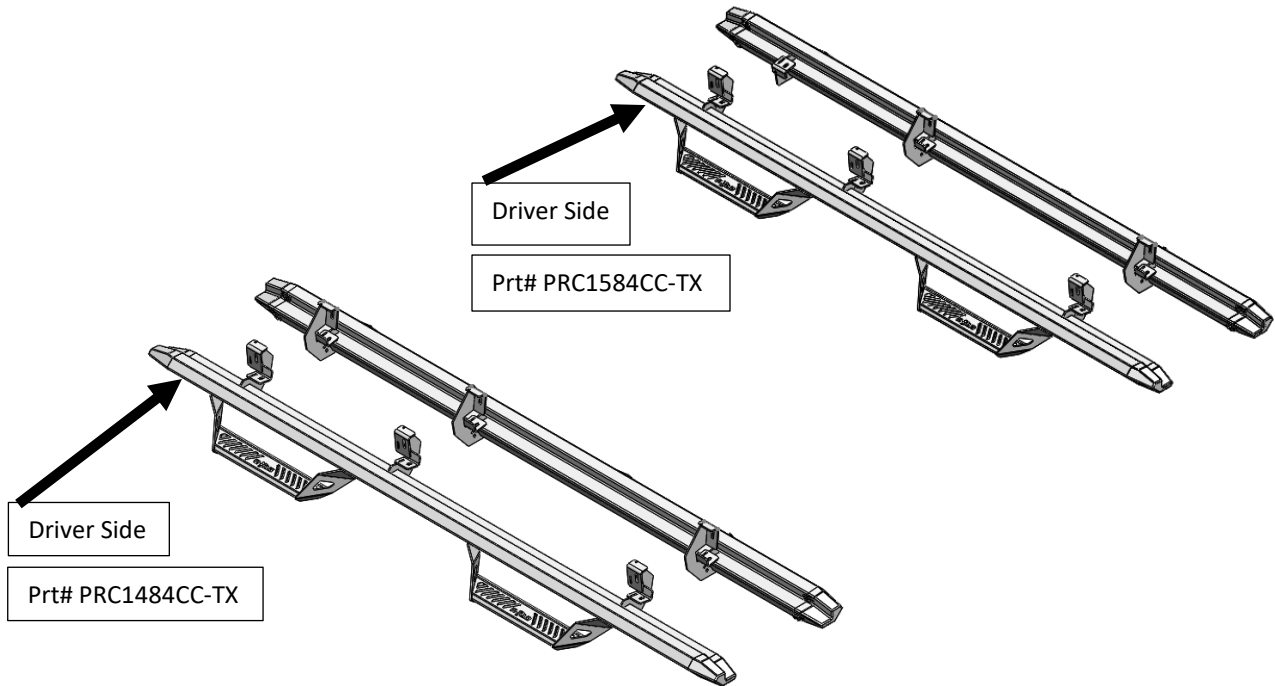

Step 2. With the correct step placed on each side of the vehicle, take note of where the brackets are located. Look under the vehicle and locate the factory supplied mounting positions. **NOTE: Some vehicles require the use of supplied clips and nuts.**

Step 3. If the vehicle requires use of clips, install those now. This requires the removal of a plastic body plug. Use a screwdriver to remove each plug, and install the clips.



Step 4. Align the steps with the mounting holes. Beginning with the middle bracket, use one M8-1.25 bolt and one fender washer for each mounting location and thread the bolts into the mounting holes and leave loose. Continue with the front and rear bracket. **NOTE: Some vehicles require the use of an additional nut and washer for the lower portion of the mounting bracket.**

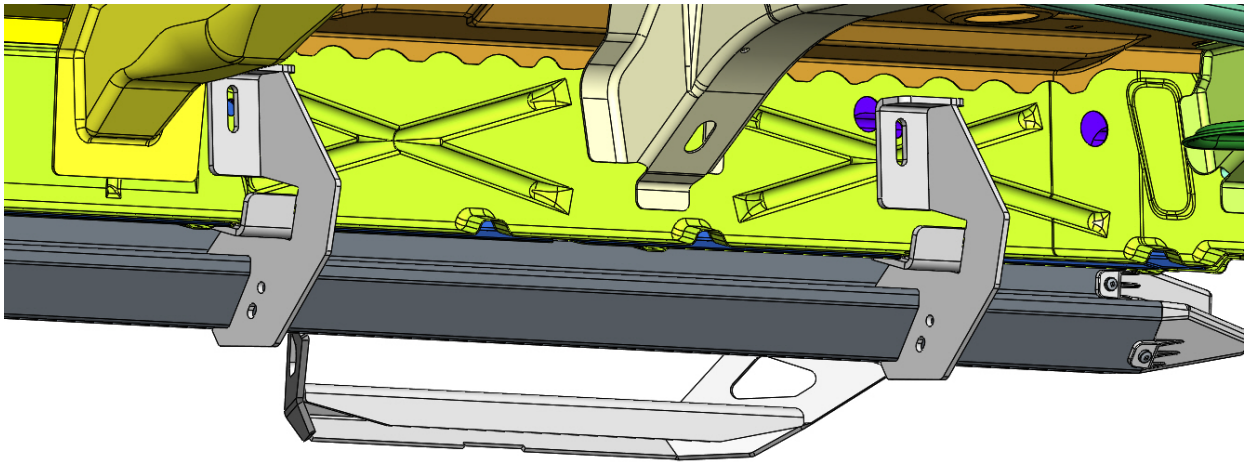

Step 5. After final positioning, begin at the rear bracket and tighten the lower bolt to 15-20 ft. /lb. Continue to the front bracket and then to the center bracket. Next, tighten the upper mounts from front to back at 15-20 ft. /lb.

Step 6. Repeat steps 3-5 for the passenger side. Your install is now complete.