

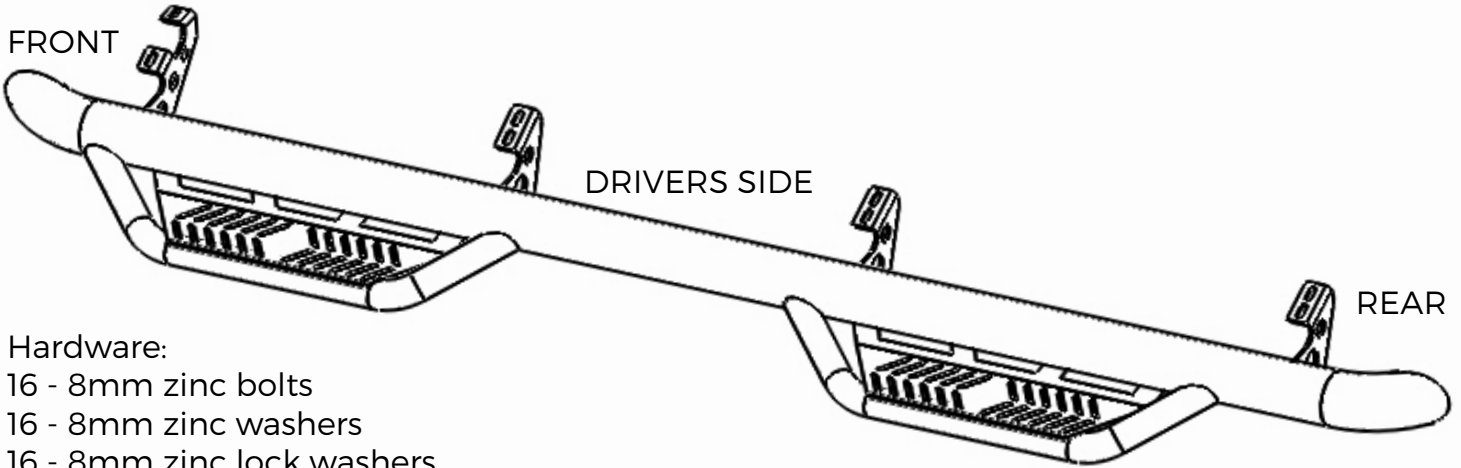

Installation Instructions: N-Fab Podium Nerf-Steps

HPT0786CC-TX / HPT0786CC-SS

TOYOTA
2007-2016
TUNDRA CREW MAX



Hardware:

- 16 - 8mm zinc bolts
- 16 - 8mm zinc washers
- 16 - 8mm zinc lock washers

STEP 1:

Identify the driver and passenger bars. The first bracket has a large notch between the two mounting holes. This bracket goes to the front of the truck.



STEP 2:

Each mounting bracket consist of 2 mounting holes.



STEP 3:

Remove OE boards if equipped then locate mounting holes. Clean any dirt and debris from mounting holes and surface.



STEP 4:

Carefully place HS2 step onto Place. Hand tightening the upper center bolt with washers to hold in place. Best to have a assistant to lift and hold board in place. Now hand tightening remaining mounts bolts.



STEP 5:

Begin tightening bolts in a alternating pattern. **Avoid using power or air tools.** Over tightening could stripe or break the OE threaded inserts.



STEP 6:

Tighten to 20ft lbs torque to secure the board to the truck. Repeat the same procedure to the other side.

