



Installation Instructions: N-Fab Podium Nerf-Steps

HPF9984CC-TX / HPF9984CC-SS

1999-2016

Ford Superduty Crew Cab

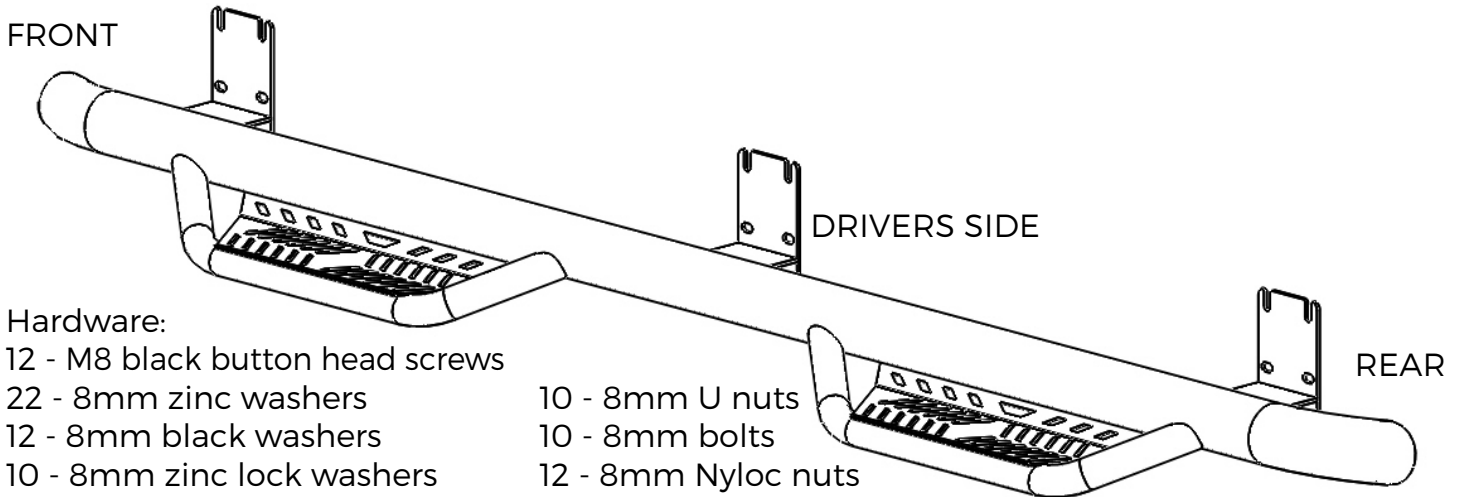

STEP 1:

Identify the driver and passenger bars. The longer section of tube from the bracket to the end goes to the front of the vehicle.

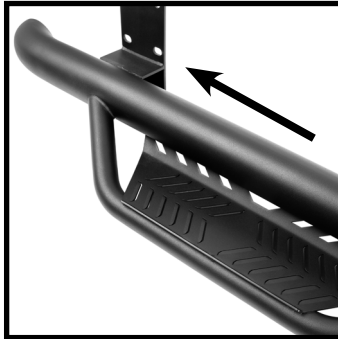

STEP 2:

Each mounting bracket consist of 4 mounting holes. The upper open holes mounts to the body of the truck and the lower holes to the pitch weld.

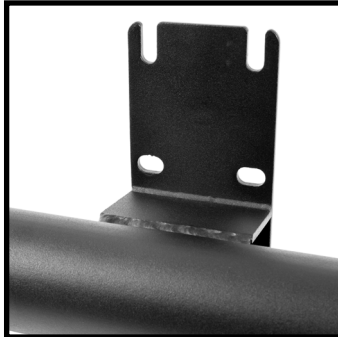

STEP 3:

Insert spring loaded U nuts to the body of the truck. Use two on center and rear mount location. The front mount only uses one U nut.



STEP 4:

Carefully place step into place. Insert black button head bolt and washer through pinch weld hole and secure with locking nut and washer. Best to have a assistant to lift and hold board in place.



STEP 5:

Use bolt, washer and begin hand tightening upper mountings.

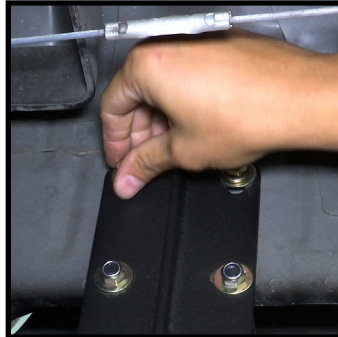

STEP 6:

Begin tightening nuts in a alternating pattern. **Avoid using power or air tools.** Tighten to 20ft lbs torque to secure the board to the truck. Repeat the same procedure to the other side.

