



Installation Instructions: N-Fab Podium Nerf-Steps

HPF1585CC-TX / HPF1585CC-SS

2015-2016

F-150 CREW CAB

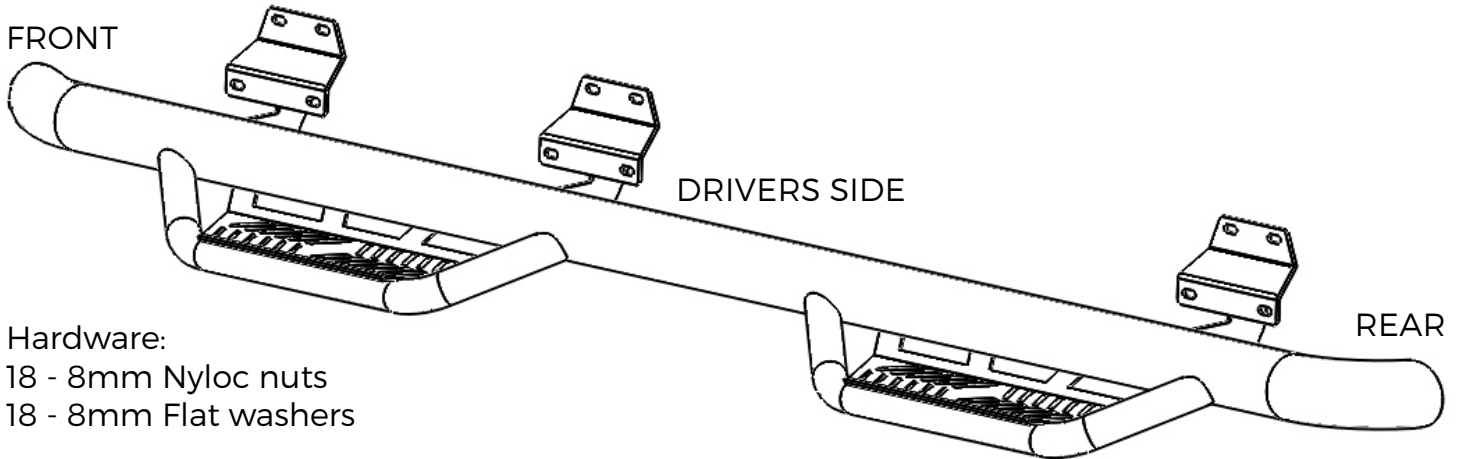

Hardware:
18 - 8mm Nyloc nuts
18 - 8mm Flat washers

STEP 1:

Identify the driver and passenger bars. The center bracket is closer to the front of the truck.

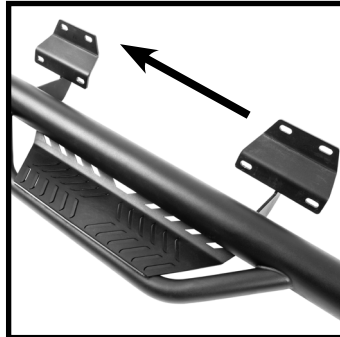

STEP 2:

Each mounting bracket consist of 4 mounting holes, you will use 3 of the holes to mount each bracket to the truck. You will notice the top stud is to the right on some and to the left on others.



STEP 3:

Remove OE boards if equipped then locate mounting studs. Clean any dirt and debris from mounting studs and location.



STEP 4:

Carefully place step onto the studs. Add washers and begin hand tightening nuts. Best to have a assistant to lift and hold board in place.



STEP 5:

Begin tightening nuts in a alternating pattern. **Avoid using power or air tools.** Over tightening could stripe or break the OE studs.



STEP 6:

Tighten to 20ft lbs torque to secure the board to the truck. Repeat the same procedure to the other side.

