



Installation Instructions: N-Fab Podium Nerf-Steps

HPF0989CC-TX / HPF0989CC-SS

FORD
2009-2014
F-150 CREW CAB

FRONT

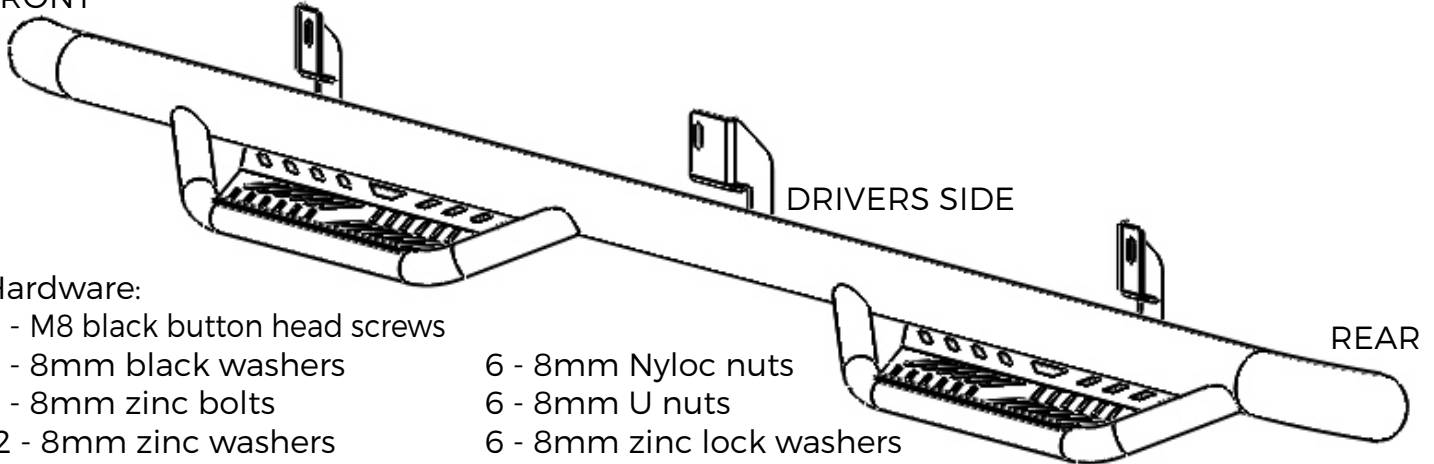

Hardware:

6 - M8 black button head screws

6 - 8mm black washers

6 - 8mm zinc bolts

12 - 8mm zinc washers

6 - 8mm Nyloc nuts

6 - 8mm U nuts

6 - 8mm zinc lock washers

STEP 1:

Identify the driver and passenger bars. The longer section of tube goes to the front of the vehicle.



STEP 2:

Each mounting bracket consist of 2 mounting holes. The upper large hole mounts to the body of the truck and the lower smaller hole to the pinch weld.

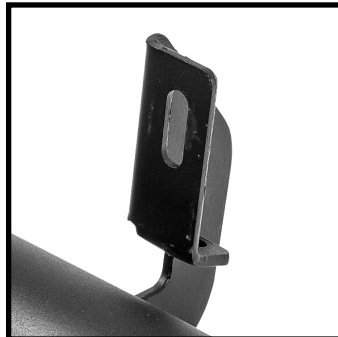

STEP 3:

Insert spring loaded U nuts to the body of the truck. There is three per side. The front and rear clips need to be installed facing the rear of the truck.



STEP 4:

Carefully place step into place. Use bolt, washer and begin hand tightening all 3 upper mountings. Best to have a assistant to lift and hold board in place.



STEP 5:

Insert black button head bolt and washer through pinch weld hole and secure with locking nut and washer.

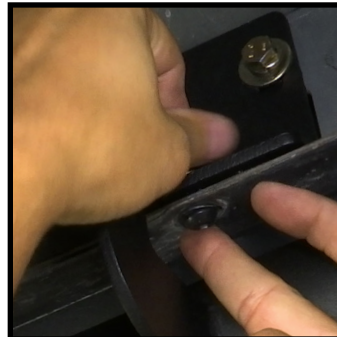

STEP 6:

Avoid using power or air tools. Tighten upper mounts first then pinch weld bolts. Tighten to 20ft lbs torque to secure the board to the truck. Repeat the same procedure to the other side.

