



I-SHEET NUMBER: INST-00001  
 PART NUMBER: C11-CCTX  
 PRODUCT: **Growler Running Board**  
 APPLICATION: **2011-16 CHEVY/GM Diesel 2500/3500 CREW CAB**

HARDWARE DESCRIPTION		QTY.
<b>HWKT-00016X</b>		
CLIP-00643	M8-1.25 X 20MM BARREL U-NUT CLIP	2
HHCS-00647	M8-1.25 X 25MM CLASS 8.8 HEX CAP SCREW	12
FLHB-00688	3/8"-16 X 1" GRADE 5 HEX SERRATED FLANGE BOLT	13
HXNT-00708	M8-1.25 CLASS 8 FINISHED HEX NUT	6
FDRW-00736	M8 FENDER WASHER	18



PARTS INCLUDED	QTY
Running Boards	2
Rocker Panel mounting Brackets	7
Threaded clamp plates	6

# **G**GROWLER

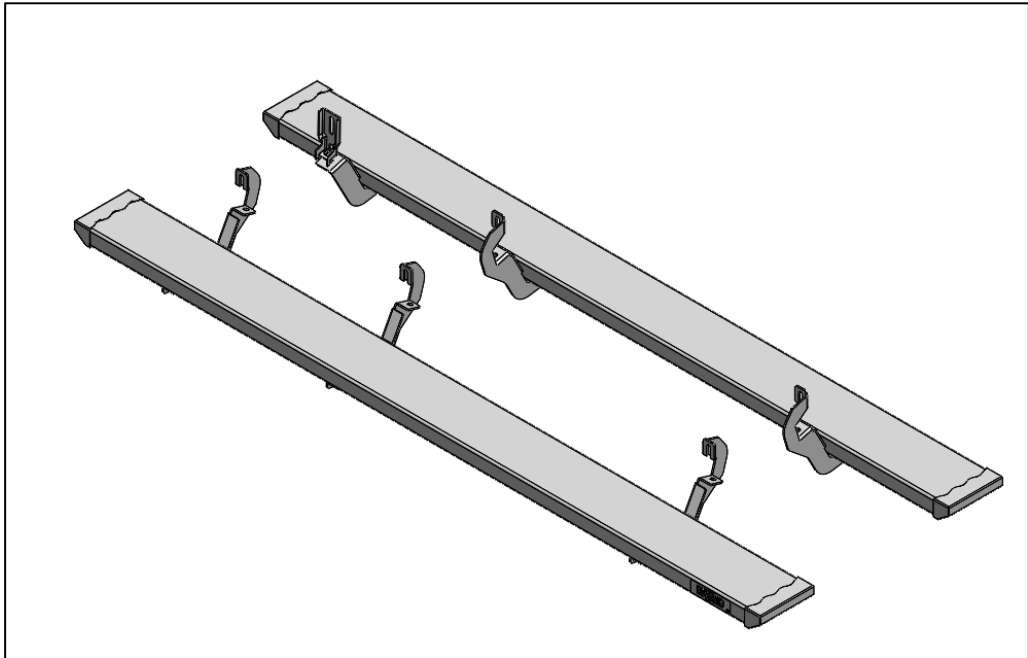

## DRIVER SIDE

**Step 1:** Look on the underside of the body and locate the factory supplied mounting positions.

**NOTE:** Some vehicles require the use of speed clips and nuts, which are supplied with the hardware kit.

**Step 2:** If your vehicle requires the use of the speed clips, install at this time. This requires the removal of a plastic body plug. Using a flat head screwdriver remove the plug and install one of the supplied speed clips.



**Step 3:** Install the brackets to the mounting locations in the body of the vehicle and install hardware. Do not tighten all the way.

**NOTE:** Some vehicles may require the use of additional nuts and washers for the lower portion of the mounting bracket which are supplied in the hardware kit

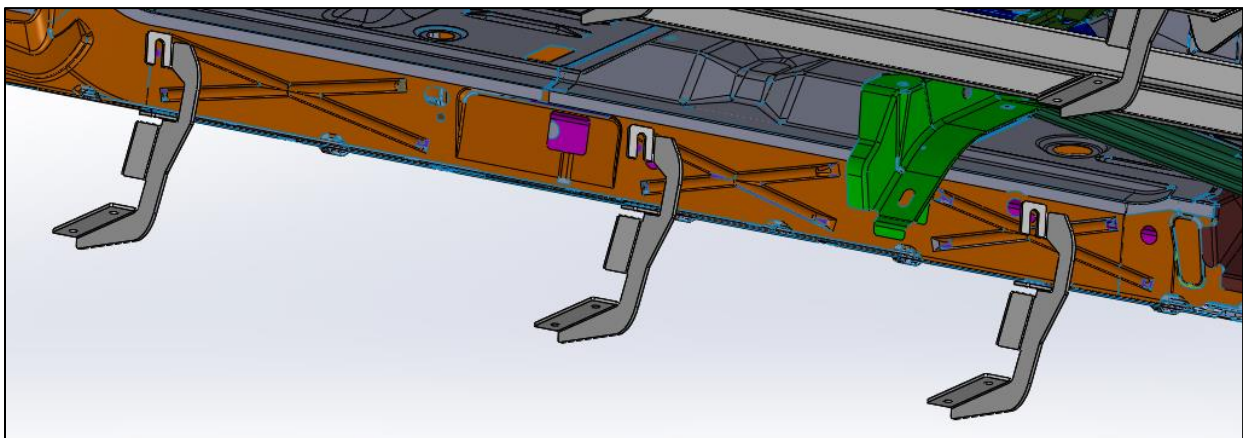



I-SHEET NUMBER: INST-00001  
PART NUMBER: C11-CCTX  
PRODUCT: **Growler Running Board**  
APPLICATION: **2011-16 CHEVY/GM  
Diesel 2500/3500 CREW CAB**

**Step 4:** Set running board along the top of all three brackets and center along the cab.

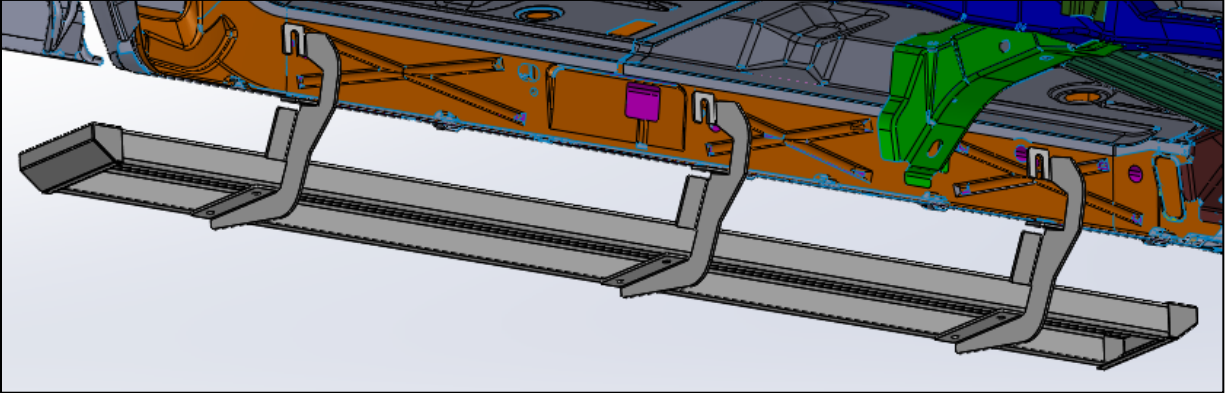

**Step 5:** Insert the supplied threaded brackets (x3) inside the running board lip over the top of each bracket.

**Step 6:** With the supplied 3/8" x 1" hex bolts, secure each mounting location and leave loose.

**Step 7:** After final adjustment, tighten all running board threaded mounts.

**Step 8:** Next, adjust frame brackets so the running board is level with body of the vehicle and tighten all factory-mounting locations.

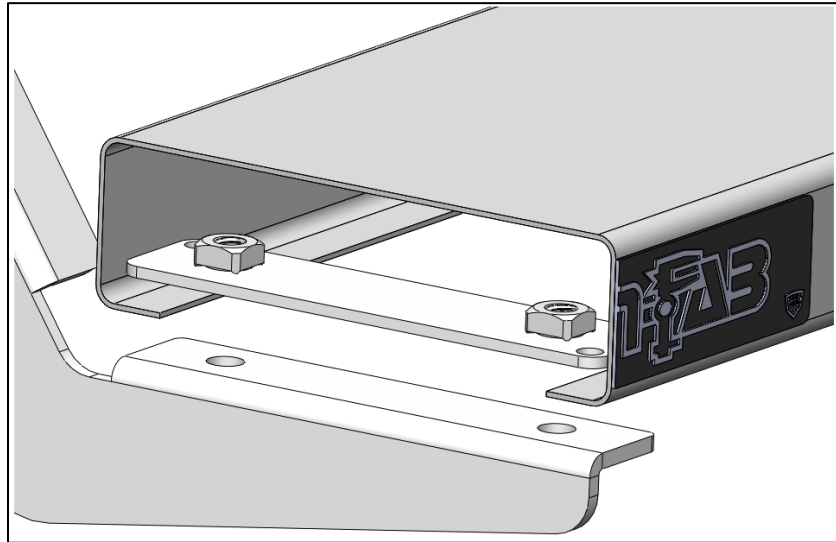

## Passenger side with Def Tank

**Step 1.** Remove the (x3) 13mm bolts, (x2) 10mm bolts and (x2) 10mm nuts that attach the Def tank cover and remove.

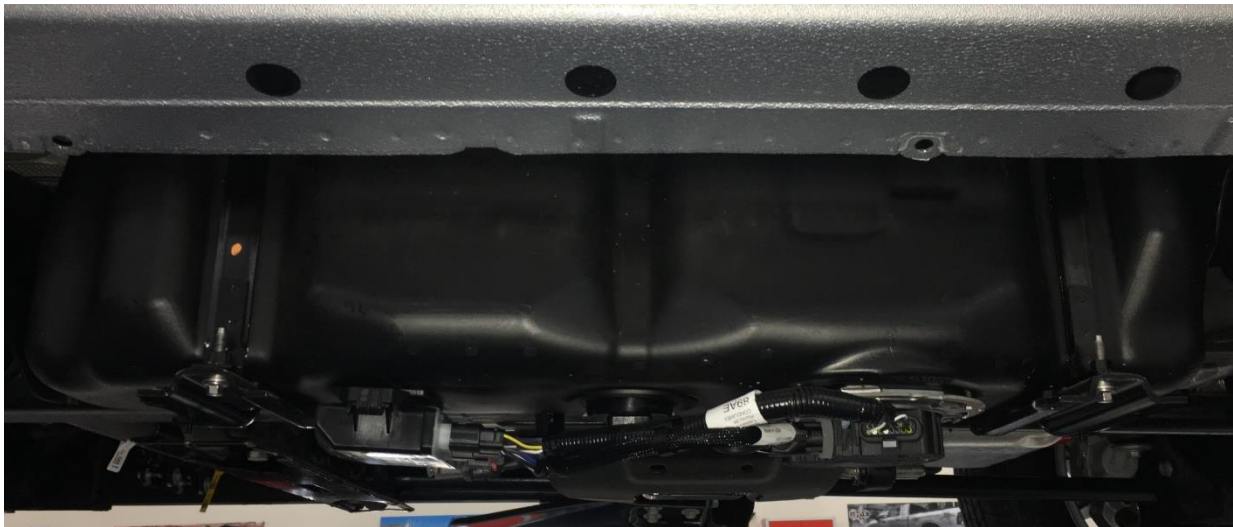



**Step 2:** Feed the short bracket between the body and DEF tank, then align with lower rocker panel mount.

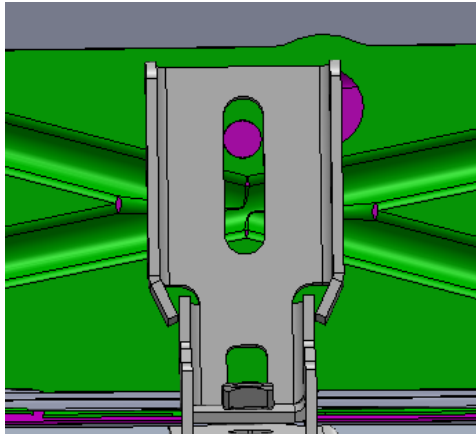

**Step 3:** Using the supplied M8x25mm hex bolts and washers begin hand tightening both upper and lower mounts to the rear two brackets.

**Step 4:** Next, attach the front bracket to the rocker panel bracket that you installed in step 2 and hand tighten.

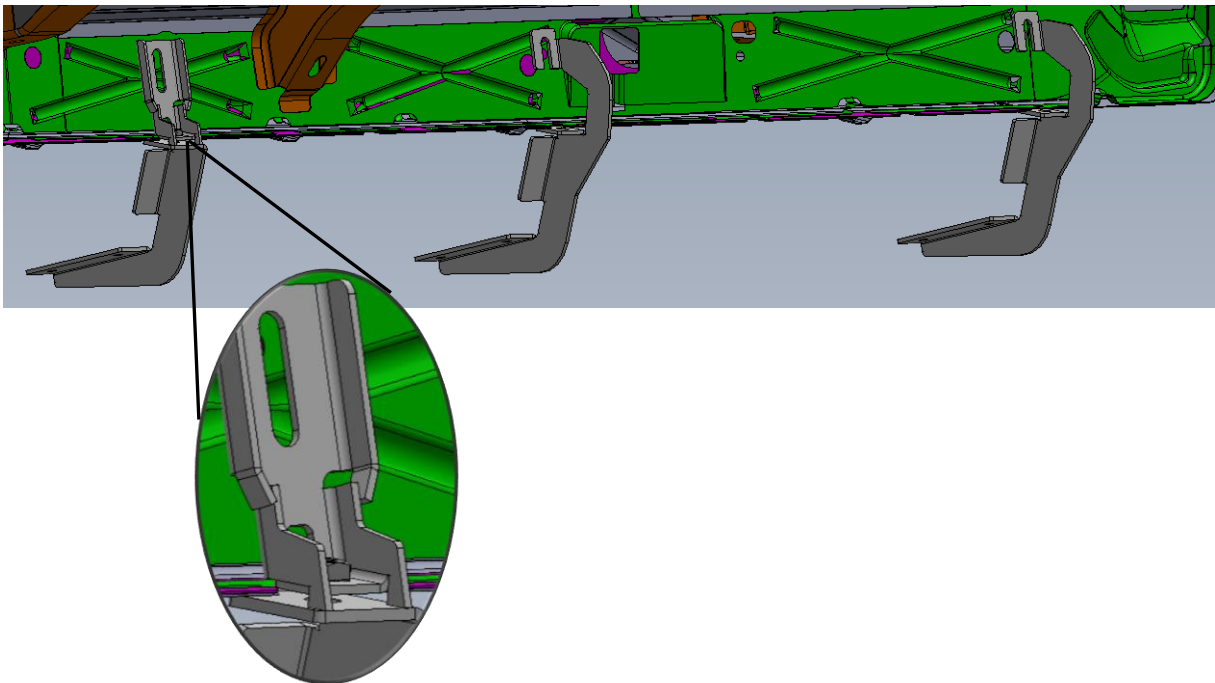

**Step 5:** Set running board along the top of all four brackets and center along the cab.

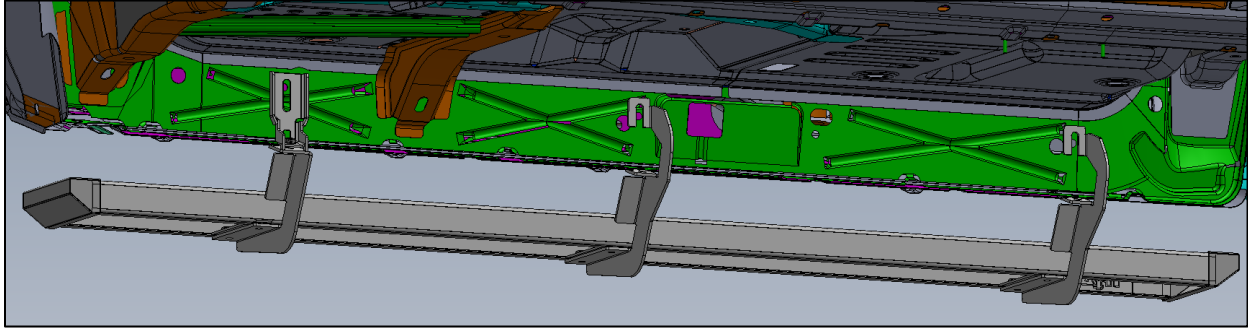

**Step 6:** Insert the supplied threaded brackets (x3) inside the running board lip over the top of each bracket.

**Step 7:** With the supplied 3/8" x 1" hex bolts, secure each mounting location and leave loose.

**Step 8:** After final adjustment, tighten all running board threaded mounts.

**Step 9:** Next, adjust frame brackets so the running board is level with body of the vehicle and tighten all factory-mounting locations.

**Step 10:** Re-install the DEF tank cover that was removed in step 1 and tighten to factory specs.

**Step 11:** Your install for the passenger side is now complete.

