



PART NUMBER: EXT10-TX
 PRODUCT: EYPX HOOP STEP
 APPLICATION: 10-18 TOYOTA 4RUNNER



PARTS INCLUDED	QTY
Step Rail	2
Rocker Panel mounting Brackets	6

HARDWARE DESCRIPTION	QTY.
HWKT-00036X	
M8X30mm Hex cap with washer	12
3/8" x 3/4" carriage bolts	12
3/8" Flanged nuts	12

DO NOT USE IMPACT TOOLS

Step 1: Locate the driver side step rail.

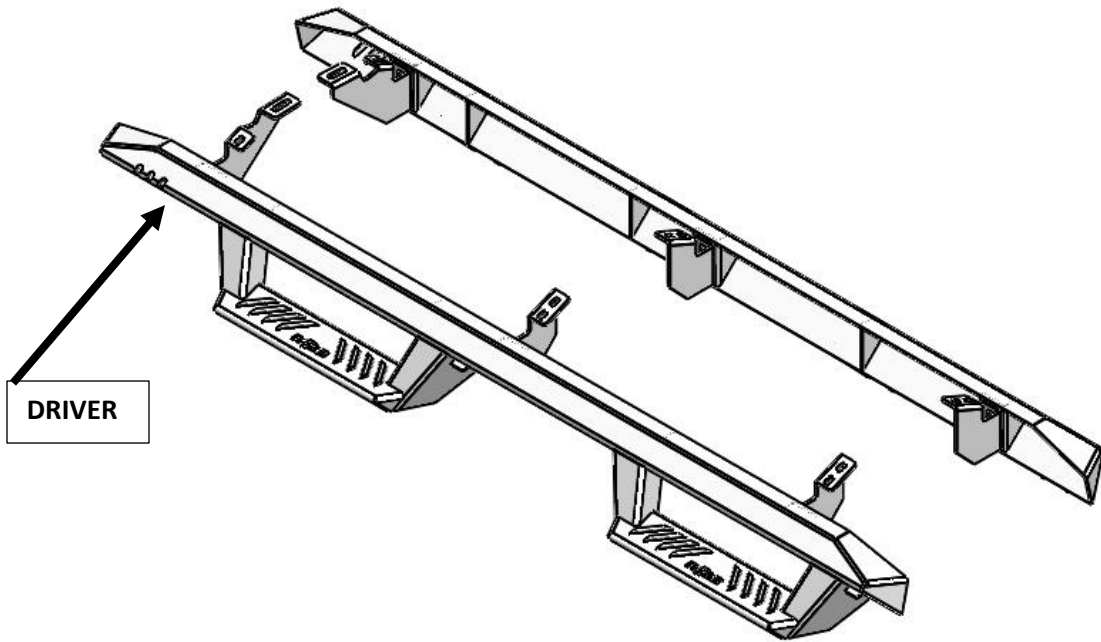

Step 2: Install three rocker panel brackets to the attachments points located on the backside of the channel using the supplied 3/8" x 3/4" carriage bolts and 3/8" flanged nuts. Leave finger tight for now.

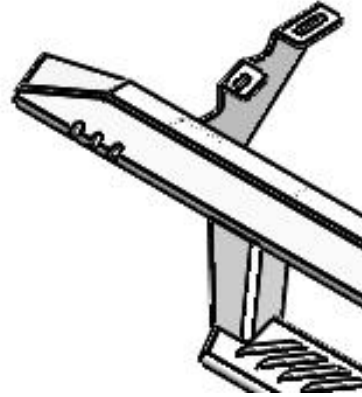
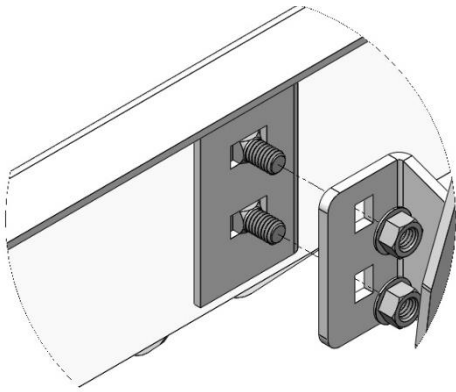

Note: Larger bracket attaches towards the front of the channel

Step 2 Remove any factory hardware and discard.

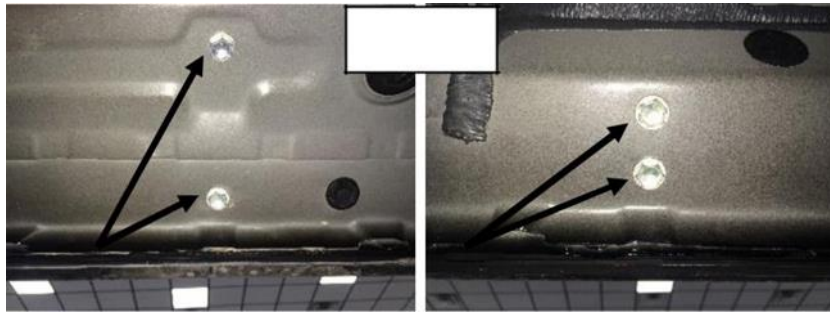

Step 3 Starting with the driver side, position step up to the body of the vehicle and align the brackets up with the factory mounting locations.

Step 4: Position step assembly up to the body of the vehicle and align the brackets up with the factory mounting locations.

Step 5: Beginning with the center bracket, start one of the M8x30mm hex bolts into the factory bolt location and leave loose. Start the second M8x30mm hex bolt in the same bracket and loosely tighten.

Step 6: Start all remaining M8x30mm hex bolts in each bracket and leave loose.



PART NUMBER: **EXT10-TX**
PRODUCT: **EYPX HOOP STEP**
APPLICATION: **10-18 TOYOTA 4RUNNER**

Step 7: Next, adjust the step assembly up/down and front/back to level out the step rail with body panel and then tighten step to brackets at 30 ft. /lbs.

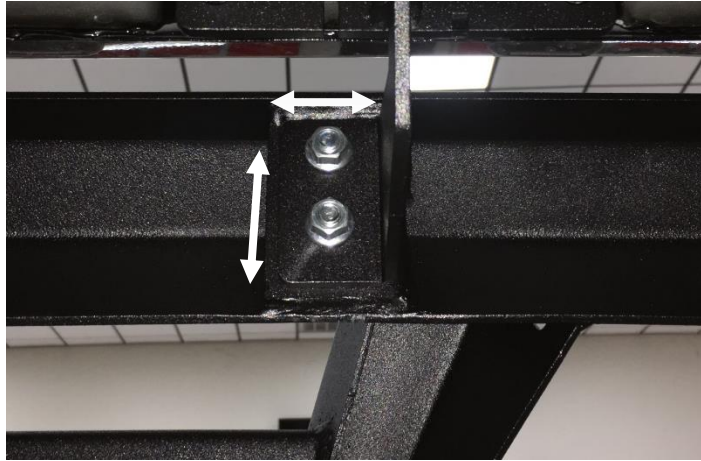

Step 8: After final positioning, start at the rear of the vehicle and tighten the lower portion of the bracket to 15-20 ft/lbs of torque. Continue this until all of the lower have been tighten then move to the top bolt and repeat the process.

Step 9: Repeat steps 2-8 for driver side.