



PART NUMBER: EXJ074-TX  
 PRODUCT: EPYX HOOP STEP  
 APPLICATION: 07-17 JEEP JK 4 DOOR



PARTS INCLUDED	QTY
Step Rail	2
Rocker Panel mounting Brackets	6

HARDWARE DESCRIPTION	QTY.
# HWKT-00041X	
3/8 CLIP SHORT	6
3/8-16 X 1 1/4 C/S GR 5 ZNC	6
3/8 USS FLAT WASHER ZNC	6
M8 F/W DIN 9021 Black ZNC	24
M8-1.25X35 HEX TAP BOLT 8.8 ZINC	6
1/4"-20 x 3/4 hex bolt black zinc	12
1/4" lock washer	12
1/4"-20 HC Nut zinc	12
5/16" USS flat Washer	6

**DO NOT USE IMPACT TOOLS**

**Step 1:** Locate the driver side step rail.

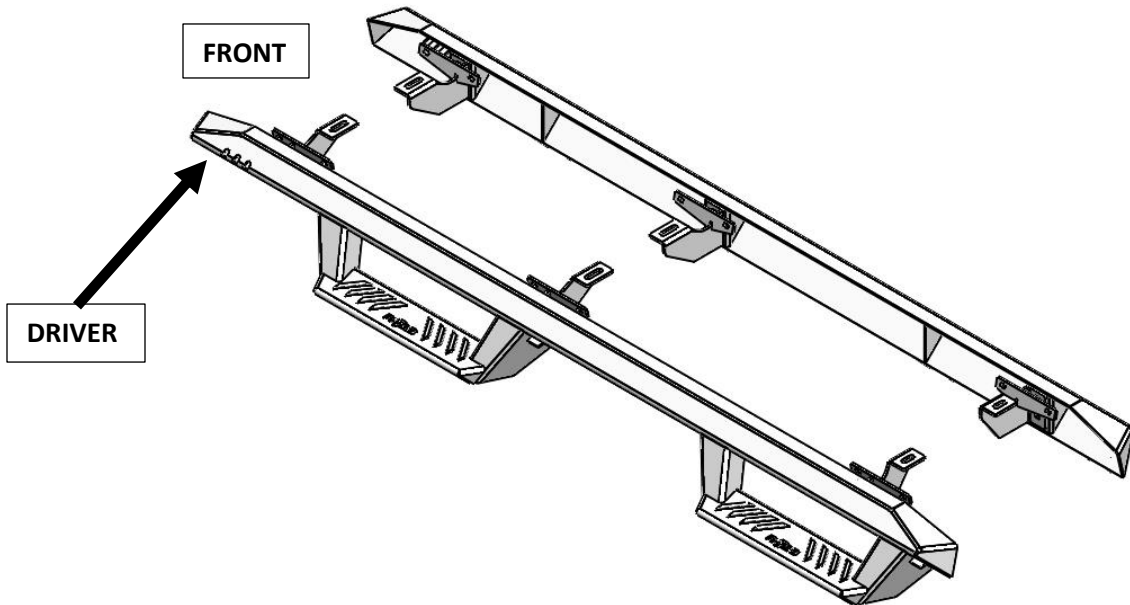

**Step 2:** Install three rocker panel brackets to the attachments points located on the backside of the channel using the supplied 3/8" x 3/4" carriage bolts and 3/8" flanged nuts. Leave finger tight for now.  
**NOTE:** The Driver and Passenger side front bracket will be labeled with a "D" and "P".

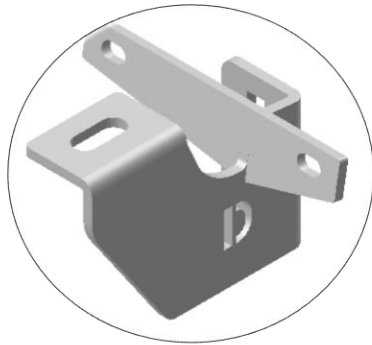
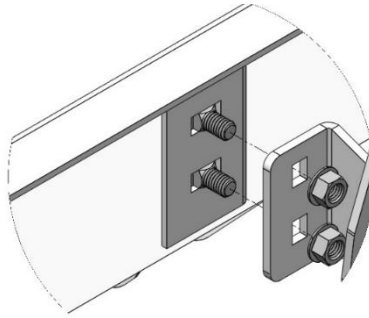

DRIVER FRONT

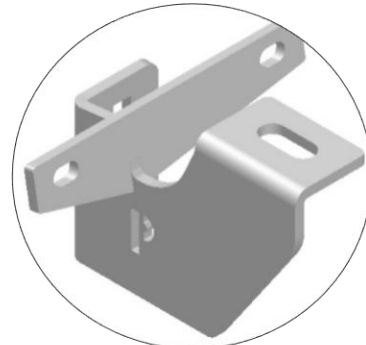

PASSENGER FRONT

**Step 3:** Depending on your cab model, you will have to identify which hardware you will have to use for the upper (3) mounts on the underside of the body. There will either be existing 8mm threaded holes for the M8 x 20mm hex head bolts or open slots for the 3/8" speed clips and 3/8" x 1 1/4" Hex bolts.

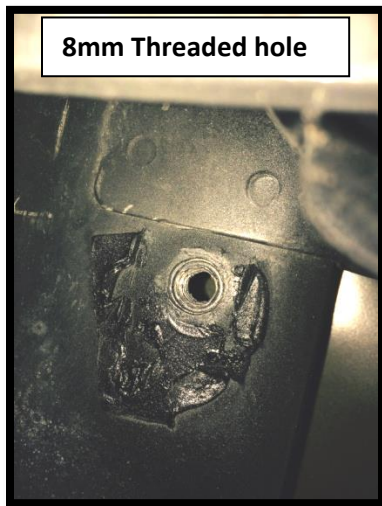



PART NUMBER: EXJ074-TX  
PRODUCT: EPYX HOOP STEP  
APPLICATION: 07-17 JEEP JK 4 DOOR

**Step. 4** Carefully raise step rail up to the pinch weld of the body and align brackets up with the factory mounting locations.

**Step. 5** Depending on your hardware selection made in step 3, fasten the upper mounts and leave loose at this time.



**Step. 6** Next, start all (x6) ¼-20"x 3/4" hex bolts, (x12) M8 flat washers, (x6) 5/16" lock washers and (6) ¼"-20 HC Nut in the pinch weld mounting locations and leave loose for now.



**Step 7:** Next, adjust the step assembly up/down and front/back to level out the step rail with body panel and then tighten step to brackets at 30 ft. /lbs.

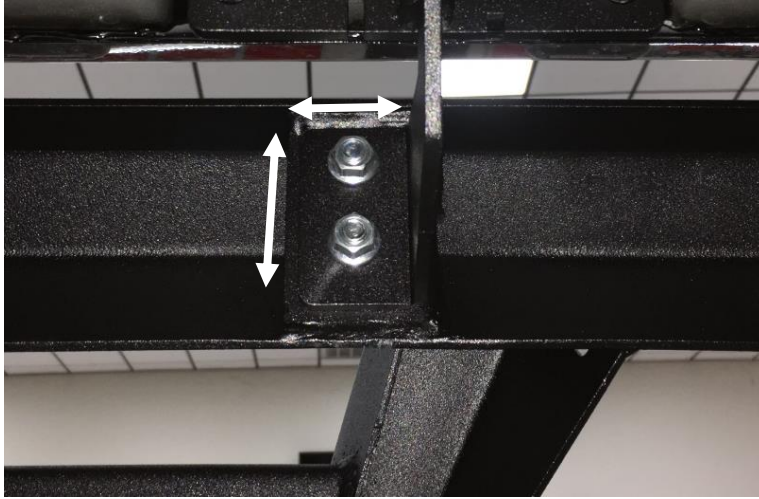

**Step. 8:** After final positioning, completely tighten all (x6)  $\frac{1}{4}$ "-20 x  $\frac{3}{4}$ " in the pinch weld attachment.

**Step. 9:** Next, tighten all (x3) upper body mount positions to 17-20 Ft/lbs. torque.

**Step. 10:** Repeat steps 2-9 for passenger side.