



I-SHEET PART NUMBER: INST-00114
 PART NUMBER: EXF19CC-TX
 PRODUCT: EPYX
 APPLICATION: 2019 + FORD RANGER
 CREW CAB



PARTS INCLUDED	QTY
Step Rail	2
Rocker Panel mounting Brackets	6

HARDWARE DESCRIPTION	QTY.
HWKT-04602X	
M10x25mm HEX FLANGED BOLT	12
3/8" x 3/4" carriage bolts	12
3/8" Flanged nuts	12

DO NOT USE IMPACT TOOLS

Step 1. Identify the Driver and Passenger side Step Rail.

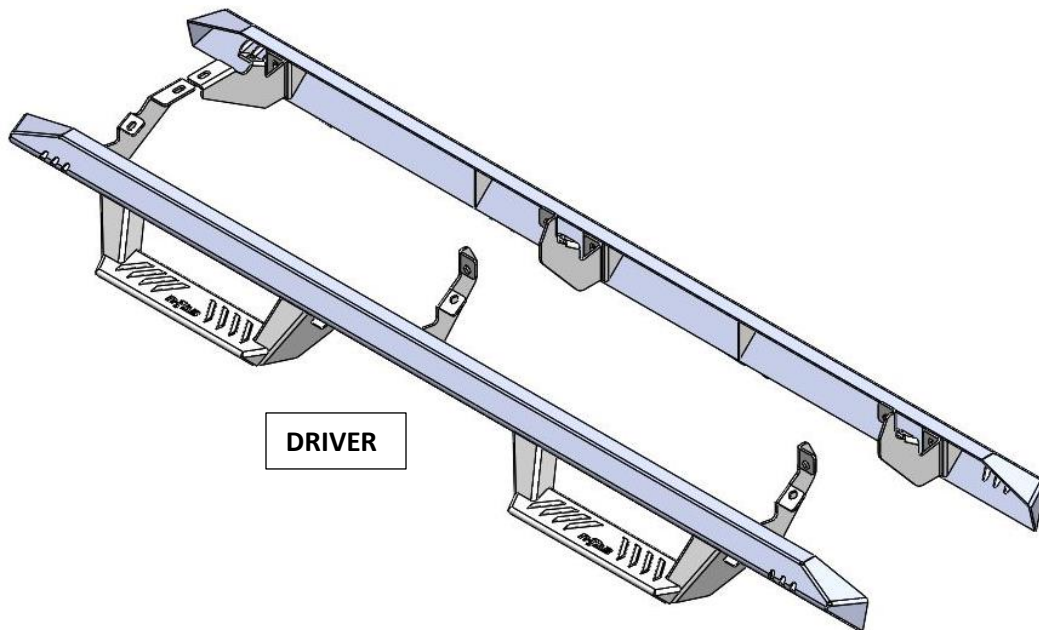

Step 2: Install three rocker panel brackets to the attachments points located on the backside of the channel using the supplied 3/8" x 3/4" carriage bolts and 3/8" flanged nuts. Leave finger tight for now.

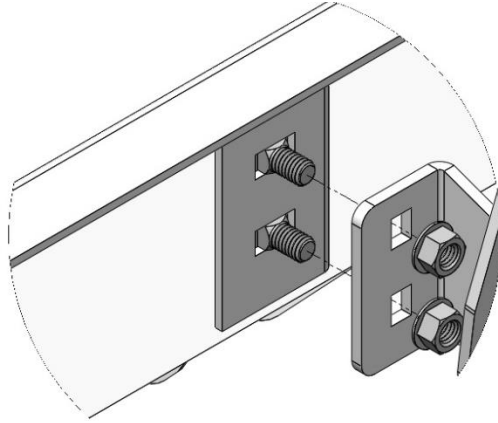

NOTE: Larger bracket will attach towards the front of step rail in the first position.

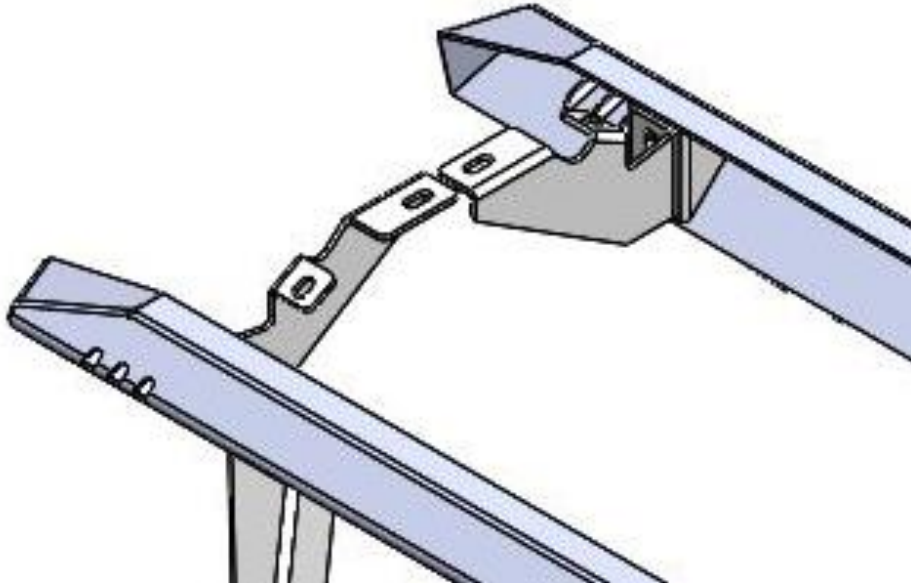



I-SHEET PART NUMBER: INST-00114
PART NUMBER: EXF19CC-TX
PRODUCT: EPYX
APPLICATION: 2019 + FORD RANGER
CREW CAB

STEP 3: Remove any factory running boards or hardware and discard.
STEP 4: Clean/tap the three factory threaded mounting locations.



STEP 5: Carefully place step into place and loosely fasten using the supplied M10X25mm hardware.

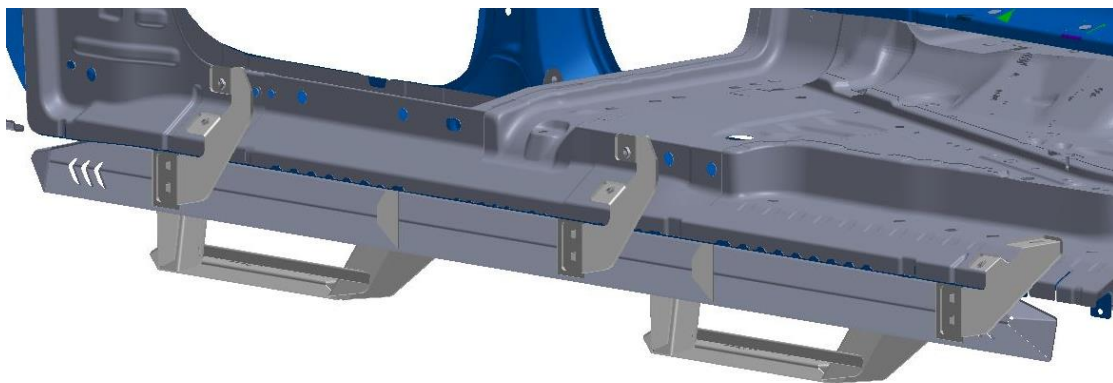

Step 6: Next, adjust the step assembly up/down and front/back to level out the step rail with body panel and then tighten step to brackets at 20 ft. /lbs.

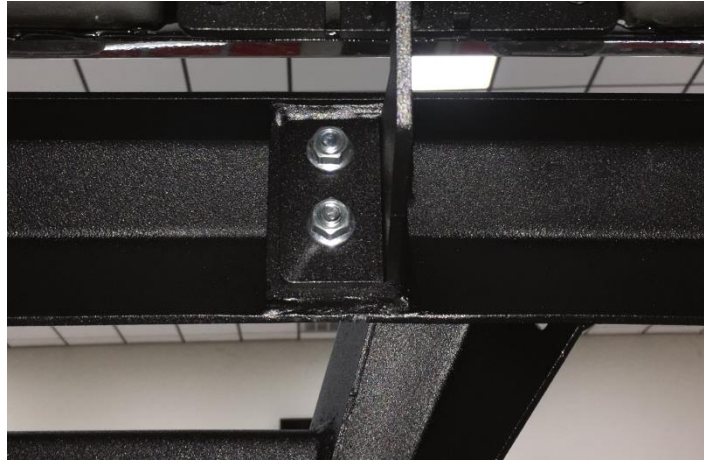

Step 7: Adjust the step rail to where you have approximately $\frac{1}{4}$ " gap between the body of the vehicle and the top of the rail.



Step 8: After final adjustment, tighten all rocker panel brackets to 30 ft./lbs.

Step 9: Re-peat steps 3-8 for passenger side.