



I-SHEET PART NUMBER: INST-00154
 PART NUMBER: **EXD20CC-TX, EXD20MC-TX**
 PRODUCT: **EYPX HOOP STEP**
 APPLICATION: **RAM 2500/3500 CC MC**



HWKT-05355X

HARDWARE DESCRIPTION		QTY.
HHCS-00568X	3/8"-16 X 1" GRADE 5 HEX CAP	6
CLIP-00647X	3/8"-16 X 1 3/4" BARREL NUT	6
FLTW-00663X	3/8" USS FLAT WASHER	6
FLHB-00797X	M8-1.25 X 25MM CLASS 8.8 HEX SERRATED FLANGE BOLT	6
FLNT-00696X	M8-1.25 CLASS 8 SERRATED FLANGE NUT	6
CARB-00661X	3/8"-16 X 3/4" GRADE 5 CARRIAGE BOLT	12
FLNT-00664X	3/8"-16 GRADE 5 SERRATED FLANGE NUT	12

PARTS INCLUDED	QTY
Step Rail	2
Rocker panel mounting brackets	6

Step 1: Identify driver side step.

EXD20CC-TX

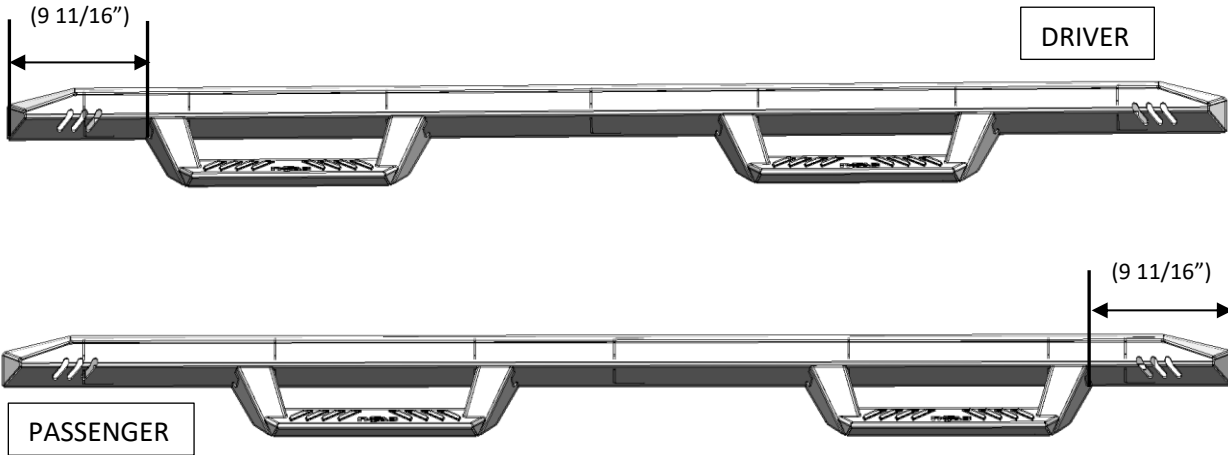

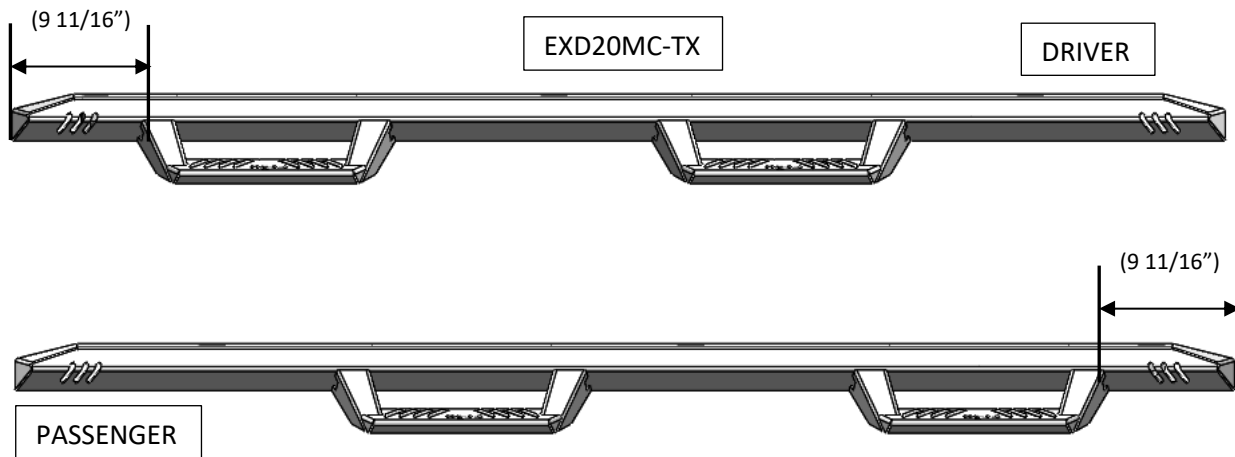

Step 2: Install three rocker panel brackets to the attachments points located on the backside of the channel using the supplied 3/8" x 3/4" carriage bolts and 3/8" flanged nuts. Leave finger tight for now.
NOTE: BE SURE THE BEND DIRECTION OF EACH BRACKET IS CORRECT ON THE DRIVER AND PASSENGER RAIL.

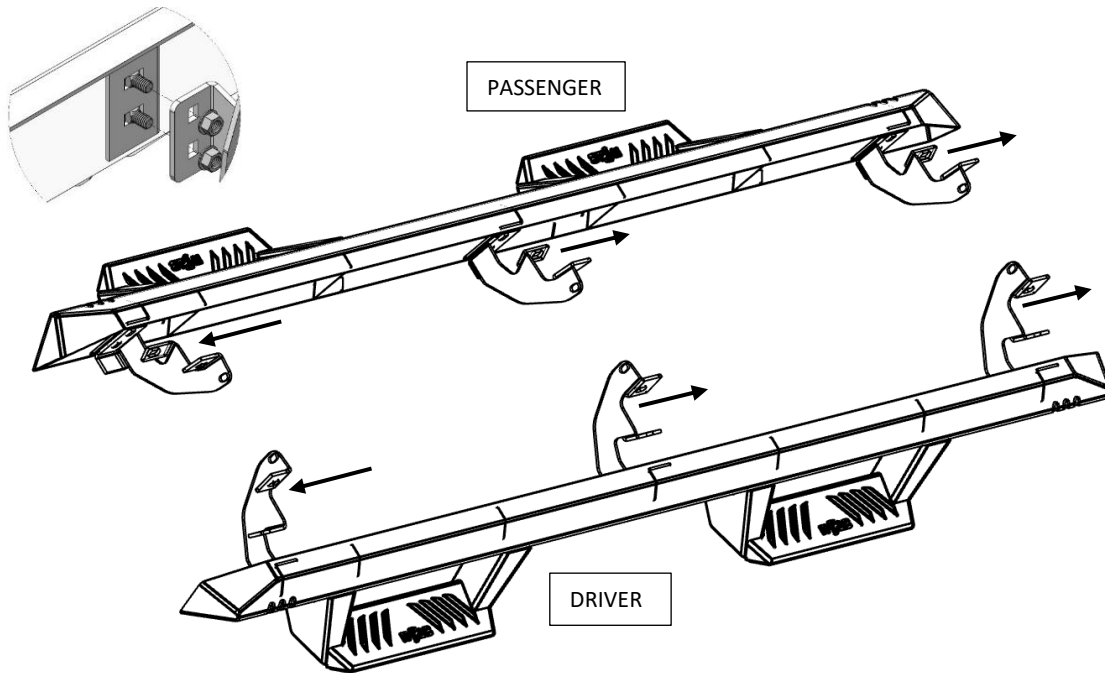

Step 3: Remove any factory running boards or steps and discard.

Step 4: Next, locate the mounting holes underneath the body and remove the factory tape from the three locations.

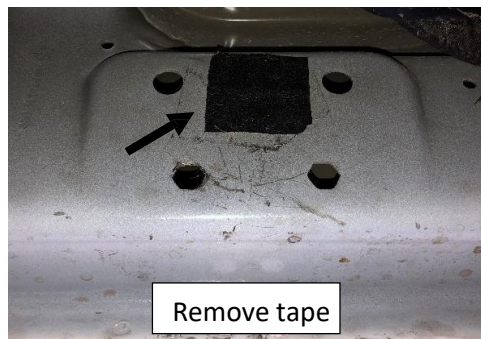



I-SHEET PART NUMBER: INST-00154
PART NUMBER: EXD20CC-TX, EXD20MC-TX
PRODUCT: EYPX HOOP STEP
APPLICATION: RAM 2500/3500 CC MC

Step 5: Insert the supplied threaded U- clips in each mounting location.

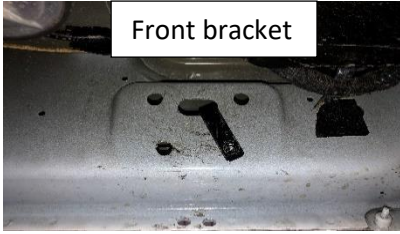

U-clip positioning. **NOTE:** Clips will also face forward for passenger side.

Step 6: Carefully place step into position and start the upper 3/8"x1" hex bolt and 3/8" flat washer in the center bracket and hand tighten to hold in place. Next, install the remainder 3/8"x1" hex bolts and 3/8" washer in the front and rear brackets and leave loose for now.



Step 7: Insert the black zinc M8 flanged bolts and flanged nuts in the pinch weld holes and leave loose for now.



Step 8: Begin tightening the lower attachment points starting with the rear bracket working your way up to the front bracket. (20ft/lbs)

Step 9: Finish by tightening the upper attachments points from front to back. (20ft/lbs)



Step 10: Next, adjust the step assembly up/down and front/back to level out the step rail with body panel and then tighten step to brackets at 20 ft. /lbs.

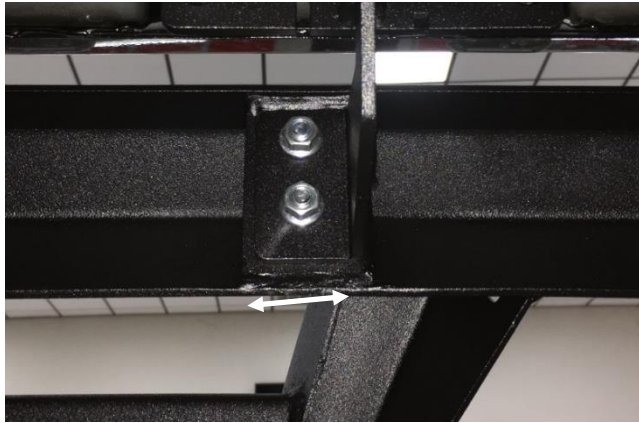

Step 11: Adjust the step rail to where you have approximately ¼" gap between the body of the vehicle and the top of the rail.



Step 12: After final adjustment, tighten all rocker panel brackets to 30 ft./lbs.

Step 13: Re-peat steps 2-8 for passenger side.