



PART NUMBER: **EXD19CC-TX**
 PRODUCT: **EPYX HOOP STEP**
 APPLICATION: **2019- C RAM 1500**



| HARDWARE DESCRIPTION | QTY. |
|----------------------------|------|
| Kit# HWKT-00032X | |
| M8 – 1.25 HX FLANGED NUT | 18 |
| 3/8" x 3/4" carriage bolts | 12 |
| 3/8" Flanged nuts | 12 |

DO NOT USE IMPACT TOOLS

| PARTS INCLUDED | QTY |
|--------------------------------|-----|
| Step Rail | 2 |
| Rocker Panel mounting Brackets | 6 |
| RECOMMENDED TOOLS | |
| RATCHET | |
| 13mm deep socket | |
| 9/16 socket | |

Step 1: Starting with the driver side, remove any steps and old hardware from the vehicle.



Step 2: Locate the driver side step rail.

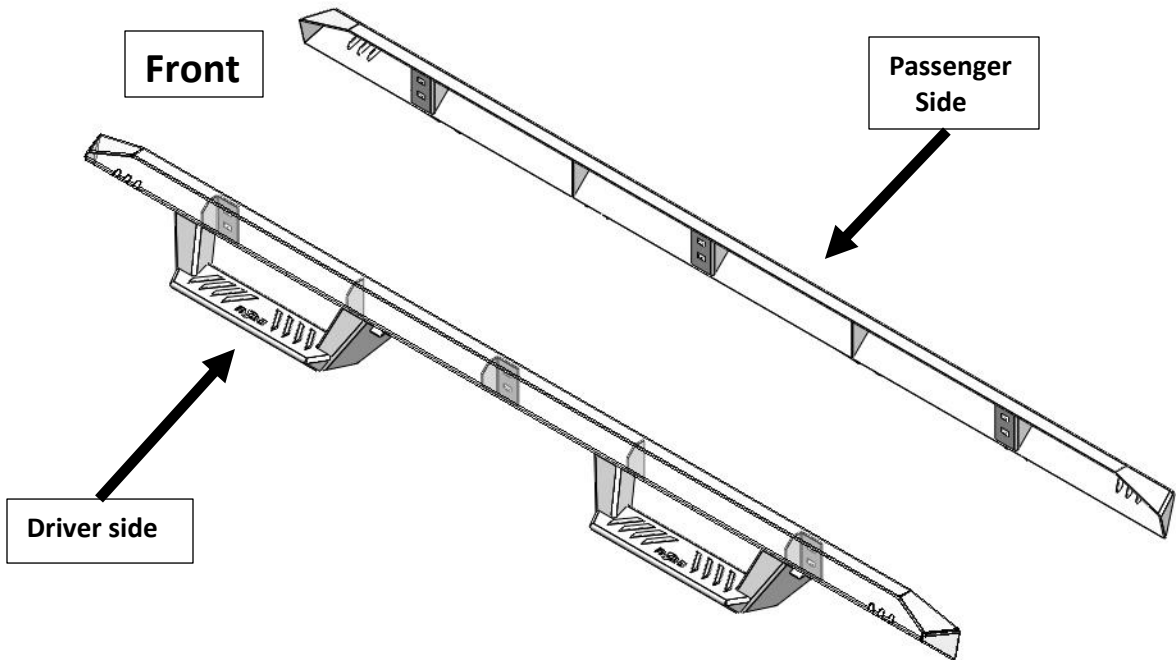

Step 3: Install three rocker panel brackets to the attachments points located on the backside of the channel using the supplied 3/8" x 3/4" carriage bolts and 3/8" flanged nuts. Leave finger tight for now.

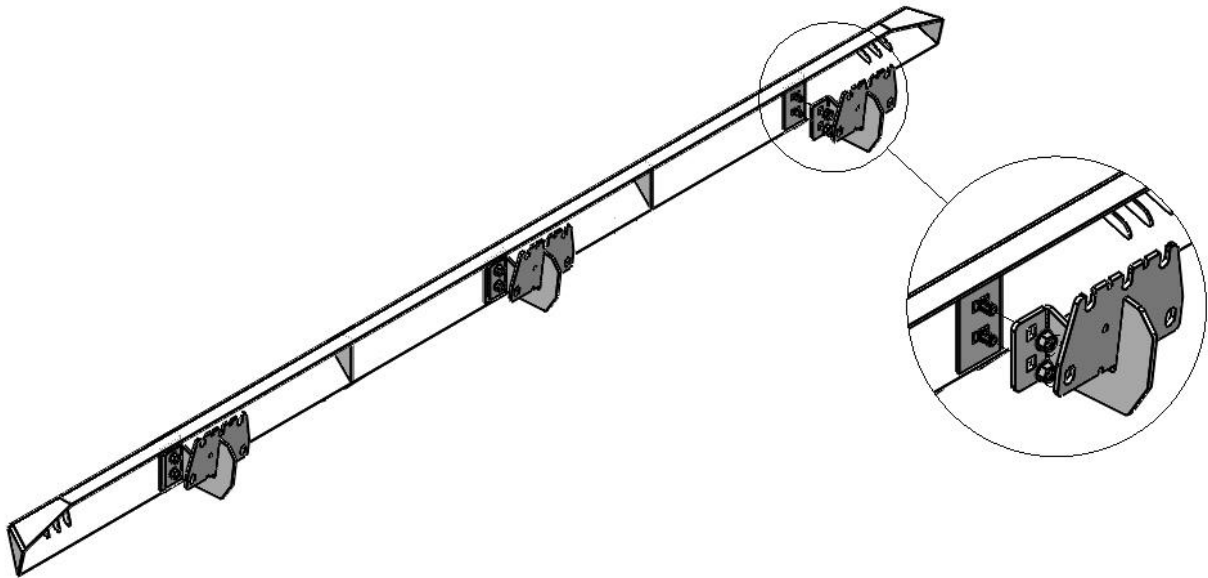



PART NUMBER: **EXD19CC-TX**
PRODUCT: **EPYX HOOP STEP**
APPLICATION: **2019- C RAM 1500**

Step 4: On the inside rocker panel there will be three-attachment point consisting of three 8mm studs coming out from the panel. These studs may be covered in paint and will need to be cleaned before the installation.



Step 5: An additional person is recommended for this step. Carefully install the step assembly to the three factory attachment points using the provided M8 flanged hex nuts. Leave finger tight for now.



Step 6: Next, adjust the step assembly up/down and front/back to level out the step rail with body panel and then tighten step to brackets at 30 ft. /lbs.

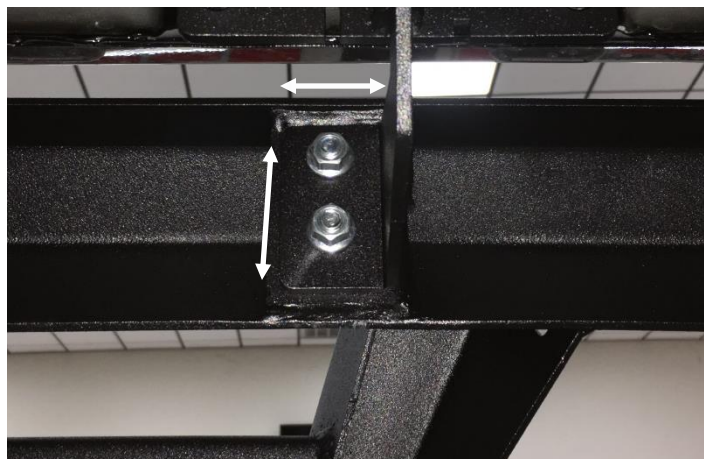

Step 7: Adjust the step rail to where you have approximately $\frac{1}{4}$ " gap between the body of the vehicle and the top of the rail.



Step 8: After final adjustment, tighten all rocker panel brackets to 30 ft./lbs.

Step 9: Re-peat steps 3-8 for passenger side.