



PART NUMBER: EXD15QC-TX, EXD15CC-TX
 PRODUCT: EPYX HOOP STEEPS
 APPLICATION: 15-18 RAM 1500
 QUAD CAB/CREW CAB



PARTS INCLUDED	QTY
Step Rail	2
Rocker Panel mounting Brackets	6

HARDWARE DESCRIPTION	QTY.
# HWKT-00039X	
3/8 U CLIP LONG LUNUT38	10
3/8 USS FLAT WASHER ZNC	2
3/8-16X1 1/2 HEX C/S GR 5 ZNC	10
M8 FENDER WASHER	12
M8 LOCK WASHER	12
M8X35MM HEX BOLT	12
3/8" x 3/4" carriage bolts	12
3/8" Flanged nuts	12

DO NOT USE IMPACT TOOLS

Step 1: Locate the driver side step rail.

EXD15CC-TX

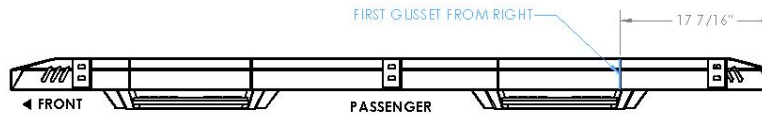
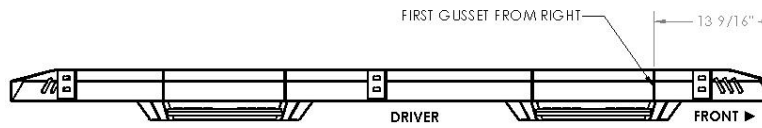

EXD15QC-TX

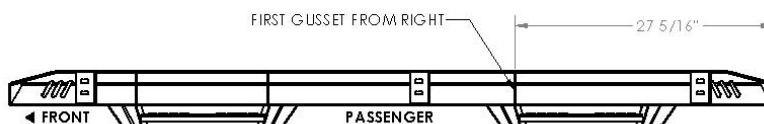
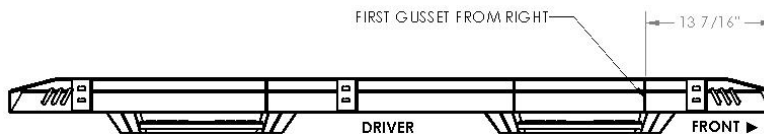

Step 2: Install three rocker panel brackets to the attachments points located on the backside of the channel using the supplied 3/8" x 3/4" carriage bolts and 3/8" flanged nuts. Leave finger tight for now.
NOTE: BE SURE THE BEND DIRECTION OF EACH BRACKET IS CORRECT ON THE DRIVER AND PASSENGER RAIL.

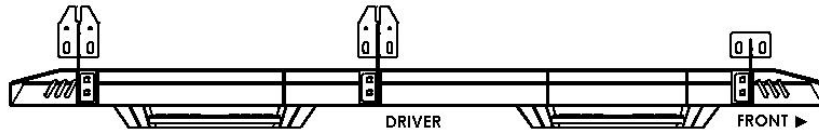

EXD15QC-TX

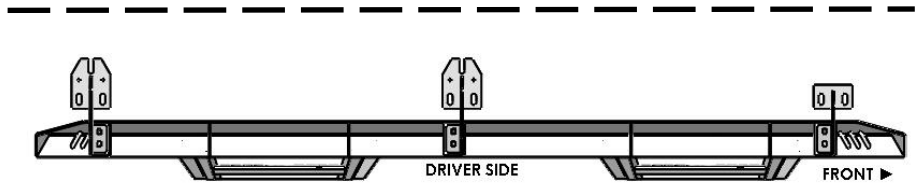
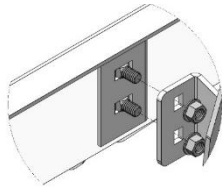
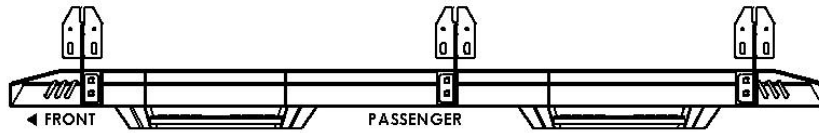

EXD15CC-TX

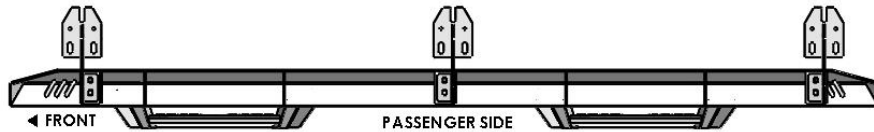

Step 3: Locate the six sets factory mounting hex holes (3 on each side of the vehicle). These are positioned on the vertical sides of the floor pan beneath the doors, with one set of holes each in the front, middle, and rear of the vehicle cab. **NOTE: If your model is equipped with the M8 threaded inserts skip step 4.**



PART NUMBER: EXD15QC-TX, EXD15CC-TX
PRODUCT: EPYX HOOP STEEPS
APPLICATION: 15-18 RAM 1500
QUAD CAB/CREW CAB

Step 4: Using the 3/8" threaded clips, slide two clips in the upper rectangular hole, and align one clip in each hex hole so the clip threads are visible.

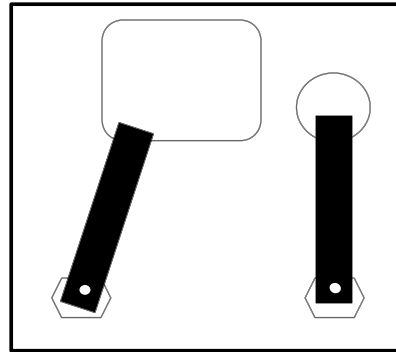
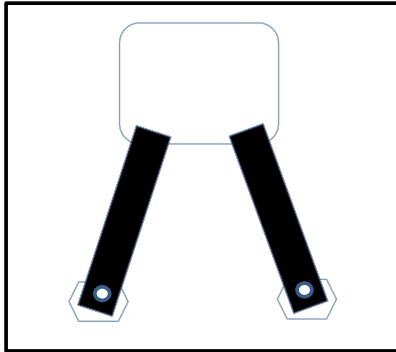

Some modes may require drilling a 1" hole in the rear attachment point in the body panel to extend the threaded clip to the opening.

Step 5: Align the Nerf Step brackets with the three mounting locations on the underside of the vehicle. Start all six M8 hardware or 3/8" x 1.5" hex bolts with washers and hand tighten.

Step 6: Using a sharpie, outline the upper "U" shaped mount in the center bracket.



Step 7: Remove Nerf Step and set aside. Next, slide the additional 3/8 threaded clip from the upper rectangle hole and align with the “U” shaped mark. Make a mark through the threaded part of the clip.



Step 8: Remove clip. Use a 1/2” drill bit and drill out the center mark. Slide the 3/8 clip back into position so the threaded part is aligned with the hole.

Step 9: Repeat Step 4 with the additional upper clip. Starting with the rear Bracket, raise the Nerf step into position and torque the bolts to 15-20 ft./lbs. Move to the front bracket and torque bolts. Then to the center brackets and torque down bolts

Step 10: Repeat Steps 2-7 for passenger side.