



PART NUMBER: **EXC17CC-TX**  
 PRODUCT: **EPYX HOOP STEP**  
 APPLICATION: **17-19 CHEVY/GM 2500/3500**  
**CREW CAB DIESEL**



PARTS INCLUDED	QTY
Step Rail	2
Rocker Panel mounting Brackets	9

HARDWARE DESCRIPTION	QTY.
<b># HWKT-00044X</b>	
M8X25mm Hex bolt	11
M8 Hex nuts	5
Fender washer	11
M8 Speed clips	3
3/8" x 1" Flanged Hex Bolt	2
3/8" x 3/4" carriage bolts	14
3/8" Flanged nuts	14

**DO NOT USE IMPACT TOOLS**

**Step 1:** Locate the driver side step rail.

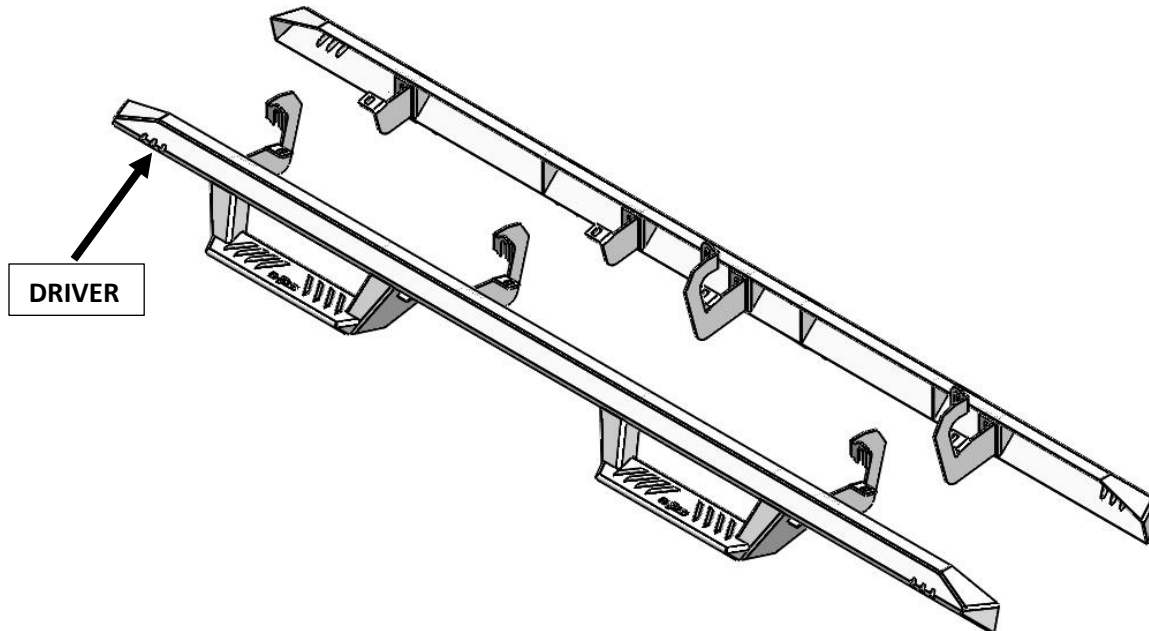

**Step 2:** Install the rocker panel brackets to the attachment points located on the backside of the channel using the supplied 3/8" x 3/4" carriage bolts and 3/8" flanged nuts. Leave finger tight for now.  
**NOTE:** *The two short bracket will mount on the passenger side rail in the first and second position with the two tall brackets in the third and fourth position to clear the DEF tank.*

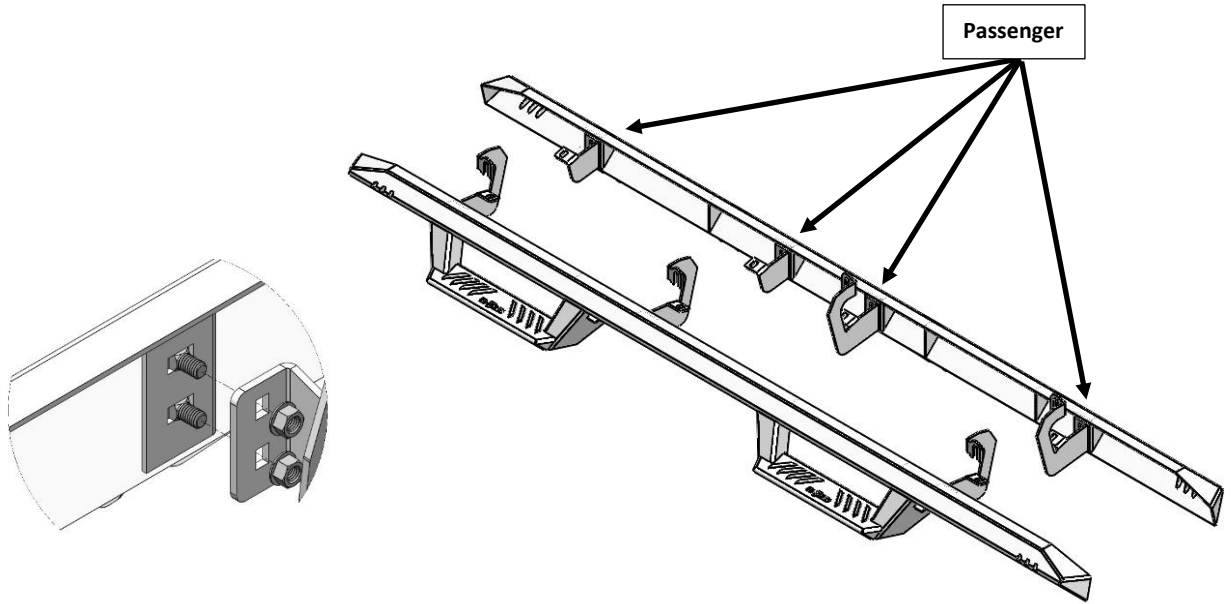

**Step 3:** With the correct step in placed on each side of the vehicle, take note of where the brackets are located. Look on the underside of the body and locate the factory supplied mounting positions.  
**NOTE:** *Some vehicles require the use of speed clips and nuts which are supplied with the hardware kit.*

**Step 4:** If your vehicle requires the use of the speed clips, install at this time. This requires the removal of a plastic body plug. Using a flat head screw driver remove the plug and install one of the supplied speed clips.





PART NUMBER: **EXC17CC-TX**  
PRODUCT: **EPYX HOOP STEP**  
APPLICATION: **17-19 CHEVY/GM 2500/3500**  
**CREW CAB DIESEL**

**Step 5:** Carefully lift up step assembly into position aligning the brackets to the mounting locations in the body of the vehicle and install hardware. Do not tighten all the way. **NOTE: Some vehicles may require the use of additional nuts and washers for the lower portion of the mounting bracket which are supplied in the hardware kit.**

**Step 6:** Next, adjust the step assembly up/down and front/back to level out the step rail with body panel and then tighten step to brackets at 30 ft. /lbs.



**Step 7:** After final positioning, start at the rear of the vehicle and tighten the lower portion of the bracket to 15-20 ft/lbs of torque. Continue this until all of the lower have been tighten then move to the top bolt and repeat the process.

## Passenger Side Install with DEF Tank

**Step 1:** Remove the seven bolts that attach the DEF tank cover and remove. The cover will be re-installed later.







PART NUMBER: **EXC17CC-TX**  
PRODUCT: **EPYX HOOP STEP**  
APPLICATION: **17-19 CHEVY/GM 2500/3500  
CREW CAB DIESEL**

**Step 2:** Take the bracket with the bent hook and feed between the body and DEF tank until you locate the tab into the OE hole. The bracket will hang once placed correctly.

**Step 3:** The second bracket will attach to the body with one of the supplied M8x25 mm hex bolts and washer.

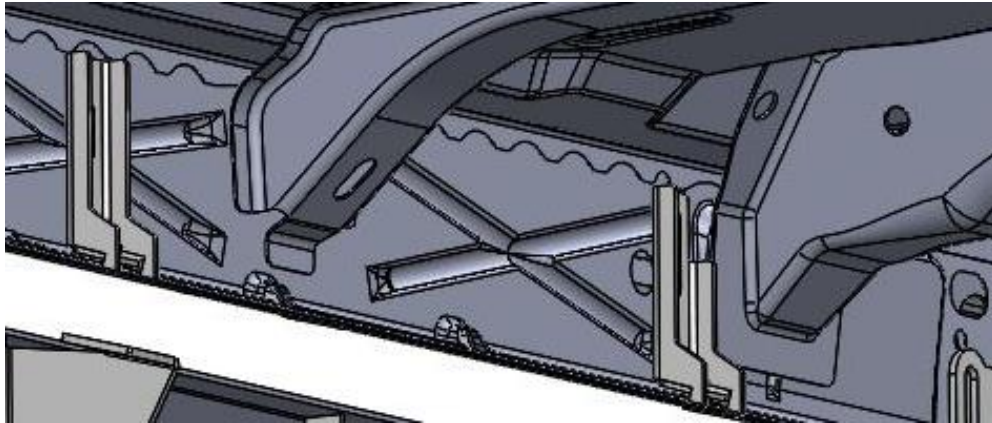
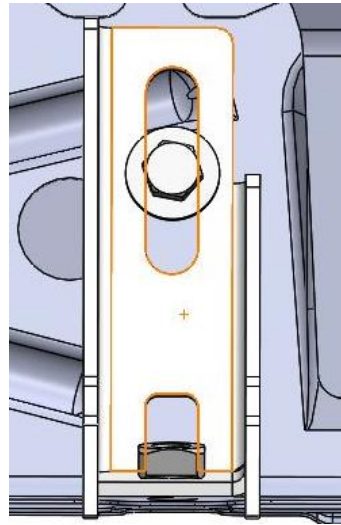
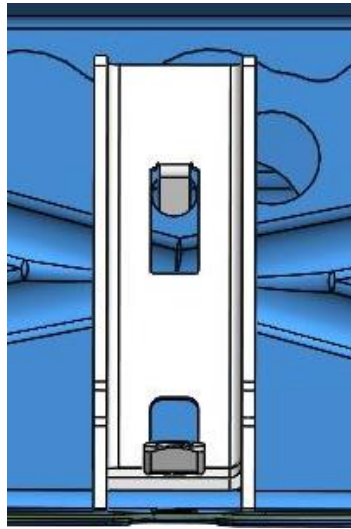

**Step 4:** Carefully place step rail into place. Using the supplied M8x25mm hex bolts and washers begin hand tightening both upper and lower mounts to the rear two brackets. An assistant is recommended with this procedure.

**Step 5:** Next, attach the two front brackets to the rocker panel brackets that you installed in step 2 and 3 hand tighten.

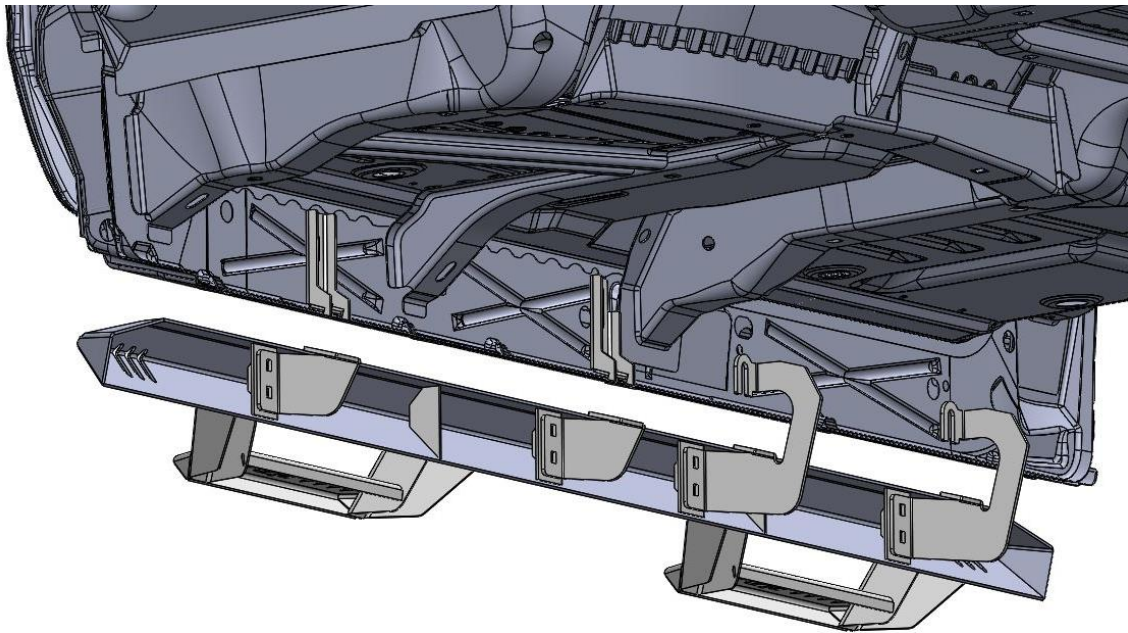

**Step 6:** Next, adjust the step assembly up/down and front/back to level out the step rail with body panel and then tighten step to brackets at 30 ft. /lbs.



**Step 7:** After final positioning, start at the rear of the vehicle and tighten the lower portion of the bracket to 15-20 ft/lbs of torque. Continue this until all of the lower have been tighten then move to the top bolt and repeat the process.

**Step 8:** Re-install the DEF tank cover that was removed in step 1. Torque to factory specs.