



PART NUMBER: **EXC11CC-TX**
 PRODUCT: **EPYX HOOP STEP**
 APPLICATION: **CHEVY 11-16 2500/3500**
CREW CAB DIESEL



| PARTS INCLUDED | QTY |
|--------------------------------|-----|
| Step Rail | 2 |
| Rocker Panel mounting Brackets | 7 |

DO NOT USE IMPACT TOOLS

Step 1: Locate the driver side step rail.

| HARDWARE DESCRIPTION | QTY. |
|-------------------------------------|------|
| # HWKT-00099X | |
| M8 CLIP | 2 |
| M8-1.25 HEX FIN NUT DIN 934 CL 8ZNC | 5 |
| M8-1.25X25 HX C/S 8.8 ZP DIN933 | 10 |
| M10 F/W DIN9021 ZNC | 10 |
| 3/8" x 1" Flanged Hex bolt | 1 |
| 3/8" x 3/4" carriage bolts | 12 |
| 3/8" Flanged nuts | 12 |

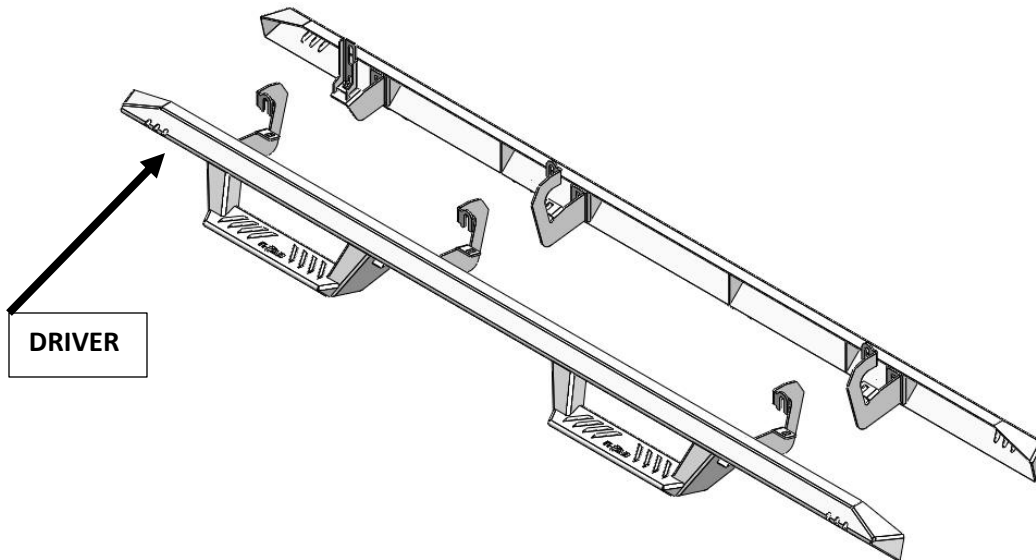

Step 2: Install three rocker panel brackets to the attachments points located on the backside of the channel using the supplied 3/8" x 3/4" carriage bolts and 3/8" flanged nuts. Leave finger tight for now.

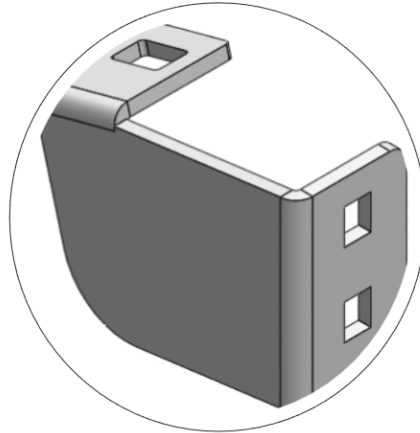
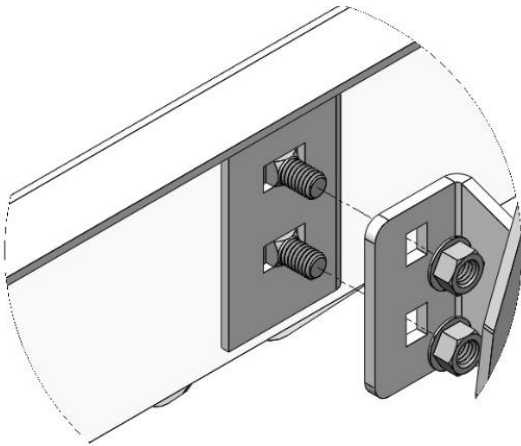

Front bracket for passenger side.

Step 3: Look on the underside of the body and locate the factory supplied mounting positions. **NOTE:** Some vehicles require the use of speed clips and nuts, which are supplied with the hardware kit.

Step 4: If your vehicle requires the use of the speed clips, install at this time. This requires the removal of a plastic body plug. Using a flat head screwdriver remove the plug and install one of the supplied speed clips.



Step 5: Align the steps with the mounting holes. Beginning with the middle bracket, use one M8-1.25 bolt and one fender washer for each mounting location and thread the bolts into the mounting holes and leave loose. Continue with the front and rear bracket. **NOTE: Some vehicles require the use of an additional nut and washer for the lower portion of the mounting bracket.**



PART NUMBER: **EXC11CC-TX**
PRODUCT: **EPYX HOOP STEP**
APPLICATION: **CHEVY 11-16 2500/3500**
CREW CAB DIESEL

Step 6: Next, adjust the step assembly up/down and front/back to level out the step rail with body panel and then tighten step to brackets at 30 ft. /lbs.



Step 7: After final positioning, begin at the rear bracket and tighten the lower bolt to 15-20 ft. /lb. Continue to the front bracket and then to the center bracket. Next, tighten the upper mounts from front to back at 15-20 ft. /lb.

Passenger Side Install with DEF Tank

Step 1. Remove the (x3) 13mm bolts, (x2) 10mm bolts and (x2) 10mm nuts that attach the Def tank cover and remove.





PART NUMBER: **EXC11CC-TX**
PRODUCT: **EPYX HOOP STEP**
APPLICATION: **CHEVY 11-16 2500/3500**
CREW CAB DIESEL

Step 2: Take the short bracket with the bent hook and feed between the body and DEF tank until you locate the tab into the OE hole. The bracket will hang once placed correctly.

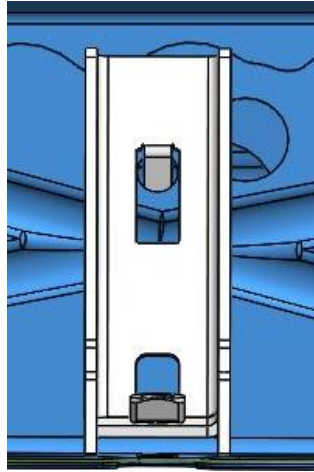

Step 3: Carefully place step rail into place. Using the supplied M8x25mm hex bolts and washers begin hand tightening both upper and lower mounts to the rear two brackets. An assistant is recommended with this procedure.

Step 4: Next, attach the front bracket to the rocker panel bracket with the supplied 3/8" x 1" flanged hex bolt that you installed in step 2 and hand tighten.

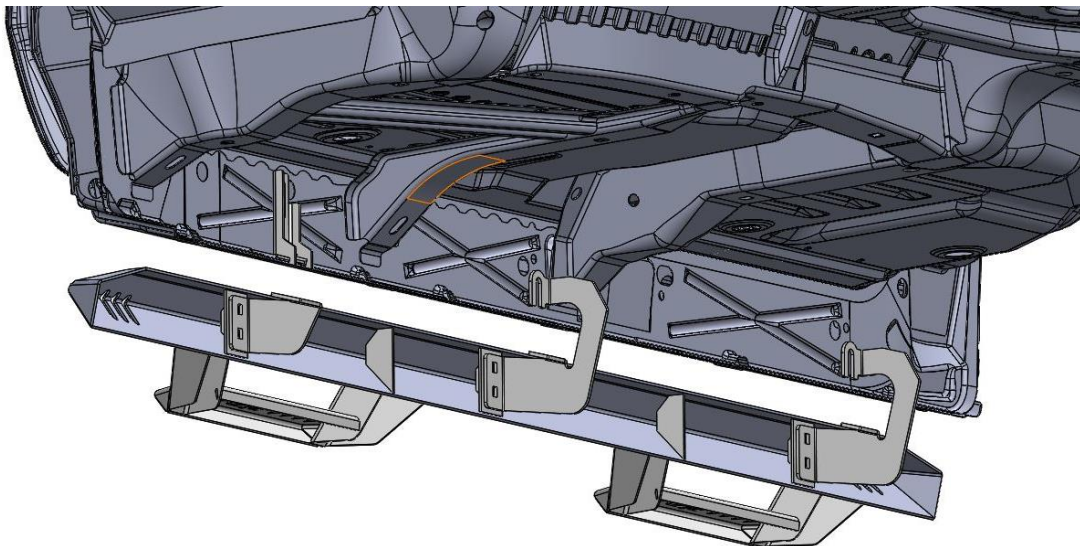

Step 5: Next, adjust the step assembly up/down and front/back to level out the step rail with body panel and then tighten step to brackets at 30 ft. /lbs.



Step 6: After final positioning, start at the rear of the vehicle and tighten the lower portion of the bracket to 15-20 ft/lbs of torque. Continue this until all of the lower have been tighten then move to the top bolt and repeat the process.

Step 7: Re-install the DEF tank cover that was removed in step 1. Torque to factory specs. This completes the install for the passenger side.