



I-SHEET NUMBER: INST-00073
 PART NUMBER: ALL CREW CAB/QUAD CAB
 PRODUCT: HOOP STEP
 APPLICATION: 19-20 CHEVY/GM/CC/QC
 1500/2500/3500/GAS/DIESEL

HARDWARE DESCRIPTION		QTY.
HWKT-03054X		
FLBW-00894X	M8-1.25 X 30MM CLASS 8.8 FLANGE CAP SCREW W/WASHER	12

PARTS INCLUDED	QTY
Driver Side	1
Passenger side	1

DO NOT USE IMPACT TOOLS



Step 1: Locate the driver side step rail.

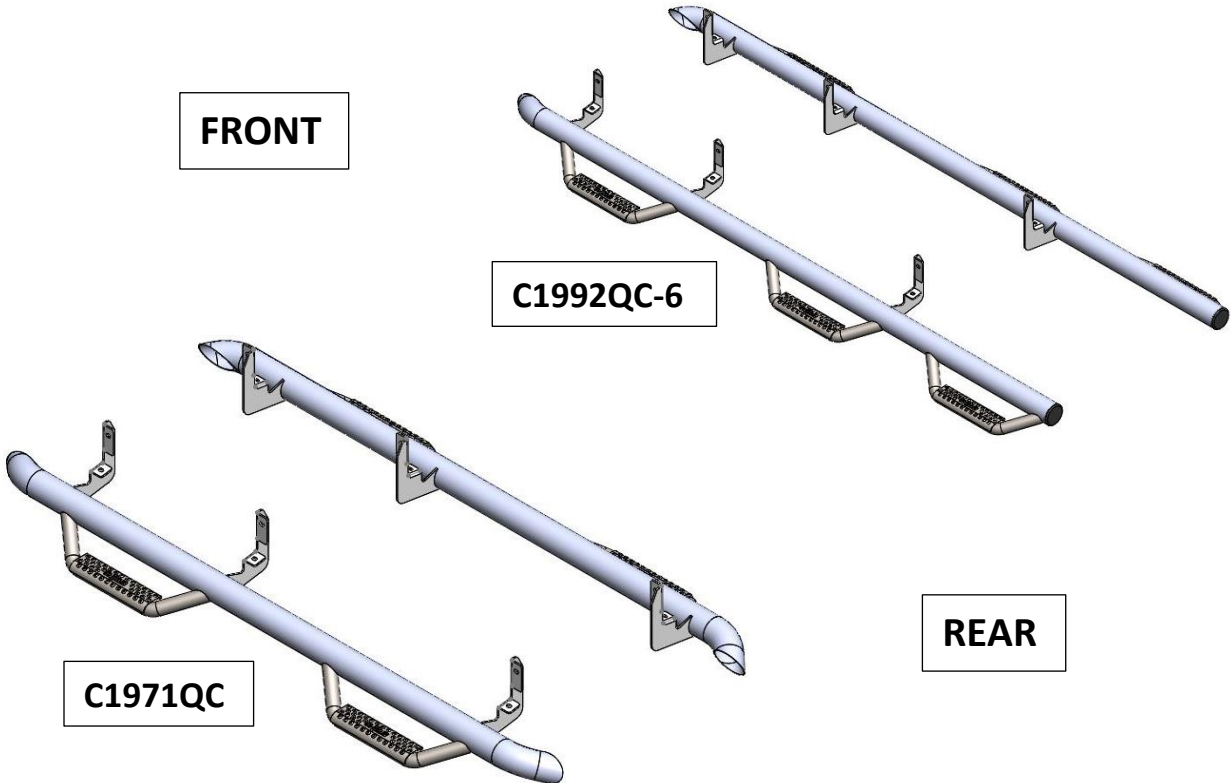

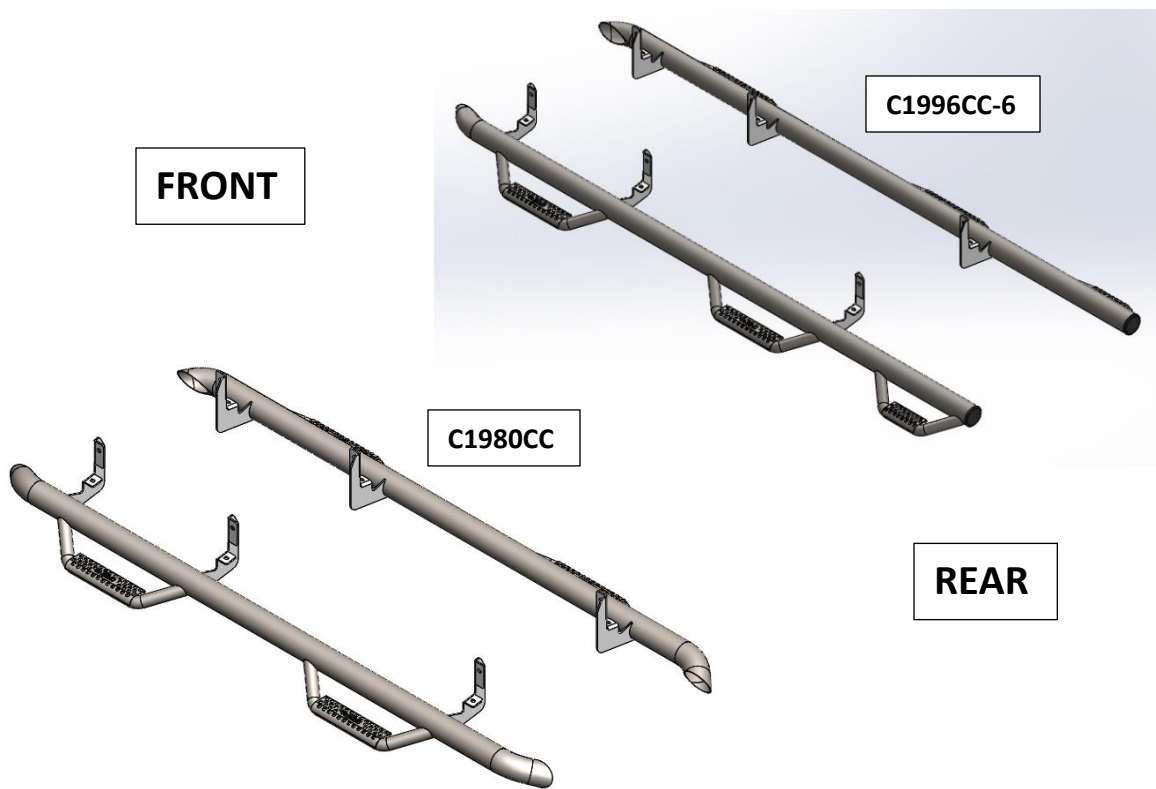

Step 2 Carefully raise the Nerf Step up into position aligning the mounting brackets with the factory-threaded holes. Beginning with the center bracket start one of the supplied M8x30mm Hex bolts in the upper mount and finger tighten. This will allow the Nerf step to be suspended while you start the remainder of the hardware.

Step 3 Next, start all remainder hardware in the factory locations and leave loose.

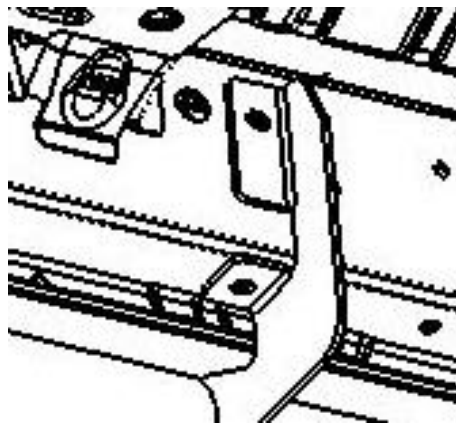

Step 4 After final adjustment tighten all the lower mount first then the upper mounts.

Step 5: Repeat steps 2-4 for the passenger side.