



PART NUMBER: **C194RKRC**, **C194RKCCS4**
 PRODUCT: **RKR RAILS**
 APPLICATION: **19-C CHEVY/GM 1500 CREW CAB**



PARTS INCLUDED Prt# C194RKRC	QTY
RKR RAIL Driver	1
RKR RAIL Passenger	1

PARTS INCLUDED Prt#C194RKCCS4	QTY
RKR RAIL Driver	1
RKR RAIL Passenger	1
Detachable step (1 pair)	2

HARDWARE DESCRIPTION	QTY.
# HWKT-00008X	
M8X30mm Hex Cap with washer	12

DO NOT USE IMPACT TOOLS

Step 1: Locate the driver side step rail.

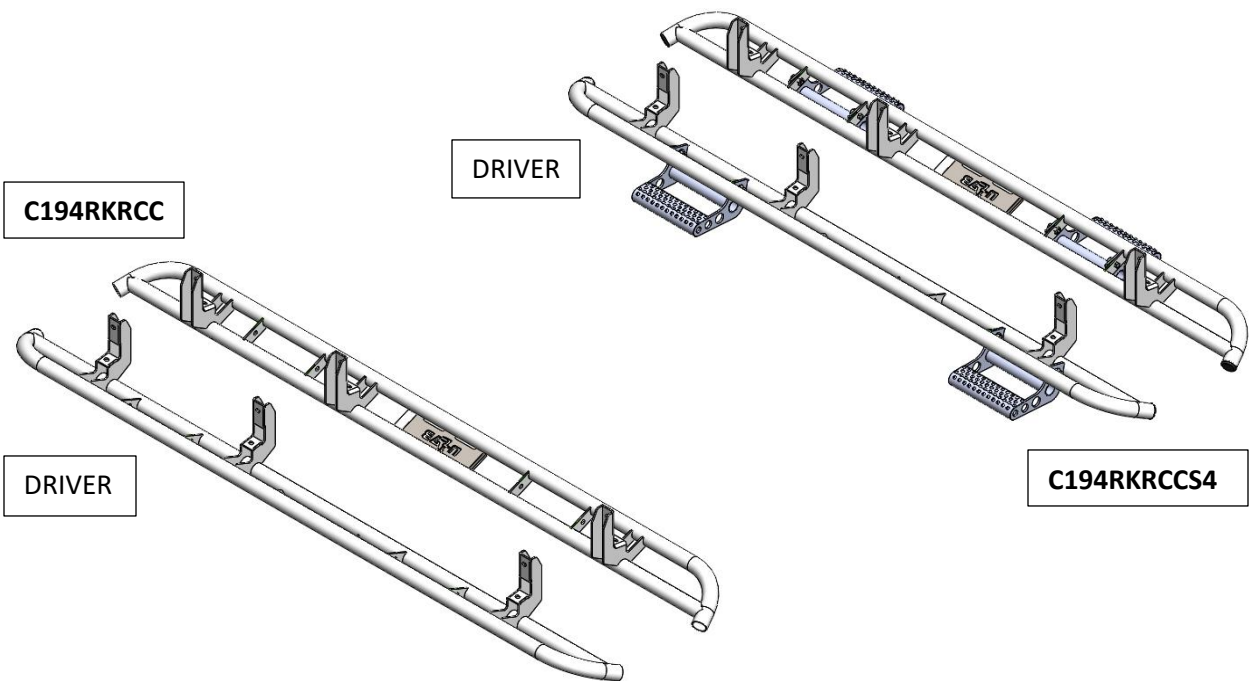

Step 2 Carefully raise the RKR rail up into position aligning the mounting brackets with the factory-threaded holes. Beginning with the center bracket start one of the supplied M8x30mm Hex bolts in the upper mount and finger tighten. This will allow the rail to be suspended while you start the remainder of the hardware.

Step 3 Next, start all remainder hardware in the factory locations and leave loose.

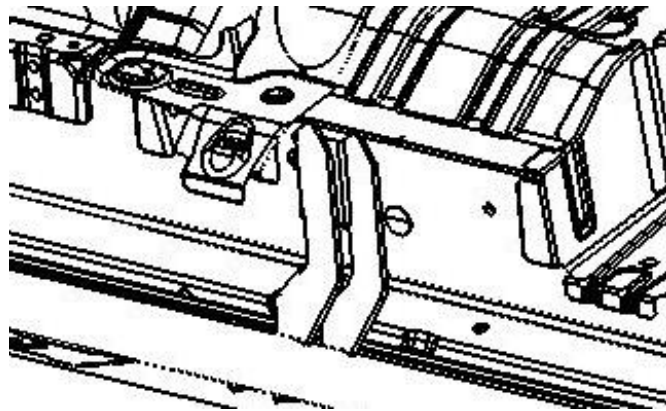

Step 4 After final adjustment tighten all the lower mount first then the upper mounts.

NOTE: You will need an open in wrench/gear wrench for the lower mounts.

Step 5: Repeat steps 2-4 for the passenger side.

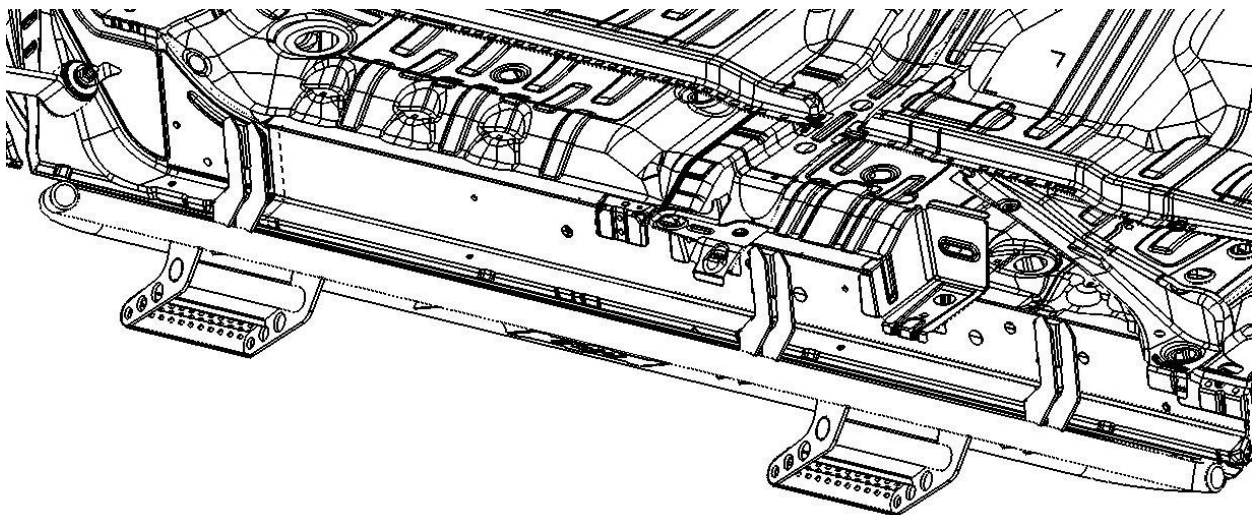



PART NUMBER: C194RKRCC, C194RKRCCS4
PRODUCT: RKR RAILS
APPLICATION: 19-C CHEVY/GM 1500 CREW CAB

Detachable Step Installation

Prt#C194RKRCCS4

PARTS INCLUDED	QTY
Detachable steps (1 pair)	2
HARDWARE:	
½" X 1" Flanged bolt	4
½" Flanged Hex nut	4

Step 1: Attach the step to the mounts located in between the RKR rails using the supplied ½" x 1" Flanged hex bolts and ½" Flanged hex nuts. **NOTE: The step will mount to the left of the bracket opposite of the weld.**

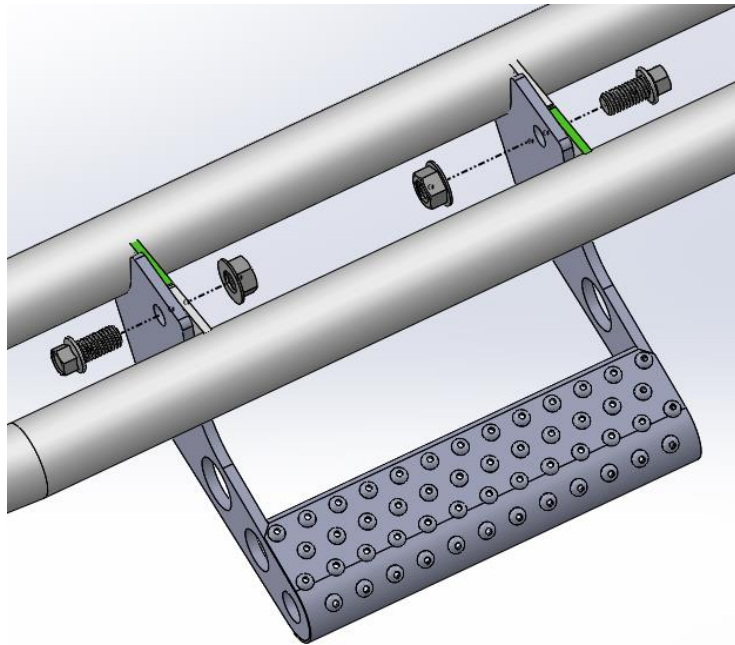

Step 2: Torque bolts to a target torque of 40 ft.-lbs. / 54Nm