

Unpacking

Thank you for buying the MSI® **970A GAMING PRO CARBON** motherboard. Check to make sure your motherboard box contains the following items. If something is missing, contact your dealer as soon as possible.

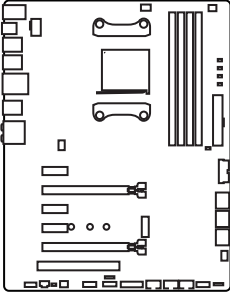

Motherboard

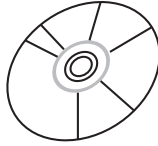

Drivers & Utilities Disc



Motherboard User Guide



I/O Shield

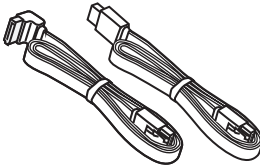

SATA Cable x2

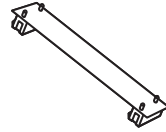

SLI Bridge Connector

Safety Information

- The components included in this package are prone to damage from electrostatic discharge (ESD). Please adhere to the following instructions to ensure successful computer assembly.
- Ensure that all components are securely connected. Loose connections may cause the computer to not recognize a component or fail to start.
- Hold the motherboard by the edges to avoid touching sensitive components.
- It is recommended to wear an electrostatic discharge (ESD) wrist strap when handling the motherboard to prevent electrostatic damage. If an ESD wrist strap is not available, discharge yourself of static electricity by touching another metal object before handling the motherboard.
- Store the motherboard in an electrostatic shielding container or on an anti-static pad whenever the motherboard is not installed.
- Before turning on the computer, ensure that there are no loose screws or metal components on the motherboard or anywhere within the computer case.
- Do not boot the computer before installation is completed. This could cause permanent damage to the components as well as injury to the user.
- If you need help during any installation step, please consult a certified computer technician.
- Always turn off the power supply and unplug the power cord from the power outlet before installing or removing any computer component.
- Keep this user guide for future reference.
- Keep this motherboard away from humidity.
- Make sure that your electrical outlet provides the same voltage as is indicated on the PSU, before connecting the PSU to the electrical outlet.
- Place the power cord such a way that people can not step on it. Do not place anything over the power cord.
- All cautions and warnings on the motherboard should be noted.
- If any of the following situations arises, get the motherboard checked by service personnel:
 - Liquid has penetrated into the computer.
 - The motherboard has been exposed to moisture.
 - The motherboard does not work well or you can not get it work according to user guide.
 - The motherboard has been dropped and damaged.
 - The motherboard has obvious sign of breakage.
- Do not leave this motherboard in an environment above 60°C (140°F), it may damage the motherboard.

Quick Start

Preparing Tools and Components

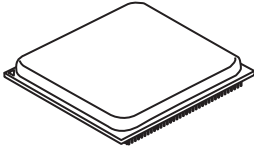

AMD® AM3/ AM3+ CPU

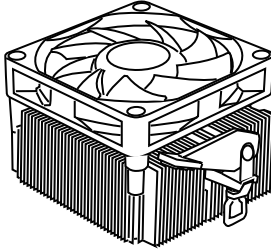

CPU Fan

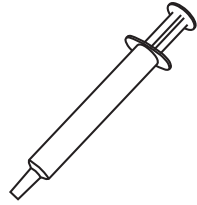

Thermal Paste

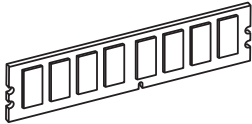

DDR3 Memory

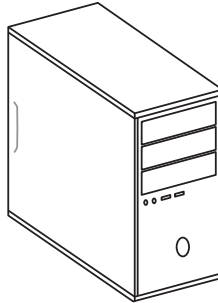

Chassis

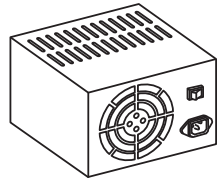

Power Supply Unit

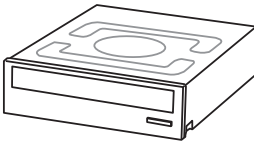

SATA DVD Drive



SATA Hard Disk Drive

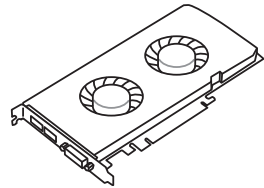

Graphics Card

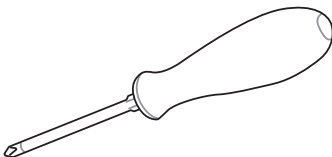

Phillips Screwdriver

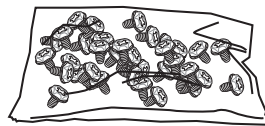

A Package of Screws

Installing a Processor

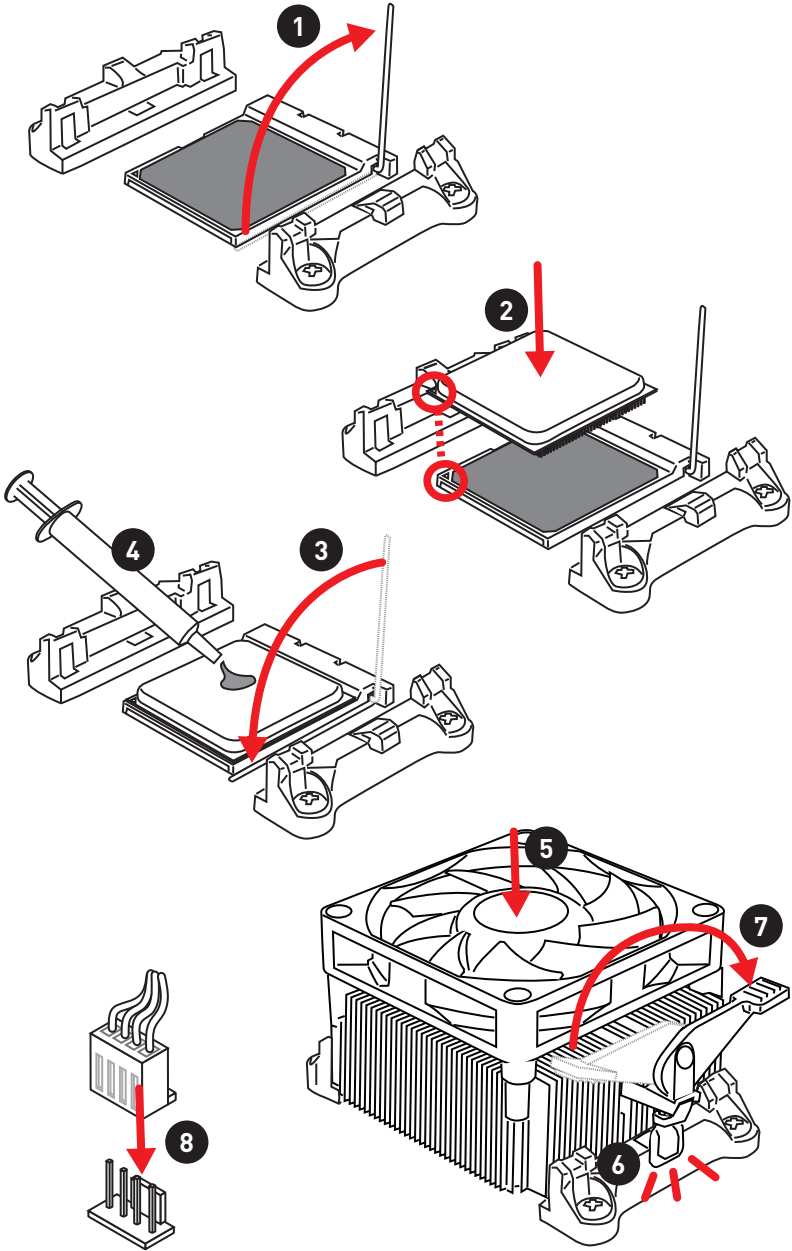

Installing DDR3 memory

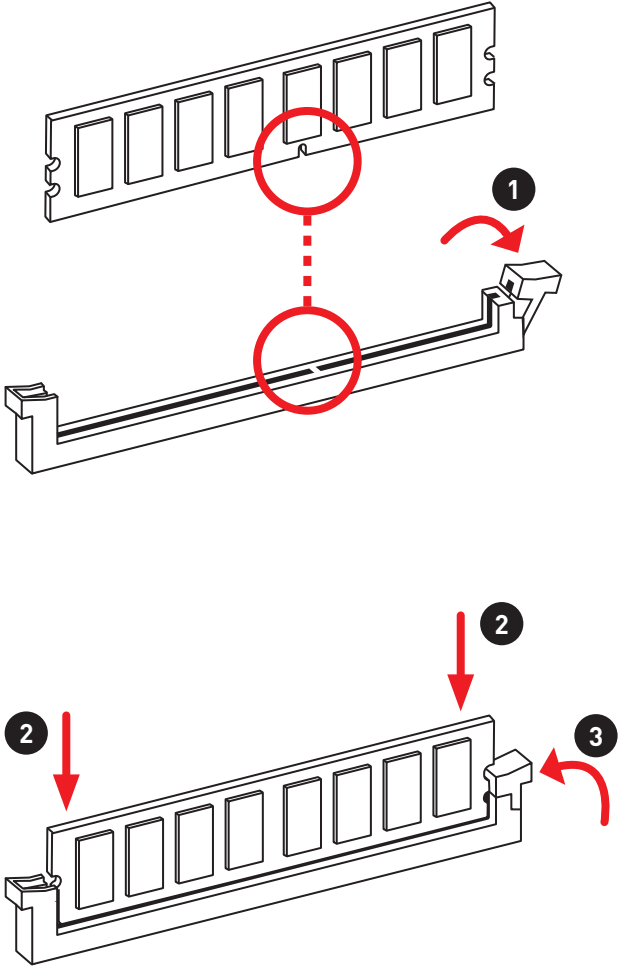

Connecting the Front Panel Header

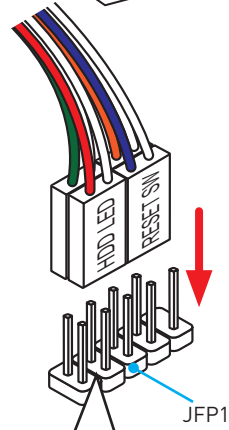
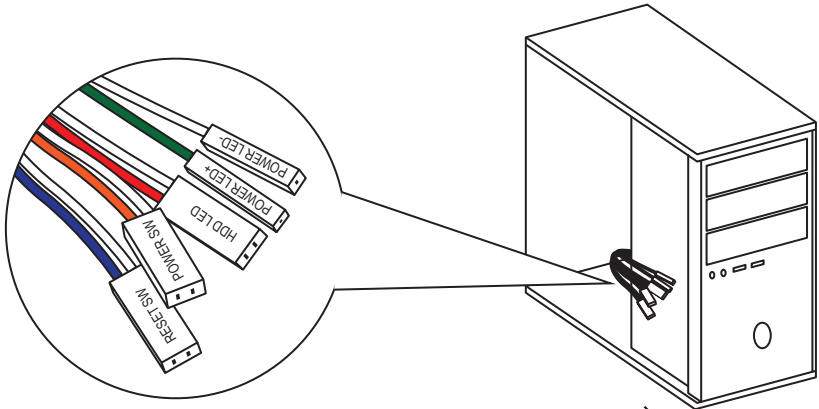

<p>JFP1</p>		1	HDD LED +	2	Power LED +
		3	HDD LED -	4	Power LED -
		5	Reset Switch	6	Power Switch
		7	Reset Switch	8	Power Switch
		9	Reserved	10	No Pin

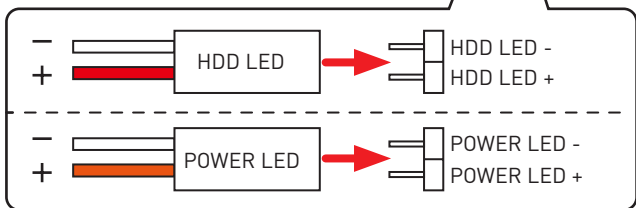

Installing the Motherboard

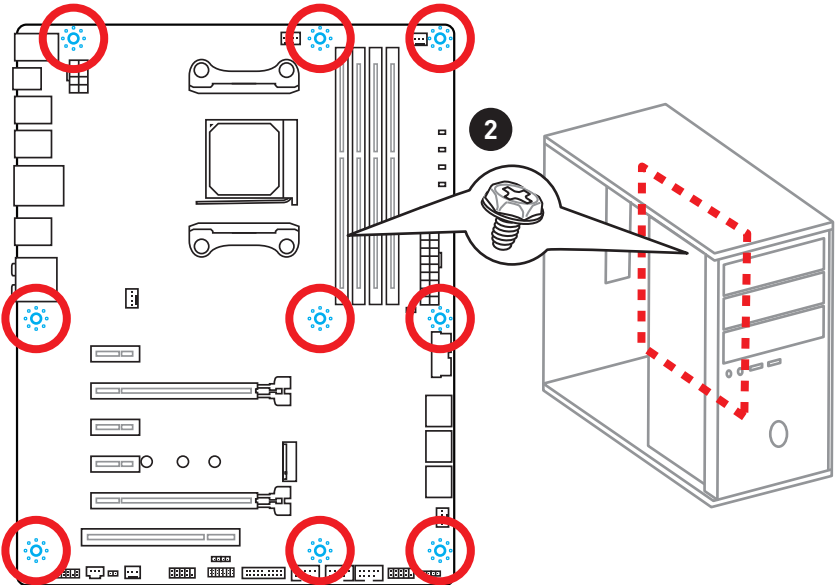
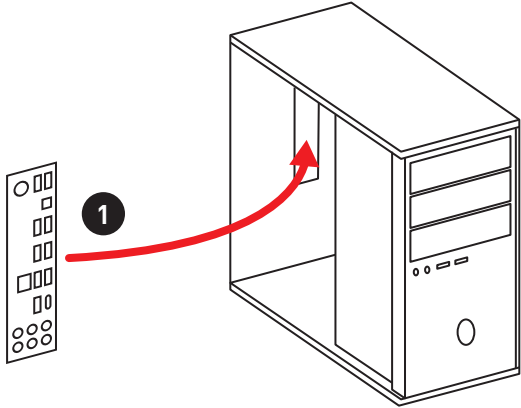

Installing SATA Drives

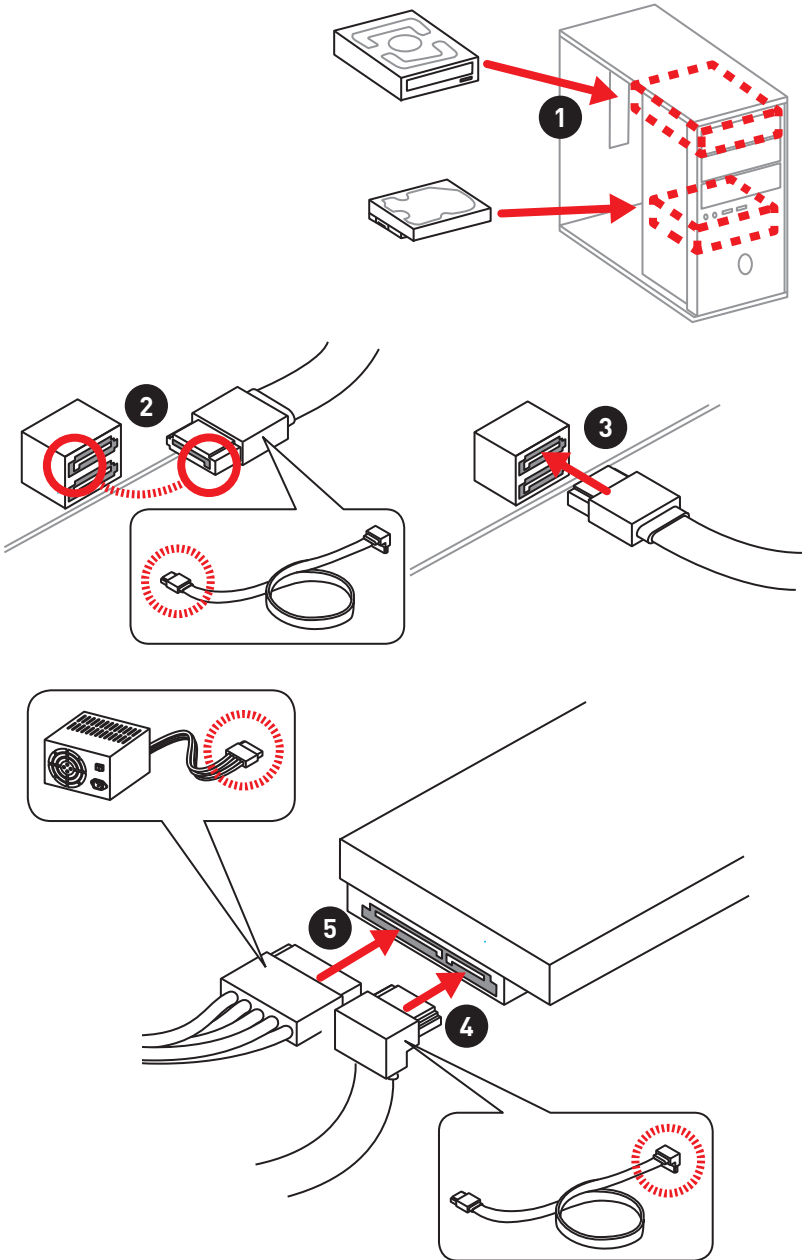

Installing a Graphics Card

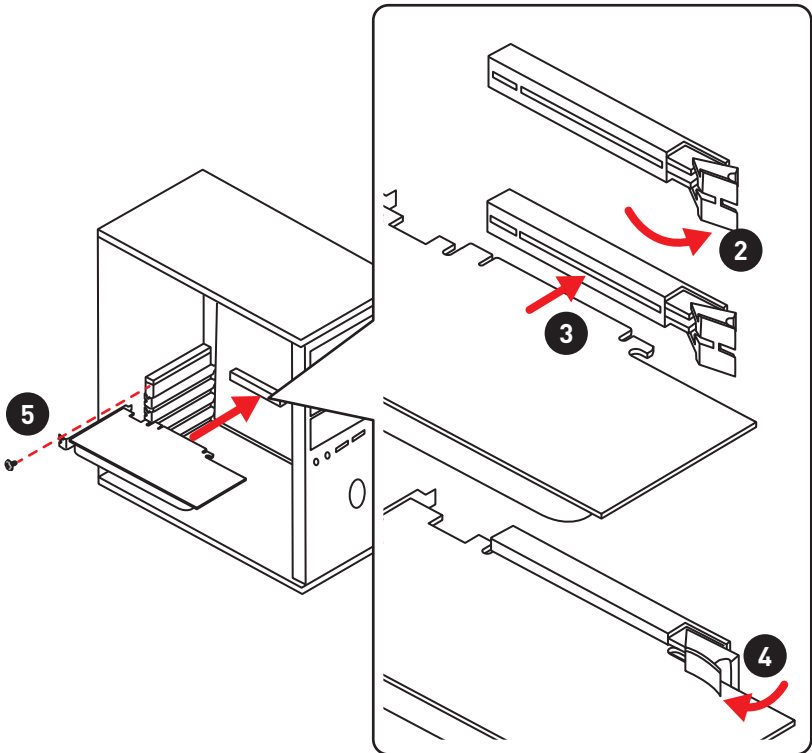
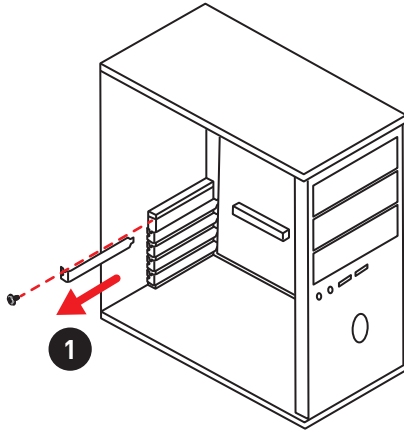

Connecting Peripheral Devices

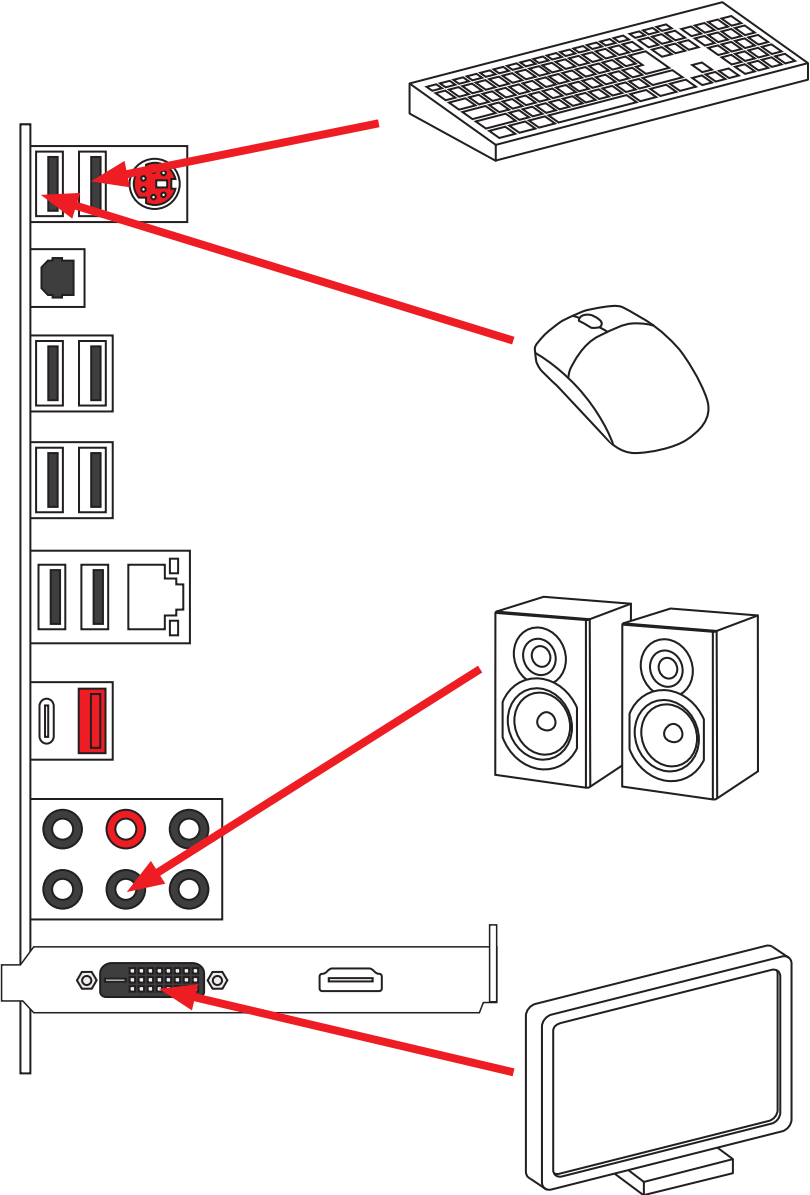

Connecting the Power Connectors

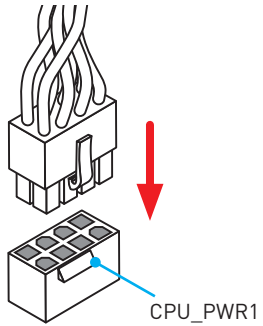
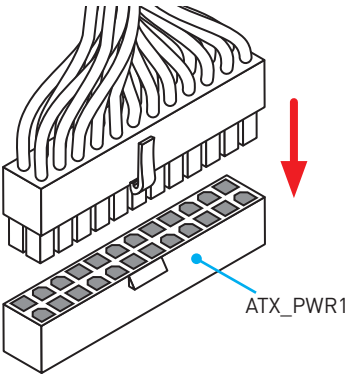
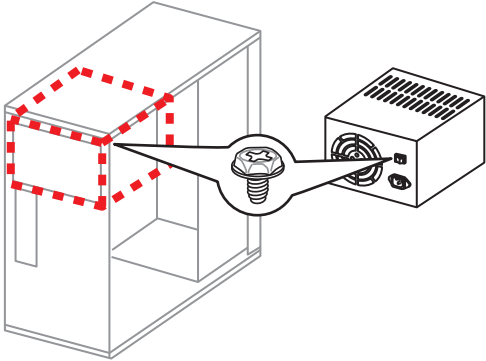

Power On

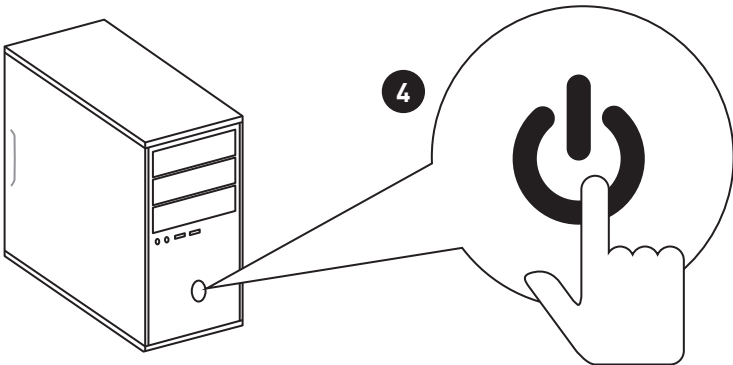
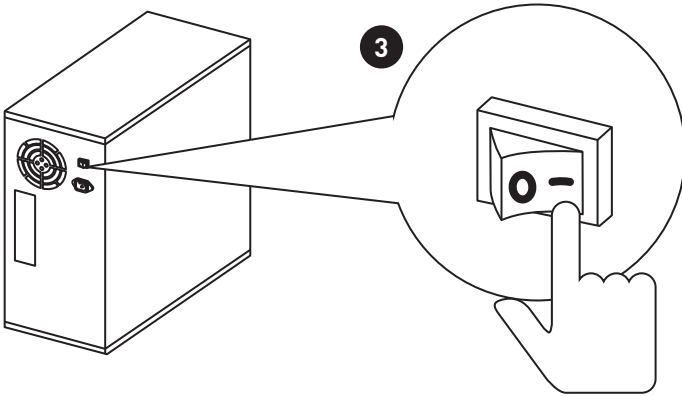
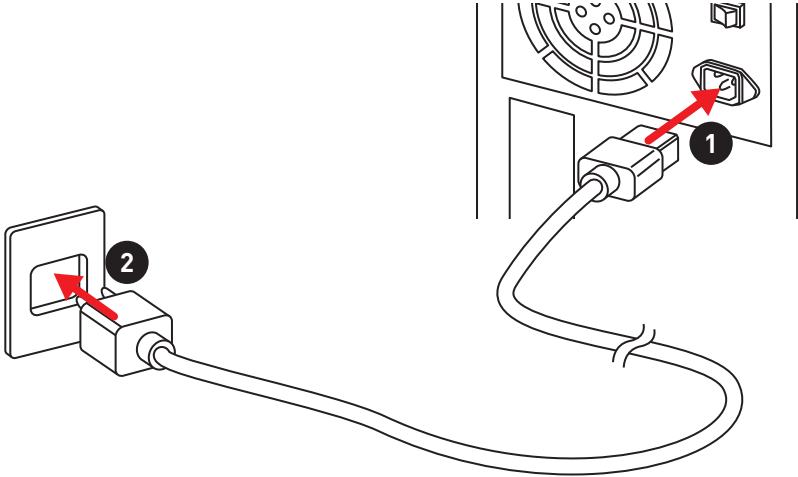

Contents

Unpacking	1
Safety Information	2
Quick Start	3
Preparing Tools and Components	3
Installing a Processor	4
Installing DDR3 memory	5
Connecting the Front Panel Header	6
Installing the Motherboard	7
Installing SATA Drives	8
Installing a Graphics Card	9
Connecting Peripheral Devices	10
Connecting the Power Connectors	11
Power On	12
Specifications	15
Block Diagram	20
Rear I/O Panel	21
LAN Port LED Status Table	21
Audio Ports Configuration	21
Realtek HD Audio Manager	22
Overview of Components	24
CPU Socket	26
DIMM Slots	27
PCI_E1~5, PCI1: PCIe/ PCI Expansion Slots	28
M2_1: M.2 Slot	29
SATA1~6: SATA 6Gb/s Connectors	30
CPU_PWR1, ATX_PWR1: Power Connectors	31
JCOM1: Serial Port Connector	31
JUSB4~5: USB 3.1 Gen1 Connectors	32
JFP1, JFP2: Front Panel Connectors	32
JUSB1~3: USB 2.0 Connectors	33
JTPM1: TPM Module Connector	33
CPU_FAN1, SYS_FAN1~4: Fan Connectors	34
JAUD1: Front Audio Connector	35
JCI1: Chassis Intrusion Connector	35
JLED1: RGB LED connector	36
JSP1: S/PDIF-Out connector	36

JBAT1: Clear CMOS (Reset BIOS) Jumper	37
EZ Debug LED: Debug LED indicators	37
BIOS Setup	38
Entering BIOS Setup	38
Resetting BIOS	39
Updating BIOS	39
Overview	40
SETTINGS	41
Advanced	41
Boot	46
Security	46
Save & Exit	47
OC	48
M-FLASH	52
OC PROFILE	53
HARDWARE MONITOR	54
Software Description	55
Installing Windows® 7/ 8.1/ 10	55
Installing Drivers	55
Installing Utilities	55
COMMAND CENTER	56
LIVE UPDATE 6	60
GAMING APP	62
USB SPEED UP	67
GAMING LAN MANAGER	68
Nahimic 2	70
SteelSeries Engine 3	74
DRAGON EYE	76
RAID Configuration	77
Using RAID Option ROM	77
Installing RAID Driver	83
Installing Operating System on 2.2TB RAID	84
Troubleshooting	89
Regulatory Notices	90

Specifications

CPU	Supports AMD® FX™ / Phenom™ / Athlon™II/ Sempron™ processors for Socket AM3/ AM3+
Chipset	AMD® 970 & SB950 Chipset
Memory	<ul style="list-style-type: none"> • 4x DDR3 memory slots, support up to 32GB <ul style="list-style-type: none"> ▪ Supports DDR3 1066/ 1333/ 1600/ 1866/ 2133(OC) MHz • Dual channel memory architecture
Expansion Slots	<ul style="list-style-type: none"> • 2x PCIe 2.0 x16 slots (support x16/x0, x8/x8 mode) • 3x PCIe 2.0 x1 slots • 1x PCI slot
Multi-GPU	<ul style="list-style-type: none"> • Supports 2-Way AMD® CrossFire™ Technology • Supports 2-Way NVIDIA® SLI™ Technology
Storage	<p>AMD® SB950 Chipset</p> <ul style="list-style-type: none"> • 6x SATA 6Gb/s ports <ul style="list-style-type: none"> ▪ Supports RAID 0, RAID 1, RAID 5 and RAID 10 for SATA storage devices • 1x M.2 slot (Key M)* <ul style="list-style-type: none"> ▪ Supports PCIe 2.0 x2 or x4 and SATA 6Gb/s** ▪ Supports 2242/ 2260 /2280 storage devices <p>* M.2 and SATA ports maximum support 1x M.2_PCLE + 6x SATAs or 1x M.2_SATA + 5x SATAs. Please refer to page 30 for M.2/ SATA ports & PCIe slots combination table.</p> <p>** When inserted M.2_PCLE of x4, PCI_E3 & PCI_E4 can not be used. ** When inserted M.2_PCLE of x2, PCI_E3 & PCI_E4 can be used.</p>
USB	<ul style="list-style-type: none"> • ASMedia® ASM1143 Chipset <ul style="list-style-type: none"> ▪ 2x USB 3.1 Gen2 (SuperSpeed USB 10Gbps) ports (1 Type-A port and 1 Type-C port on the back panel) • ASMedia® ASM1143 Chipset <ul style="list-style-type: none"> ▪ 4x USB 3.1 Gen1 (SuperSpeed USB) ports available through the internal USB 3.1 Gen1 connectors • AMD® SB950 Chipset <ul style="list-style-type: none"> ▪ 14x USB 2.0 (High-speed USB) ports (8 ports on the back panel, 6 ports available through the internal USB connector)
Audio	<ul style="list-style-type: none"> • Realtek® ALC1150 Codec • 7.1-Channel High Definition Audio • Supports S/PDIF output
LAN	1x Intel I211-AT Gigabit LAN controller

Continued on next page

Continued from previous page

Back Panel Connectors	<ul style="list-style-type: none">• 1x PS/2 keyboard/ mouse combo port• 8x USB 2.0 ports• 1x USB 3.1 Gen2 Type-A port• 1x USB 3.1 Gen2 Type-C port• 1x LAN (RJ45) port• 1x optical S/PDIF OUT connector• 6x audio jacks
Internal Connectors	<ul style="list-style-type: none">• 1x 24-pin ATX main power connector• 1x 8-pin ATX 12V power connector• 6x SATA 6Gb/s connectors• 3x USB 2.0 connectors (supports additional 6 USB 2.0 ports)• 2x USB 3.1 Gen1 connectors (supports additional 4 USB 3.1 Gen1 ports)• 1x 4-pin CPU fan connector• 2x 4-pin system fan connectors• 2x 3-pin system fan connectors• 1x Front panel audio connector• 2x Front panel connectors• 1x TPM module connector• 1x Chassis Intrusion connector• 1x Serial port connector• 1x S/PDIF OUT connector• 1x RGB LED connector• 1x Clear CMOS jumper
I/O Controller	FINTEK F71878AD Controller Chip
Form Factor	<ul style="list-style-type: none">• ATX Form Factor• 12 in. x 9.6 in. (30.5 cm x 24.3 cm)

Continued on next page

Continued from previous page

Software	<ul style="list-style-type: none">• Drivers• COMMAND CENTER• LIVE UPDATE 6• FAST BOOT• SUPER CHARGER• GAMING APP• USB SPEED UP• GAMING LAN MANAGER• Nahimic 2• Open Broadcaster Software• Norton™ Internet Security Solution• Google Chrome™ ,Google Toolbar, Google Drive• SteelSeries Engine 3• DRAGON EYE
----------	---

Continued on next page

Continued from previous page

Enthusiast GAMING
Features

- AUDIO BOOST 3
 - Isolated Audio PCB
 - EMI Shielding
 - Dual Headphone Amplifiers
 - High Quality Audio Capacitors
 - Golden Audio Connectors
- GAME BOOST
 - Easy Overclocking
- GAMING LAN
 - Intel® Gigabit Ethernet
 - GAMING Network Manager power by cFos
 - Electric Wave Surge
- GAMING APP
 - System Mode Switching: OC/Gaming/Silent
 - Gaming Hotkey
 - Gaming Mouse Control
 - Gaming LED Control
- Optimized Thermal Design
 - Heat-pipe Direct Touch Technology
 - Enhanced Choke Thermal Design
- Nahimic 2
 - Sound Tracker
 - HD Audio Recorder 2
 - Expert Mode
 - Sound Effect Equalizer
 - Microphone Noise Reduction
- GAMING CERTIFIED
- WTFast GPN
 - 2-Month Premium License
 - Multi-Server Network Optimization
 - Advanced Lag Spike & Disconnect Reduction

Continued on next page

Continued from previous page

MSI Exclusive Features	<ul style="list-style-type: none">• CLICK BIOS 4<ul style="list-style-type: none">▪ EZ Mode & Advanced Mode Switching▪ Board Explorer▪ Hardware Monitor• MILITARY CLASS 4<ul style="list-style-type: none">▪ Military Class Component▪ Military Class Stability and Reliability<ul style="list-style-type: none">• ESD Protection• EMI Protection• Humidity Protection• Circuit Protection• High Temperature Protection• VGA Armor Slot• COMMAND CENTER<ul style="list-style-type: none">▪ System Monitor▪ Smart Fan Control• EZ Debug LED• LIVE UPDATE 6• USB Redrivers• Steel Series Engine 3• SUPER CHARGER
Specification Highlights	<ul style="list-style-type: none">• USB 3.1 Gen2 Type-A/ Type-C Ready• NVMe / AHCI Driver Support• RGB LED pin header

Block Diagram

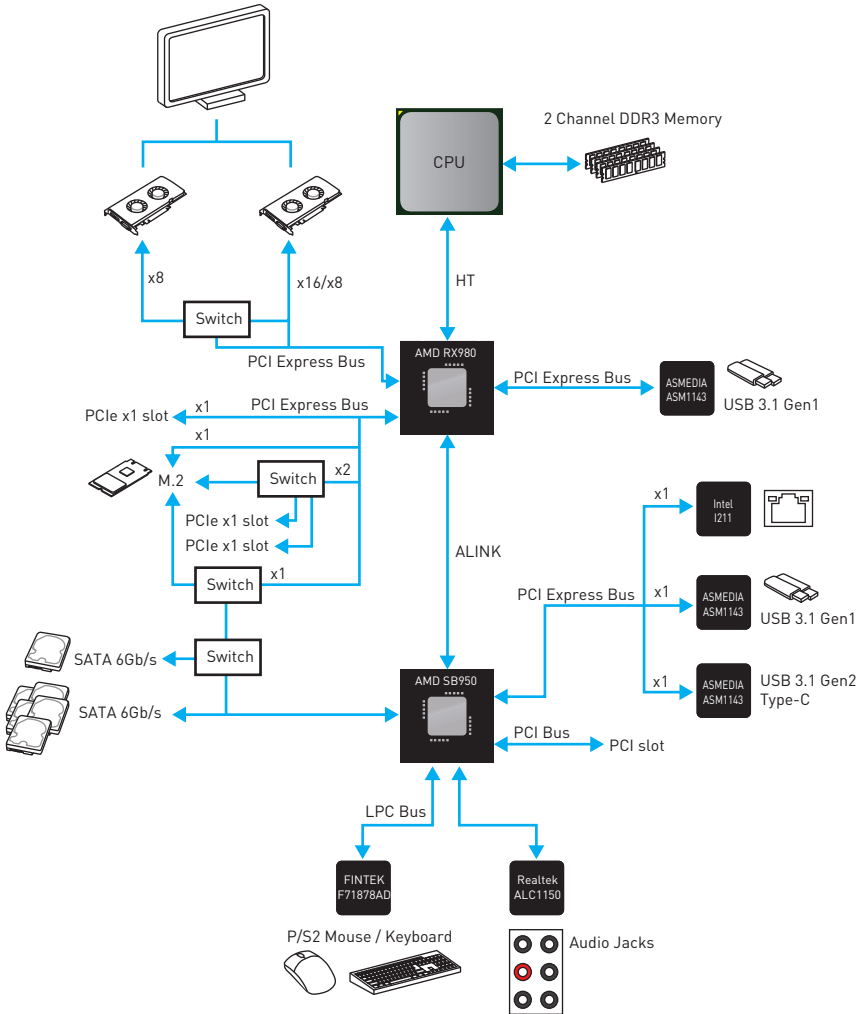

Rear I/O Panel

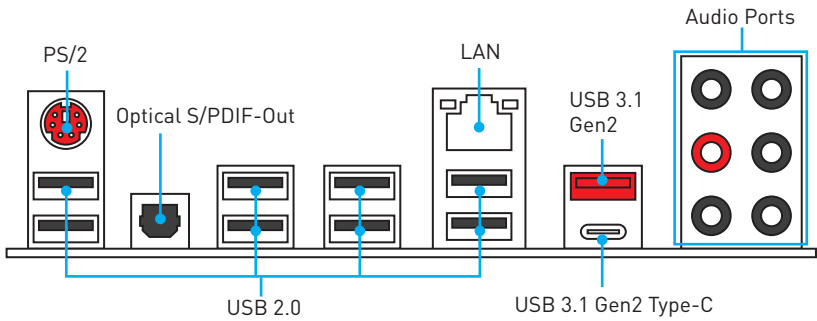

LAN Port LED Status Table

Link/ Activity LED	
Status	Description
Off	No link
Yellow	Linked
Blinking	Data activity

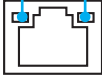

Speed LED	
Status	Description
Off	10 Mbps connection
Green	100 Mbps connection
Orange	1 Gbps connection

Audio Ports Configuration

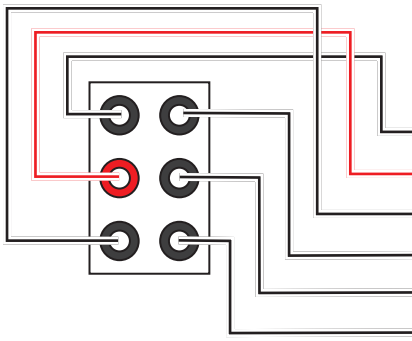

Audio Ports	Channel			
	2	4	6	8
Line-In				
Line-Out/ Front Speaker Out	●	●	●	●
Mic In				
Rear Speaker Out		●	●	●
Center/ Subwoofer Out			●	●
Side Speaker Out				●

(●: connected, **Blank**: empty)

Realtek HD Audio Manager

After installing the **Realtek HD Audio** driver, the **Realtek HD Audio Manager** icon will appear in the system tray. Double click on the icon to launch.



- **Device Selection** - allows you to select a audio output source to change the related options. The **check** sign indicates the devices as default.
- **Application Enhancement** - the array of options will provide you a complete guidance of anticipated sound effect for both output and input device.
- **Main Volume** - controls the volume or balance the right/left side of the speakers that you plugged in front or rear panel by adjust the bar.
- **Profiles** - toggles between profiles.
- **Advanced Settings** - provides the mechanism to deal with 2 independent audio streams.
- **Jack Status** - depicts all render and capture devices currently connected with your computer.
- **Connector Settings** - configures the connection settings.

Auto popup dialog

When you plug into a device at an audio jack, a dialogue window will pop up asking you which device is current connected.

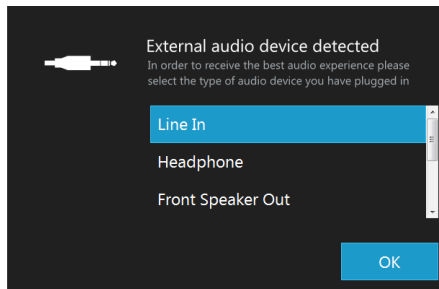

Each jack corresponds to its default setting as shown on the next page.

Audio jacks to headphone and microphone diagram

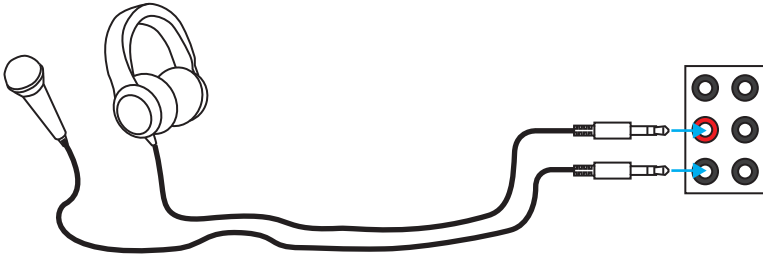

Audio jacks to stereo speakers diagram

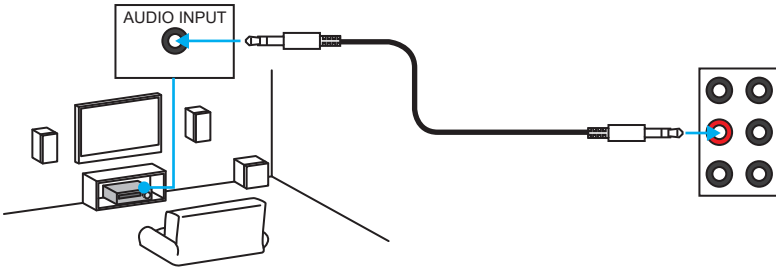

Audio jacks to 7.1-channel speakers diagram

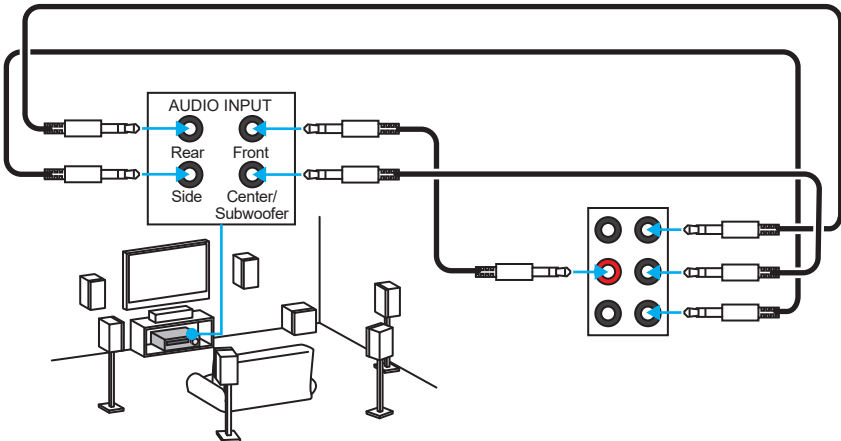

Overview of Components

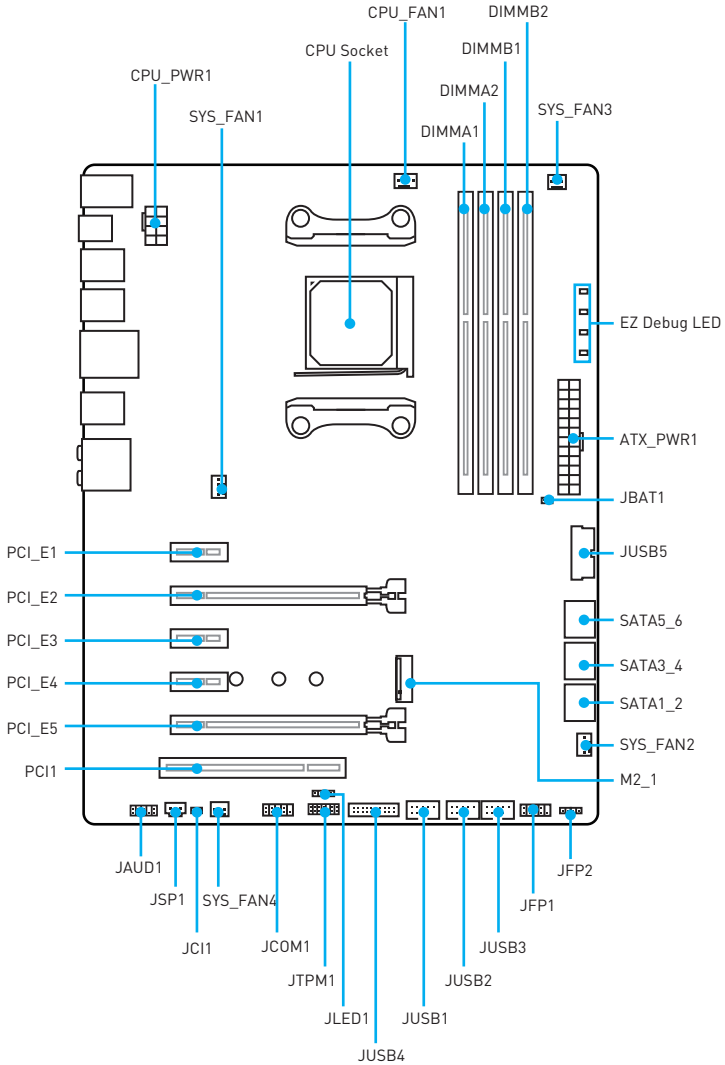

Component Contents

Port Name	Port Type	Page
CPU_FAN1, SYS_FAN1~4	Fan Connectors	34
CPU_PWR1, ATX_PWR1	Power Connectors	31
CPU Socket	AM3/ AM3+	26
DIMMA1~2, DIMMB1~2	DIMM Slots	27
EZ Debug LED	Debug LED indicators	37
JAUD1	Front Audio Connector	35
JBAT1	Clear CMOS (Reset BIOS) Jumper	37
JCI1	Chassis Intrusion Connector	35
JCOM1	Serial Port Connector	31
JFP1, JFP2	Front Panel Connectors	32
JLED1	RGB LED connector	36
JSP1	S/PDIF-Out connector	36
JTPM1	TPM Module Connector	33
JUSB1~3	USB 2.0 Connectors	33
JUSB4~5	USB 3.1 Gen1 Connectors	32
M2_1	M.2 Slot	29
PCI_E1~5, PCI1	PCIe/ PCI Expansion Slots	28
SATA1~6	SATA 6Gb/s Connectors	30

CPU Socket

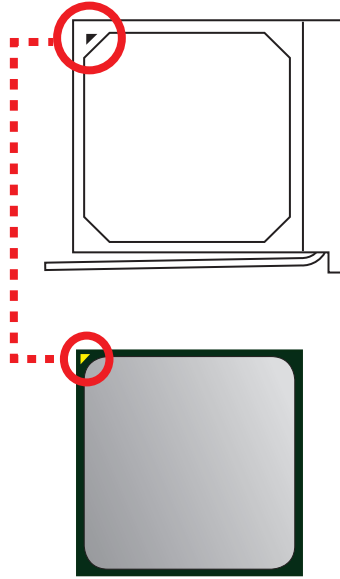
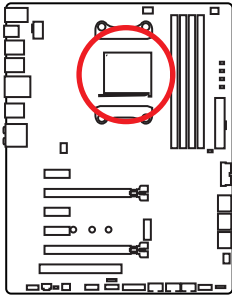

Introduction to the AM3/ AM3+ CPU

The surface of the AM3/ AM3+ CPU has a yellow triangle to assist in correctly lining up the CPU for motherboard placement. The yellow triangle is the Pin 1 indicator.

WARNING

If you plan to use the water-cooling kit, please note that the heavy water-cooling device will cause the motherboard to be bent and damaged.

Important

- Always unplug the power cord from the power outlet before installing or removing the CPU.
- Please retain the CPU protective cap after installing the processor. MSI will deal with Return Merchandise Authorization (RMA) requests if only the motherboard comes with the protective cap on the CPU socket.
- When installing a CPU, always remember to install a CPU heatsink. A CPU heatsink is necessary to prevent overheating and maintain system stability.
- Confirm that the CPU heatsink has formed a tight seal with the CPU before booting your system.
- Overheating can seriously damage the CPU and motherboard. Always make sure the cooling fans work properly to protect the CPU from overheating. Be sure to apply an even layer of thermal paste (or thermal tape) between the CPU and the heatsink to enhance heat dissipation.
- If you purchased a separate CPU and heatsink/ cooler, Please refer to the documentation in the heatsink/ cooler package for more details about installation.
- This motherboard is designed to support overclocking. Before attempting to overclock, please make sure that all other system components can tolerate overclocking. Any attempt to operate beyond product specifications is not recommended. MSI® does not guarantee the damages or risks caused by inadequate operation beyond product specifications.

DIMM Slots

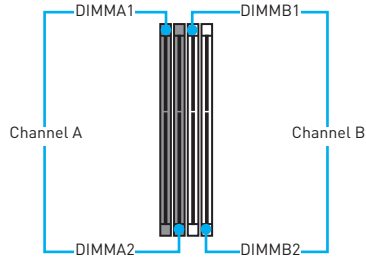
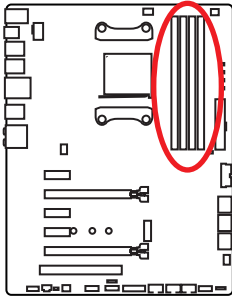

Memory module installation recommendation

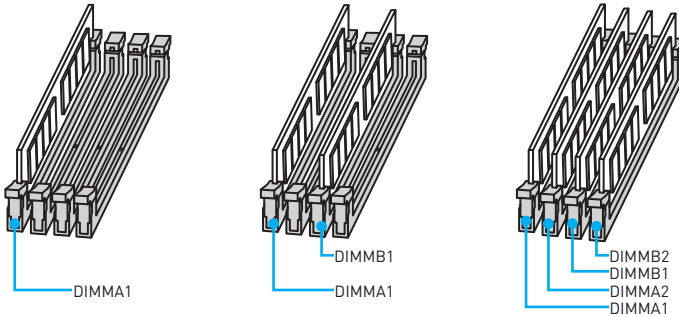

Important

- Always insert memory modules in the DIMMA1 slot first.
- Due to chipset resource usage, the available capacity of memory will be a little less than the amount of installed.
- Please note that the maximum capacity of addressable memory is 4GB or less for 32-bit Windows OS due to the memory address limitation. Therefore, we recommended that you to install 64-bit Windows OS if you want to install more than 4GB memory on the motherboard.
- It is recommended to use a more efficient memory cooling system for full DIMMs installation or overclocking.
- The stability and compatibility of installed memory module depend on installed CPU and devices when overclocking.

PCI_E1~5, PCI1: PCIe/ PCI Expansion Slots

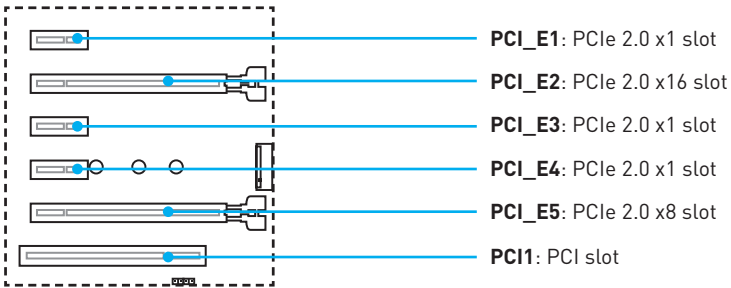

Multiple graphics cards installation recommendation

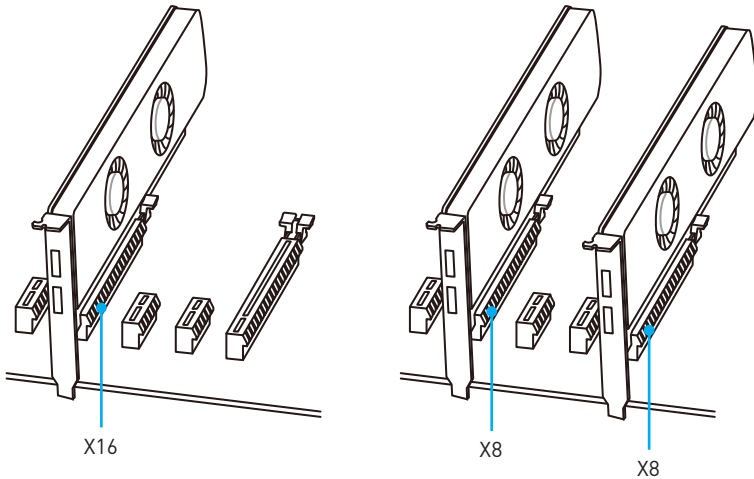

Important

- For a single PCIe x16 expansion card installation with optimum performance, using the PCI_E2 slot is recommended.
- When adding or removing expansion cards, always turn off the power supply and unplug the power supply power cable from the power outlet. Read the expansion card's documentation to check for any necessary additional hardware or software changes.
- If you install a large and heavy graphics card, you need to use a tool such as **MSI Gaming Series Graphics Card Bolster** to support its weight and to prevent deformation of the slot.

M2_1: M.2 Slot

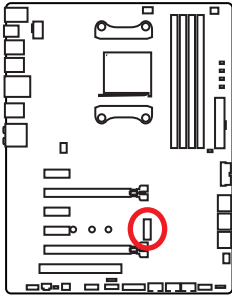

Important

Intel® RST only supports PCIe M.2 SSD with UEFI ROM, does not support Legacy ROM.

Installing M.2 module

1. Remove the screw from the base screw.
2. Remove the base screw.

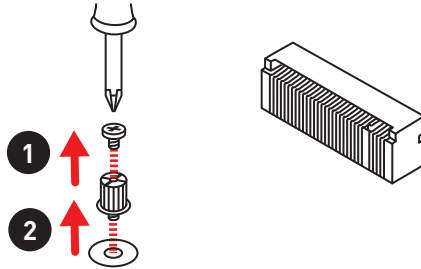

3. Tighten the base screw into the hole of the distance to the M.2 slot as the length your M.2 module.
4. Insert your M.2 module into the M.2 slot at a 30-degree angle.

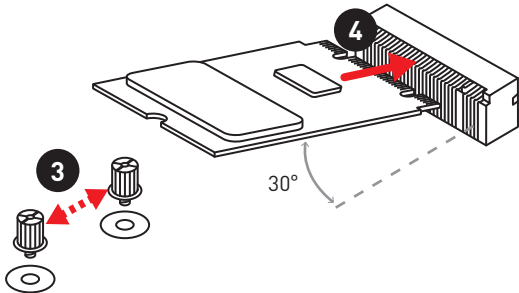

5. Put the screw in the notch on the trailing edge of your M.2 module and tighten it into the base screw.

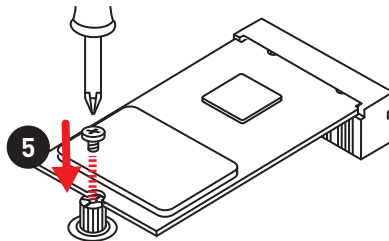

SATA1~6: SATA 6Gb/s Connectors

These connectors are SATA 6Gb/s interface ports. Each connector can connect to one SATA device.

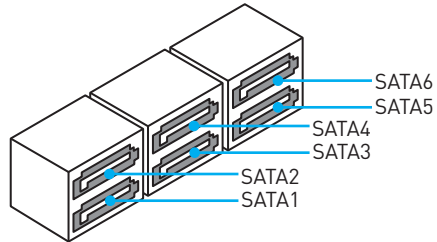
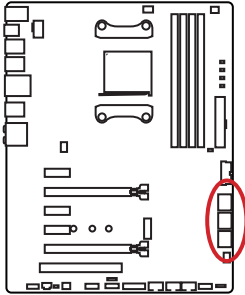

Important

- Please do not fold the SATA cable at a 90-degree angle. Data loss may result during transmission otherwise.
- SATA cables have identical plugs on either sides of the cable. However, it is recommended that the flat connector be connected to the motherboard for space saving purposes.

M.2/ SATA ports & PCIe slots combination table

Slot	Available SATA/ SATAe connectors		
	PCIe x2	PCIe x4	SATA
M2_1	PCIe x2	PCIe x4	SATA
SATA1	✓	✓	✓
SATA2	✓	✓	✓
SATA3	✓	✓	✓
SATA4	✓	✓	✓
SATA5	✓	✓	✓
SATA6	✓	✓	—
PCI_E3	✓	—	✓
PCI_E4	✓	—	✓

[**SATA**: M.2 SATA SSD, **PCIe x2**: M.2 PCIe x2 SSD, **PCIe x4**: M.2 PCIe x4 SSD, ✓: available, —: unavailable]

CPU_PWR1, ATX_PWR1: Power Connectors

These connectors allow you to connect an ATX power supply.

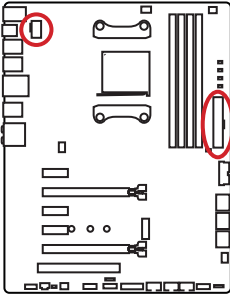

1	Ground	5	+12V
2	Ground	6	+12V
3	Ground	7	+12V
4	Ground	8	+12V

1	+3.3V	13	+3.3V
2	+3.3V	14	-12V
3	Ground	15	Ground
4	+5V	16	PS-ON#
5	Ground	17	Ground
6	+5V	18	Ground
7	Ground	19	Ground
8	PWR OK	20	Res
9	5VSB	21	+5V
10	+12V	22	+5V
11	+12V	23	+5V
12	+3.3V	24	Ground

Important

Make sure that all the power cables are securely connected to a proper ATX power supply to ensure stable operation of the motherboard.

JCOM1: Serial Port Connector

This connector allows you to connect the optional serial port with bracket.

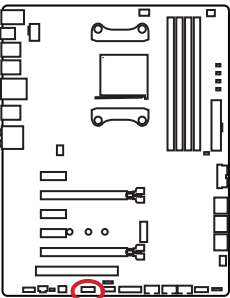

1	DCD	2	SIN
3	SOUT	4	DTR
5	Ground	6	DSR
7	RTS	8	CTS
9	RI	10	No Pin

JUSB4~5: USB 3.1 Gen1 Connectors

These connectors allow you to connect USB 3.1 Gen1 ports on the front panel.

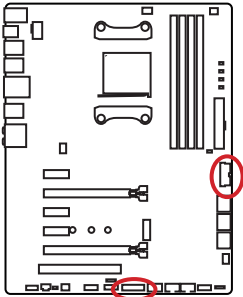

<p>JUSB4</p>		<p>JUSB5</p>	
1	Power	11	USB2.0+
2	USB3_RX_DN	12	USB2.0-
3	USB3_RX_DP	13	Ground
4	Ground	14	USB3_TX_C_DP
5	USB3_TX_C_DN	15	USB3_TX_C_DN
6	USB3_TX_C_DP	16	Ground
7	Ground	17	USB3_RX_DP
8	USB2.0-	18	USB3_RX_DN
9	USB2.0+	19	Power
10	Ground	20	No Pin

Important

Note that the Power and Ground pins must be connected correctly to avoid possible damage.

JFP1, JFP2: Front Panel Connectors

These connectors connect to the switches and LEDs on the front panel.

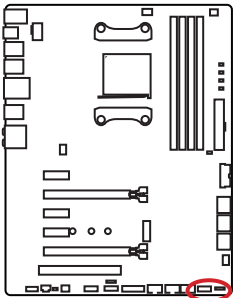

<p>JFP1</p>			
1	HDD LED +	2	Power LED +
3	HDD LED -	4	Power LED -
5	Reset Switch	6	Power Switch
7	Reset Switch	8	Power Switch
9	Reserved	10	No Pin

<p>JFP2</p>		1	Speaker -	2	Buzzer +
		3	Buzzer -	4	Speaker +

JUSB1~3: USB 2.0 Connectors

These connectors allow you to connect USB 2.0 ports on the front panel.

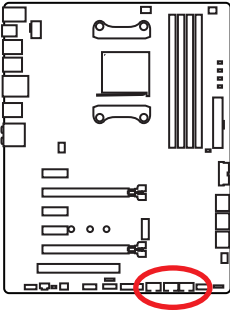

1	VCC	2	VCC
3	USB0-	4	USB1-
5	USB0+	6	USB1+
7	Ground	8	Ground
9	No Pin	10	NC

Important

- Note that the VCC and Ground pins must be connected correctly to avoid possible damage.
- In order to recharge your iPad, iPhone and iPod through USB ports, please install MSI® SUPER CHARGER utility.

JTPM1: TPM Module Connector

This connector is for TPM (Trusted Platform Module). Please refer to the TPM security platform manual for more details and usages.

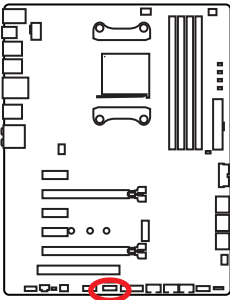

1	LPC Clock	2	3V Standby power
3	LPC Reset	4	3.3V Power
5	LPC address & data pin0	6	Serial IRQ
7	LPC address & data pin1	8	5V Power
9	LPC address & data pin2	10	No Pin
11	LPC address & data pin3	12	Ground
13	LPC Frame	14	Ground

CPU_FAN1, SYS_FAN1~4: Fan Connectors

Fan connectors can be classified as PWM (Pulse Width Modulation) Mode and Voltage Mode. PWM Mode fan connectors provide constant 12V output and adjust fan speed with speed control signal. Voltage Mode fan connectors control fan speed by changing voltage. Therefore, when you plug a 3-pin (Non-PWM) fan to a PWM Mode fan connector, the fan speed will be always maintained at 100%, and that could be noisy.

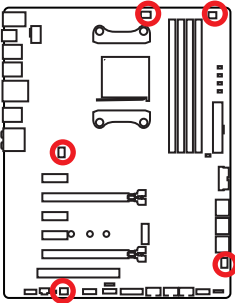

PWM Mode fan connector

 CPU_FAN1			
1	Ground	2	+12V
3	Sense	4	Speed Control Signal

Voltage Mode fan connector

 SYS_FAN1/ SYS_FAN2			
1	Ground	2	Voltage Control
3	Sense	4	NC

 SYS_FAN3/ SYS_FAN4			
1	Ground	2	+12V
3	NC		

Controlling the fan speed

There are two ways to manage fan speed. One is to go to **BIOS > HARDWARE MONITOR**. The other is to use **COMMAND CENTER** application.

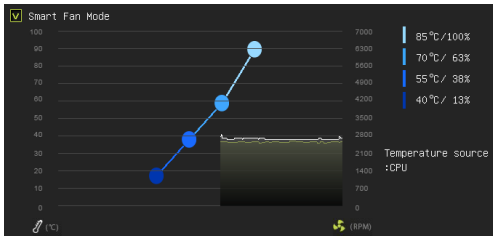

BIOS > HARDWARE MONITOR

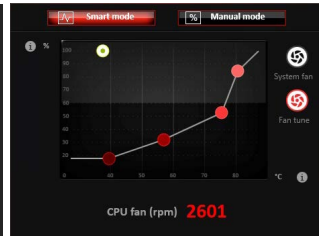

COMMAND CENTER

Both methods offer gradient points of the fan speed that allow you to adjust fan speed in relation to CPU temperature.

JAUD1: Front Audio Connector

This connector allows you to connect audio jacks on the front panel.

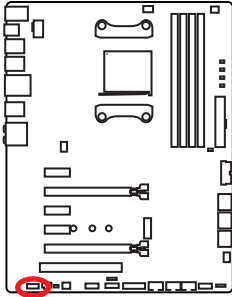

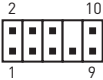
			
1	MIC L	2	Ground
3	MIC R	4	NC
5	Head Phone R	6	MIC Detection
7	SENSE_SEND	8	No Pin
9	Head Phone L	10	Head Phone Detection

JCI1: Chassis Intrusion Connector

This connector allows you to connect the chassis intrusion switch cable.

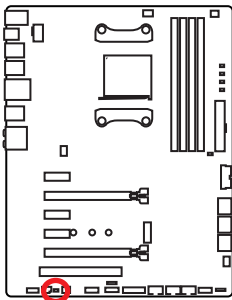

Normal
(default)



Trigger the chassis
intrusion event

Using chassis intrusion detector

1. Connect the **JCI1** connector to the chassis intrusion switch/ sensor on the chassis.
2. Close the chassis cover.
3. Go to **BIOS > Settings > Security > Chassis Intrusion Configuration**.
4. Set **Chassis Intrusion** to **Enabled**.
5. Press **F10** to save and exit and then press the **Enter** key to select **Yes**.
6. Once the chassis cover is opened again, a warning message will be displayed on screen when the computer is turned on.

Resetting the chassis intrusion warning

1. Go to **BIOS > Settings > Security > Chassis Intrusion Configuration**.
2. Set **Chassis Intrusion** to **Reset**.
3. Press **F10** to save and exit and then press the **Enter** key to select **Yes**.

JLED1: RGB LED connector

This connector allows you to connect the RGB LED strip.

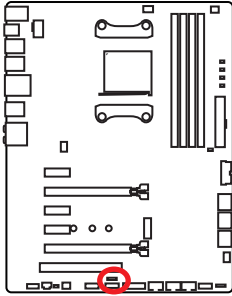

1			
1	+12V	2	G
3	R	4	B

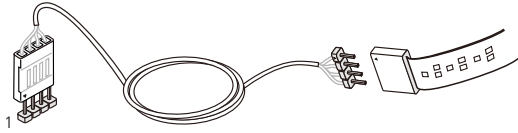

Important

- This connector supports 5050 RGB multi-color LED strips (12V/G/R/B) within 2 meters.
- Always turn off the power supply and unplug the power cord from the power outlet before installing or removing the RGB LED strip.
- Please use the **LED Effect** of GAMING APP to adjust, calibrate and control the LED light, refer to the Software section for details.

JSP1: S/PDIF-Out connector

This connector allows you to connect the S/PDIF interface for digital audio transmission.

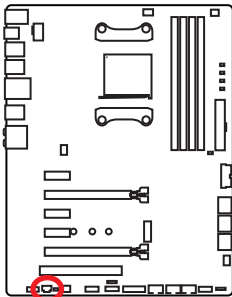

1			
1	GND	2	SPDIF
3	VCC		

JBAT1: Clear CMOS (Reset BIOS) Jumper

There is CMOS memory onboard that is external powered from a battery located on the motherboard to save system configuration data. If you want to clear the system configuration, set the jumpers to clear the CMOS memory.

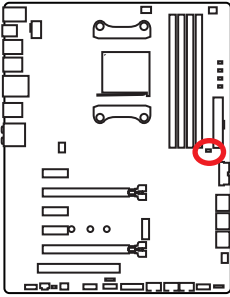

Keep Data
(default)



Clear CMOS/
Reset BIOS

Resetting BIOS to default values

1. Power off the computer and unplug the power cord
2. Use a jumper cap to short JBAT1 for about 5-10 seconds.
3. Remove the jumper cap from JBAT1.
4. Plug the power cord and power on the computer.

EZ Debug LED: Debug LED indicators

These LEDs indicate the status of the motherboard.

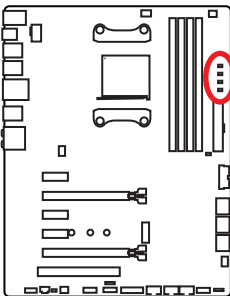

- CPU** - indicates CPU is not detected or fail.*
- DRAM** - indicates DRAM is not detected or fail.
- VGA** - indicates GPU is not detected or fail.
- BOOT** - indicates the booting device is not detected or fail.



Important

* All EZ Debug LEDs (include CPU, DRAM, VGA & BOOT) will light up simultaneously while the CPU is not detected or fail.

BIOS Setup

The default settings offer the optimal performance for system stability in normal conditions. You should **always keep the default settings** to avoid possible system damage or failure booting unless you are familiar with BIOS.

Important

- BIOS items are continuously update for better system performance. Therefore, the description may be slightly different from the latest BIOS and should be for reference only. You could also refer to the **HELP** information panel for BIOS item description.
- The pictures in this chapter are for reference only and may vary from the product you purchased.

Entering BIOS Setup

Please refer the following methods to enter BIOS setup.

- Press **Delete** key, when the **Press DEL key to enter Setup Menu, F11 to enter Boot Menu** message appears on the screen during the boot process.
- Use **MSI FAST BOOT** application. Click on **G02BIOS** button and choose **OK**. The system will reboot and enter BIOS setup directly.



Click on **G02BIOS**

Function key

Key	Function
F1	General Help
F4	Enter CPU Specifications menu
F5	Enter Memory-Z menu
F6	Load optimized defaults
F8	Load Overclocking Profile from USB flash drive
F9	Save Overclocking Profile to USB flash drive
F10	Save Change and Reset
F12	Save a screenshot to a FAT/ FAT 32 USB flash drive

Resetting BIOS

You might need to restore the default BIOS setting to solve certain problems. There are several ways to reset BIOS:

- Go to BIOS and press **F6** to load optimized defaults.
- Short the **Clear CMOS** jumper on the motherboard.



Important

Please refer to the **Clear CMOS jumper** section for resetting BIOS.

Updating BIOS

Updating BIOS with M-FLASH

Before updating:

Please download the latest BIOS file that matches your motherboard model from MSI website. And then save the BIOS file into the USB flash drive.

Updating BIOS:

1. Press Del key to enter the BIOS Setup during POST.
2. Insert the USB flash drive that contains the update file into the computer.
3. Go to **BIOS > M-FLASH > Update BIOS > Select one file to update BIOS**, select a BIOS file to perform the BIOS update process.
4. After the flashing process is 100% completed, the system will reboot automatically.

Updating the BIOS with Live Update 6

Before updating:

Make sure the LAN driver is already installed and the internet connection is set properly.

Updating BIOS:

1. Install and launch MSI LIVE UPDATE 6.
2. Select **Manual scan**.
3. Check **MB BIOS** box and click on **Scan** button.
4. Select the **MB BIOS** and click on  icon to download and install the latest BIOS file.
5. Click **Next** and choose **In Windows mode**. And then click **Next** and **Start** to start updating BIOS.
6. After the flashing process is 100% completed, the system will restart automatically.

Overview

After entering BIOS, the following screen is displayed.

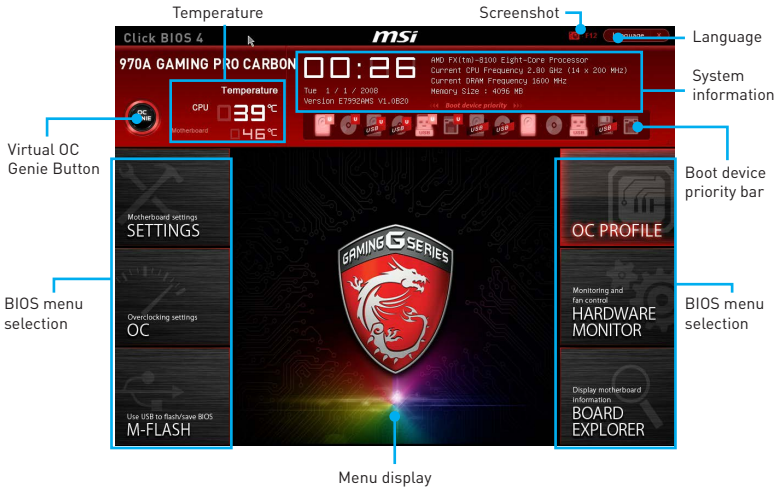

- **BIOS menu selection** - the following options are available:
 - **SETTINGS** - allows you to specify the parameters for chipset and boot devices.
 - **OC** - contains the frequency and voltage adjustments. Increasing the frequency may get better performance.
 - **M-FLASH** - provides the way to update BIOS with a USB flash drive.
 - **OC PROFILE** - allows you to manage overclocking profiles.
 - **HARDWARE MONITOR** - allows you to set the speeds of fans and monitor voltages of system.
 - **BOARD EXPLORER** - provides the information of installed devices on this motherboard.
- **Virtual OC Genie Button** - enables or disables the **OC Genie** function by clicking on this button. When enabled, this button will be light. Enabling **OC Genie** function can automatically overclock with MSI optimized overclocking profile.

Important

We recommend that you do not to make any modification in OC menu mode and do not to load defaults after enabling the OC Genie function.

- **Menu display** - provides BIOS setting items and information to be configured.
- **Boot device priority bar** - you can move the device icons to change the boot priority. The boot priority from high to low is left to right.
- **System Information** - shows the time, date, CPU name, CPU frequency, DRAM frequency, DRAM capacity and the BIOS version.
- **Language** - allows you to select the language of the BIOS setup.
- **Screenshot** - press this tab or the F12 key to take a screenshot and save it to USB flash drive (FAT/ FAT32 format only).
- **Temperature** - shows the temperatures of processor and the motherboard.

SETTINGS



System Status

► System Date

Sets the system date. Use tab key to switch between date elements.

The format is <day> <month> <date> <year>.

- <day> Day of the week, from Sun to Sat, determined by BIOS. Read-only.
- <month> The month from Jan. through Dec.
- <date> The date from 1 to 31 can be keyed by numeric function keys.
- <year> The year can be adjusted by users.

► System Time

Sets the system time. Use tab key to switch between time elements.

The time format is <hour> <minute> <second>.

► SATA PortX

Shows the information of connected SATA device.



Important

If the connected SATA device is not displayed, turn off computer and re-check SATA cable and power cable connections of the device and motherboard.

► System Information

Shows detailed system information, including CPU type, BIOS version, and Memory (read only).

► DMI Information

Shows system information, desktop Board Information and chassis Information. (Read only).

Advanced

► PCI Subsystem Settings

Sets PCI, PCI express interface protocol and latency timer. Press **Enter** to enter the sub-menu.

▶ **PCI Latency Timer [32]**

Sets latency timer of PCI interface device.

[Options: 32, 64, 96, 128, 160, 192, 224, 248 PCI Bus clocks]

▶ **ACPI Settings**

Sets ACPI parameters of onboard power LED behaviors. Press **Enter** to enter the sub-menu.

▶ **ACPI Standby State**

Specifies the power saving modes for ACPI function.

▶ **Power LED [Blinking]**

Sets shining behaviors of the onboard Power LED.

[Dual Color] The power LED turns to another color to indicate the S3 state.

[Blinking] The power LED blinks to indicate the S3 state.

▶ **Integrated Peripherals**

Sets integrated peripherals' parameters, such as LAN, HDD, USB and audio. Press **Enter** to enter the sub-menu.

▶ **Onboard LAN Controller [Enabled]**

Enables or disables the onboard LAN controller.

▶ **LAN Option ROM [Disabled]**

Enables or disables the legacy network Boot Option ROM for detailed settings. This item will appear when **Onboard LAN Controller** is enabled.

[Enabled] Enables the onboard LAN Boot ROM.

[Disabled] Disables the onboard LAN Boot ROM.

▶ **Network Stack [Disabled]**

Sets UEFI network stack for optimizing IPv4 / IPv6 function.

[Enabled] Enables UEFI network stack.

[Disabled] Disables UEFI network stack.

▶ **Ipv4 PXE Support [Enabled]**

When **Enabled**, the system UEFI network stack will support Ipv4 protocol. This item will appear when **Network Stack** is enabled.

[Enabled] Enables the Ipv4 PXE boot support.

[Disabled] Disables the Ipv4 PXE boot support.

▶ **Ipv6 PXE Support [Enabled]**

When **Enabled**, the system UEFI network stack will support Ipv6 protocol. This item will appear when **Network Stack** is enabled.

[Enabled] Enables the Ipv6 PXE boot support.

[Disabled] Disables the Ipv6 PXE boot support.

▶ **SATA Mode [AHCI Mode]**

Sets the operation mode of the onboard SATA controller.

[AHCI Mode] Specify the AHCI mode for SATA storage devices. AHCI (Advanced Host Controller Interface) offers some advanced features to enhance the speed and performance of SATA storage device, such as Native Command Queuing (NCQ) and hot-plugging.

[RAID Mode] Enables RAID function for SATA storage devices.

▶ **SATAx Hot Plug [Disabled]**

Allows user to enable or disable the SATA hot plug support.

[Enabled] Enables hot plug support for the SATA ports.

[Disabled] Disables hot plug support for the SATA ports.

▶ **HD Audio Controller [Enabled]**

Enables or disables the onboard High Definition Audio controller.

▶ **HPET [Enabled]**

Enables or disables the HPET (High Precision Event Timers) support.

▶ **USB Configuration**

Sets the onboard USB controller and device function. Press <Enter> to enter the sub-menu.

▶ **USB Controller [Enabled]**

Enables or disables all USB controller.

▶ **XHCI Hand-off [Enabled]**

Enables or disables XHCI hand-off support for the operating system without XHCI hand-off feature. This item will appear when **USB Controller** is enabled.

▶ **EHCI Hand-off [Enabled]**

Enables or disables EHCI hand-off support for the operating system without EHCI hand-off feature.

▶ **Legacy USB Support [Enabled]**

Sets Legacy USB function support.

[Auto] The system will automatically detect if any USB device is connected and enable the legacy USB support.

[Enabled] Enable the USB support under legacy mode.

[Disabled] The USB devices will be unavailable under legacy mode.

▶ **Onboard USB 3.0 Controller [Enabled]**

Enables or disables the external USB 3.0 controller.

▶ **Super IO Configuration**

Sets system Super I/O chip parameters including LPT and COM ports. Press **Enter** to enter the sub-menu.

▶ **Serial (COM) Port 0 Configuration**

Sets detailed configuration of serial(COM) port x. Press <Enter> to enter the sub-menu.

▶ **Serial (COM) Port 0 [Enabled]**

Enables or disables serial (COM) port x.

▶ **Serial (COM) Port 0 Settings [Auto]**

Sets serial port x (COM). If set to Auto, BIOS will optimize the IRQ automatically or you can set it manually.

▶ **Power Management Setup**

Sets system Power Management of EuP2013 and AC Power Loss behaviors. Press **Enter** to enter the sub-menu.

▶ **EuP 2013 [Disabled]**

Enables or disables the system power consumption according to EuP2013 regulation. When **enabled**, the system will not support RTC wake up event functions.

[Enabled] Optimize the system power consumption according to EuP 2013 regulation. It will not support S4 & S5 wake up by USB and PCIe devices.

[Disabled] Disables this function.

▶ **Restore after AC Power Loss [Power Off]**

Sets the system behaviors while encountering the AC power loss.

[Power Off] Leaves the system in power off state after restoring AC power.

[Power On] Boot up the system after restoring AC power.

[Last State] Restores the system to the previous state (power on/ power off) before AC power loss.

▶ **Windows 8 Configuration**

Sets Windows 8/ 8.1 detailed configuration and behaviors. Press <Enter> to enter the sub-menu.

▶ **Windows 8 Feature [Disabled]**

Enables the supports for Windows 8/ 8.1 or disables for other operating systems. Before enabling this item, make sure all installed devices & utilities (hardware & software) should meet the Windows 8/ 8.1 requirements.

[Enabled] The system will switch to UEFI mode to meet the Windows 8 requirement.

[Disabled] Disables this function.

▶ **MSI Fast Boot [Disabled]**

MSI Fast Boot is the fastest way to boot the system. It will disable more devices to speed up system boot time which is faster than the boot time of **Fast Boot**.

[Enabled] Enables the MSI Fast Boot function to speed up booting time. And the following **Fast Boot** field will be disabled and fixed.

[Disabled] Disables MSI Fast Boot.

 **Important**

When MSI Fast Boot is enabled, you can use **MSI FAST BOOT** application to enter BIOS setup if needed. Please refer **Entering BIOS Setup** section for details.

▶ **Fast Boot [Disabled]**

Enables or disables the fast boot feature for Windows 8/ 8.1. This item will only be available when **MSI Fast Boot** is disabled.

[Enabled] Enables the Fast Boot configuration to accelerate system boot time.

[Disabled] Disables the Fast Boot configuration.

▶ **Wake Up Event Setup**

Sets system wake up behaviors for different sleep modes. Press <Enter> to enter the sub-menu.

▶ **Wake Up Event By [BIOS]**

Selects the wake up event by BIOS or operating system.

[BIOS] Activates the following items, set wake up events of these items.

[OS] The wake up events will be defined by OS.

▶ **Resume By RTC Alarm [Disabled]**

Enables or disables the system wake up by RTC Alarm.

[Enabled] Enables the system to boot up on a scheduled time/ date.

[Disabled] Disables this function.

▶ **Date (of month) Alarm/ Time (hh:mm:ss) Alarm**

Sets RTC alarm date/ Time. If Resume By RTC Alarm is set to [Enabled], the system will automatically resume (boot up) on a specified date/hour/minute/second in these fields (using the <+> and <-> to select the date & time settings).

▶ **Resume By PCI-E Device [Disabled]**

Enables or disables the system wake up by PCI-E devices.

[Enabled] Enables the system to be awakened from the power saving modes when activity or input signal of PCI-E device is detected. Note: enables this Item to support **Resume by USB Device** with third party USB port if any.

[Disabled] Disables this function.

▶ **Resume From S3 by USB Device [Disabled]**

Enables or disables the system wake up by USB devices.

[Enabled] Enables the system to be awakened from S3 (suspend to RAM) sleep state when activity of USB device is detected.

[Disabled] Disables this function.

▶ **Resume From S3/S4/S5 by PS/2 Mouse [Disabled]**

Enables or disables the system wake up by PS/2 mouse.

[Enabled] Enables the system to be awakened from S3/ S4/ S5 state when activity of PS/2 mouse is detected.

[Disabled] Disables this function.

▶ **Resume From S3/S4/S5 by PS/2 Keyboard [Disabled]**

Enables or disables the system wake up by PS/2 keyboard.

[Any Key] Enables the system to be awakened from S3/ S4/ S5 state when activity of any key on PS/2 keyboard is detected.

[Hot Key] Enables the system to be awakened from S3/ S4/ S5 state when activity of hot key on PS/2 keyboard is detected.

[Disabled] Disables this function.

Boot

Sets the sequence of system boot devices.

▶ **Full Screen Logo Display [Enabled]**

Enables or disables to show the full screen logo while system POST.

[Enabled] Shows the logo in full screen.

[Disabled] Shows the POST messages.

▶ **Boot Mode Select [LEGACY+UEFI]**

Sets the system boot mode from legacy or UEFI architecture depending on OS installation requirement. This item will become un-selectable and will be configured automatically by BIOS when **Windows 8 Feature** is enabled.

[UEFI] Enables UEFI BIOS boot mode support only.

[LEGACY+UEFI] Enables both Legacy BIOS boot mode and UEFI BIOS boot mode.

▶ **FIXED BOOT ORDER Priorities**

Sets device priority for system boot.

▶ **Boot Option Priorities**

These items are used to prioritize the installed boot devices.

Security

▶ **Administrator Password**

Sets administrator password for system security. User has full rights to change the BIOS items with administrator password. After setting the administrator password, the state of this item will show “Installed”.

▶ **User Password**

Sets User Password for system security. User has limited rights to change the BIOS items with user password. This item will be available when administrator password is set. After setting the user password, the state of this item will show **Installed**.

Important

When selecting the Administrator / User Password items, a password box will appear on the screen. Type the password then press <Enter>. The password typed now will replace any previous set password from CMOS memory. You will be prompted to confirm the password. You may also press <Esc> to abort the selection.

To clear a set password, press <Enter> when you are prompted to enter a new password. A message will confirm the password is being disabled. Once the password is disabled, you can enter the setup and OS without authorization.

▶ **U-Key [Disabled]**

Enables or disables U-Key as user's password to access the system.

▶ **Make U-Key at**

Makes a key at the USB flash drive to prevent other people from accessing the system. Only the user who has the key with the flash drive can access the system.

▶ **Chassis Intrusion Configuration**

Press **Enter** to enter the sub-menu.

▶ **Chassis Intrusion [Disabled]**

Enables or disables recording messages when the chassis is opened. This function is ready for the chassis equips a chassis intrusion switch.

[Enabled] Once the chassis is opened, the system will record and issue a warning message.

[Reset] Clear the warning message. After clearing the message, please return to **Enabled** or **Disabled**.

[Disabled] Disables this function.

Save & Exit

▶ **Discard Changes and Exit**

Exit BIOS setup without saving any change.

▶ **Save Changes and Reboot**

Save all changes and reboot the system.

▶ **Save Changes**

Save current changes.

▶ **Discard Changes**

Discard all changes and restore to the previous values.

▶ **Restore Defaults**

Restore or load all default values.

▶ **Boot Override**

The installed bootable devices will appear on this menu, you can select one of them to be the boot device.

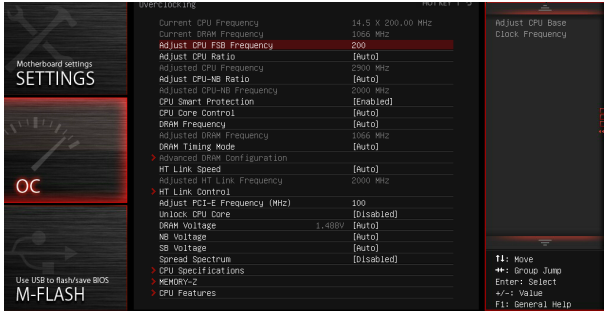

! Important

- *Overclocking your PC manually is only recommended for advanced users.*
- *Overclocking is not guaranteed, and if done improperly, it could void your warranty or severely damage your hardware.*
- *If you are unfamiliar with overclocking, we advise you to use OC Genie function for easy overclocking.*

▶ **Current CPU/ DRAM Frequency**

These items show the current frequencies of installed CPU and Memory. Read-only.

▶ **Adjust CPU FSB Frequency**

Allows you to set the CPU FSB frequency (in MHz). You may overclock the CPU by adjusting this value. Please note that overclocking behavior and stability is not guaranteed.

▶ **Adjust CPU Ratio [Auto]**

Sets the CPU ratio that is used to determine CPU clock speed. This item can only be changed if the processor supports this function.

▶ **Adjusted CPU Frequency**

Shows the adjusted CPU frequency. Read-only.

▶ **Adjust CPU-NB Ratio [Auto]**

Sets the CPU-NB ratio that is used to determine CPU-NB clock speed.

▶ **Adjusted CPU-NB Frequency**

Shows the adjusted CPU frequency. Read-only.

▶ **CPU Smart Protection [Enabled]**

CPU Smart Protection is a mechanism of CPU overheating protection. It will automatically reduce the clock when the CPU temperature gets too high.

▶ CPU Core Control [Auto]

This item allows you to select the number of active processor cores. When set to **Auto**, the CPU will operate under the default number of cores.

▶ DRAM Frequency [Auto]

Sets the DRAM frequency. Please note the overclocking behavior is not guaranteed.

▶ Adjusted DRAM Frequency

Shows the adjusted DRAM frequency. Read-only.

▶ DRAM Timing Mode [Auto]

Selects the memory timing mode.

[Auto] DRAM timings will be determined based on SPD (Serial Presence Detect) of installed memory modules.

[Link] Allows user to configure the DRAM timing manually for all memorychannel.

[UnLink] Allows user to configure the DRAM timing manually for respective memory channel.

▶ Advanced DRAM Configuration

Press **Enter** to enter the sub-menu. This sub-menu will be activated after setting **Link** or **Unlink** in **DRAM Timing Mode**. User can set the memory timing for each memory channel. The system may become unstable or unbootable after changing memory timing. If it occurs, please clear the CMOS data and restore the default settings. (Refer to the **Clear CMOS jumper** section to clear the CMOS data, and enter the BIOS to load the default settings.)

▶ HT Link Speed [Auto]

This item allows you to set the Hyper-Transport Link speed. When **Auto**, the system will detect the HT link speed automatically.

▶ Adjusted HT Link Frequency

It shows the adjusted HT Link frequency. Read-only.

▶ HT Link Control

Press **Enter** to enter the sub-menu.

▶ HT Incoming/ Outgoing Link Width

These items allow you to set the Hyper-Transport Link width. When **Auto**, the system will detect the HT link width automatically.

▶ Adjust PCI-E Frequency (MHz)

Sets the PCI Express frequency.

▶ Unlock CPU Core [Disabled]

This item is used to unlock the CPU core. Please refer to the procedures below for CPU core unlocked in BIOS setup.

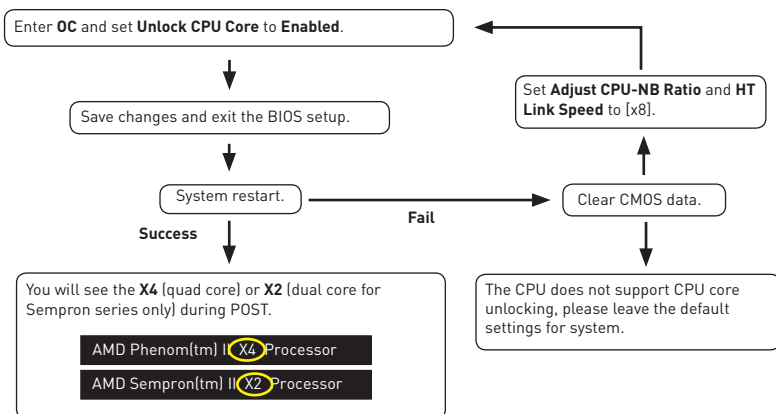

Important

- This CPU core unlocked behavior depends on the CPU ability/ characteristic, and it is not guaranteed.
- Depend on CPU's characteristic, once you get instable scenario, please restore the default settings for system.
- You can also check the core numbers in performance tab of Windows task manager.

▶ XXX Voltages control [Auto]

These options allows you to set the voltages related to components. If set to **Auto**, BIOS will set these voltages automatically or you can set it manually.

▶ Spread Spectrum [Disabled]

This function reduces the EMI (Electromagnetic Interference) generated by modulating clock generator pulses.

[Enabled] Enables the spread spectrum function to reduce the EMI (Electromagnetic Interference) problem.

[Disabled] Enhances the overlocking ability of CPU Base clock.

Important

- If you do not have any EMI problem, leave the setting at [Disabled] for optimal system stability and performance. But if you are plagued by EMI, select the value of Spread Spectrum for EMI reduction.
- The greater the Spread Spectrum value is, the greater the EMI is reduced, and the system will become less stable. For the most suitable Spread Spectrum value, please consult your local EMI regulation.
- Remember to disable Spread Spectrum if you are overlocking because even a slight jitter can introduce a temporary boost in clock speed which may just cause your overlocked processor to lock up.

▶ CPU Specifications

Press **Enter** to enter the sub-menu. This sub-menu displays the information of installed CPU. You can also access this information menu at any time by pressing **F4**. Read only.

▶ CPU Technology Support

Press **Enter** to enter the sub-menu. The sub-menu shows the key features of installed CPU. Read only.

▶ MEMORY-Z

Press **Enter** to enter the sub-menu. This sub-menu displays all the settings and timings of installed memory. You can also access this information menu at any time by pressing **F5**.

▶ DIMMx Memory SPD

Press <Enter> to enter the sub-menu. The sub-menu displays the information of installed memory. Read only.

▶ CPU Features

Press **Enter** to enter the sub-menu.

▶ AMD Cool' n' Quiet [Auto]

Enabled or disabled AMD Cool' n' Quiet function.

[Auto] Depends on AMD Design.

[Enable] Enables AMD Cool' n' Quiet function. The Cool' n' Quiet technology can effectively and dynamically lower CPU speed and power consumption.

[Disabled] Disables this function.

Important

*When adjusting CPU Ratio, the **Cool' n' Quiet** function will be disabled automatically. For CPU which supports the **Turbo Core Tech.**, please set **AMD Turbo Core Technology** and **AMD Cool' n' Quiet** as **Disabled** to retain the default CPU core speed.*

▶ C1E Support

Enables this item to reduce the CPU power consumption while idle. Not all processors support Enhanced Halt state (C1E).

▶ SVM Mode [Enabled]

Enables or disables CPU Virtualization.

[Enabled] Enables CPU Virtualization and allows a platform to run multiple operating systems in independent partitions. The system can function as multiple systems virtually.

[Disabled] Disables this function.

▶ IOMMU Mode

Enables/disables the IOMMU (I/O Memory Management Unit) for I/O Virtualization.

M-FLASH



Important

M-Flash function allows you to update BIOS from USB flash disk (FAT32/ NTFS format only).

▶ **Save BIOS to storage**

Saves the current BIOS file to the USB flash disk. The USB flash disk drive should be in FAT32 format.

▶ **Update BIOS**

Selects a BIOS file in the USB flash disk (NTFS/ FAT32 format) to update the BIOS.

▶ **Select one file to update BIOS**

Selects a BIOS file in the USB flash disk (NTFS/ FAT32 format)

OC PROFILE

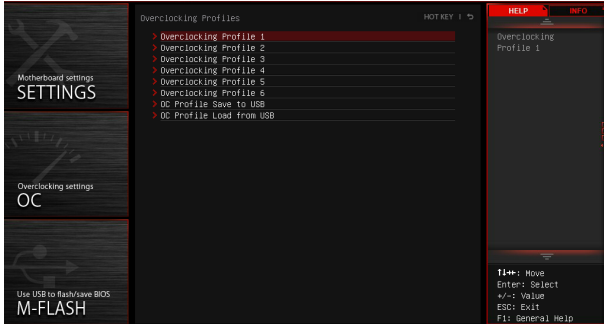

► Overclocking Profile 1/ 2/ 3/ 4/ 5/ 6

Overclocking Profile 1/ 2/ 3/ 4/ 5/ 6 management. Press **Enter** to enter the sub-menu.

► Set Name for Overclocking Profile 1/ 2/ 3/ 4/ 5/ 6

Name the current overclocking profile.

► Save Overclocking Profile 1/ 2/ 3/ 4/ 5/ 6

Save the current overclocking profile.

► Load Overclocking Profile 1/ 2/ 3/ 4/ 5/ 6

Load the current overclocking profile.

► Clear Overclocking Profile 1/ 2/ 3/ 4/ 5/ 6

Clear the current overclocking profile.

► OC Profile Save to USB

Save OC profile to the USB flash drive. The USB flash drive should be FAT/ FAT32 format only.

► OC Profile Load from USB

Load OC profile from the USB flash drive. The USB flash drive should be FAT/ FAT32 format only.

HARDWARE MONITOR

Temperature & Speed graphic display



► Temperature & Speed information

Shows the current CPU temperature, system temperature and fans' speeds.

► Temperature & Speed graphic display

The red graph shows the minimum and maximum temperatures that be set on the **Fan control field**. The yellow graph shows current CPU/ system temperature. The green shows current CPU/ System fan speed.

► Fan control field

Smart Fan Control automatically controls fan speed depending on the current CPU temperature and to keep it with a specific operating speed. When the current CPU temperature is over the maximum temperature, the CPU/ system fan will run at the maximum speed. When the current CPU temperature is under the minimum temperature, the CPU/ system fan will run at the minimum speed. In this field, you can set the CPU and system fans' speeds and target temperatures.

Important

The changing will achieve after you save the changes and reboot the system.

► Voltage display

Shows the current voltages of CPU, system and memory.

Software Description

Installing Windows® 7/ 8.1/ 10

1. Power on the computer.
2. Insert the Windows® 7/ 8.1/ 10 disc into your optical drive.
3. Press the **Restart** button on the computer case.
4. Press **F11** key during the computer POST (Power-On Self Test) to get into Boot Menu.
Note: It is suggested to plug in your USB Keyboard/ USB Mouse to the leftmost USB port when installing Windows® 7.
5. Select your optical drive from the Boot Menu.
6. Press any key when screen shows **Press any key to boot from CD or DVD...** message.
7. Follow the instructions on the screen to install Windows® 7/ 8.1/ 10.

Installing Drivers

1. Start up your computer in Windows® 7/ 8.1/ 10.
2. Insert MSI® Driver Disc into your optical drive.
3. The installer will automatically appear and it will find and list all necessary drivers.
4. Click **Install** button.
5. The software installation will then be in progress, after it has finished it will prompt you to restart.
6. Click **OK** button to finish.
7. Restart your computer.

Installing Utilities

Before you install utilities, you must complete drivers installation.

1. Insert MSI® Driver Disc into your optical drive.
2. The installer will automatically appear.
3. Click **Utilities** tab.
4. Select the utilities you want to install.
5. Click **Install** button.
6. The utilities installation will then be in progress, after it has finished it will prompt you to restart.
7. Click **OK** button to finish.
8. Restart your computer.

COMMAND CENTER

COMMAND CENTER is a user-friendly software and exclusively developed by MSI, helping users to adjust system settings and monitor status under OS. With the help of COMMAND CENTER, making it possible to achieve easier and efficient monitoring process and adjustments than that under BIOS. In addition, the COMMAND CENTER can be a server for mobile remote control application.

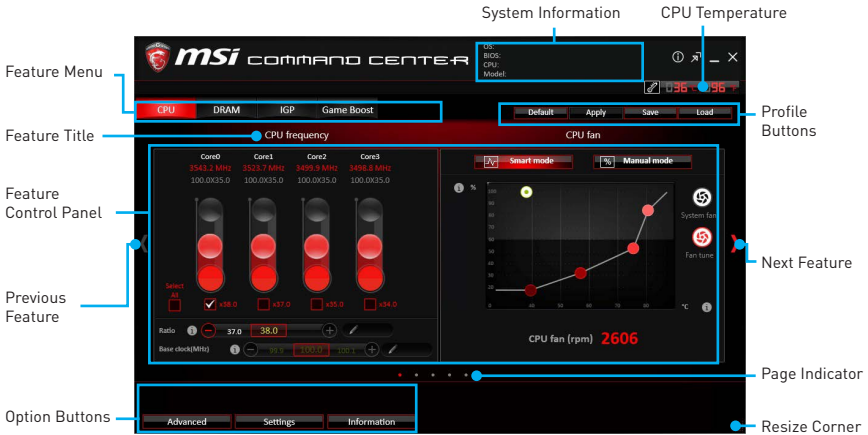

Profile Buttons



- **Default** - load the default values for the current feature.
- **Apply** - apply your changes.
- **Save** - store values in the file with individual file extension.
- **Load** - load the values from the file.

Important

Every time you shut down the system, the configured setting will be restored to the factory default. If you want to use the saved settings, you have to load it every time by clicking the **Load** and **Apply** buttons.

CPU Frequency

CPU Frequency control panel allows you to change CPU Ratio and Base clock. You can see the current frequency of each CPU core on the top of the panel.

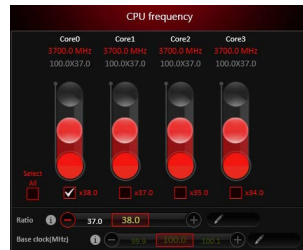

CPU Fan

CPU Fan control panel provides **Smart mode** and **Manual Mode**. You can switch the control mode by clicking the **Smart Mode** and **Manual Mode** buttons on the top of the CPU Fan control panel.

- **Manual Mode** - allows you to manually control the CPU fan speed by percentage.
- **Smart Mode** - a linear fan speed control feature. The control panel contains 4 dots allows you to drag and adjust the Smart Speed slopes. The fan speed will be changed along these lines with CPU temperature. The white dot will create strip chart in real time.
- **System Fan Button** - to open the system fan control panel in new window.
- **Fan Tune Button** - to automatically optimize the smart fan setting.

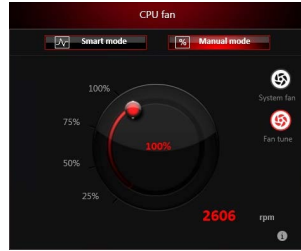

Manual Mode

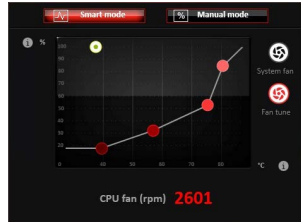

Smart Mode

CPU Voltage

CPU Voltage control panel allows you to control the CPU voltage.



DRAM Frequency & DRAM Voltage

- **DRAM Frequency** - Shows the DRAM clock, ratio and frequency.
- **DRAM Voltage** - Allows you to adjust the DRAM voltage. The risky values are displayed in red.



IGP Frequency & GT Voltage

- **IGP Frequency** - Allows you to adjust the IGP ratio, and shows the IGP clock, ratio and frequency.
- **GT Voltage** - Allows you to adjust the GT voltage. The risky values are displayed in red.

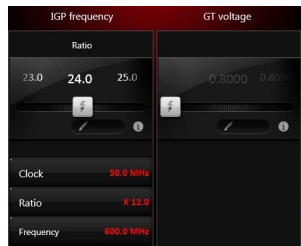

Option Buttons - Advanced

When click the **Advanced** button, The **Voltage**, **Fan** and **DRAM** icons will appear.



- **Voltage** - allows you to adjust advanced voltage values of CPU and chipset.
- **Fan** - allows you to control the system fans speed.
- **DRAM** - shows the current Advanced DRAM parameters, and allows you to change the settings by selecting values from the drop-down menu on the right hand side.
- **Sensor** - allows you to monitor your motherboard temperature and fan speed with the virtual thermal image. You can drag and drop the fan icons to new locations. When you press the **Cooling** button, all fans will run at full speed.

Option Buttons - Setting

When click the **Setting** button, The **Record**, **Warning** and **Mobile Control** icons will appear.



- **Record** - allows you to monitor the status of voltage, fan speed and temperature in real time.
 - To filter record charts, select the check box next to the items.
 - When click the **Play** button, the chart pane will start to show the recording chart. If you want to check the value of a specific spot on chart, please move the orange vertical line to the spot.
 - History Record stores the data and names with date and time.
 - To make a history record: Select items and click the **Record** button. When finished, click the **Record** button again. The data will be stored in the drop-down menu.
 - To load a record, click the drop-down menu and select one from the list.
 - To delete a record, select the record that you want to delete, and click the **Trash Can** icon.
- **Warning** - contains fields of voltage, fan speed and temperature for you to set the threshold values. When system detects the status over your settings, a warning message will pop-up.

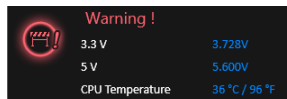

- **Mobile Control** - is only available for the motherboard with the built-in WiFi module. It allows you to enable/disable the COMMAND CENTER Remote Server. Please refer to the instruction on the Mobile Control control panel.
- **To start remote control: (optional)**
 1. Download and install **MSI® COMMAND CENTER APP** to your mobile device.
 2. Enable **COMMAND CENTER Remote Server** on the **Mobile Control** panel.
 3. Enable **SoftAP Management**.
 4. Enter **SSID** and **Password**, and then click the **Apply** button.
 5. Activate Wi-Fi® on your mobile device and connect to SoftAP with the SSID.
 6. Run **MSI® COMMAND CENTER APP** on your mobile device.
 7. Find the IP address on the **SoftAP Management Setting** area, and enter the IP address on your **MSI® COMMAND CENTER APP** to link your system.
 8. Press **Refresh** on the **MSI® COMMAND CENTER APP** to verify that monitoring and OC functions are working properly.

Option Buttons - Information

When click the **Information** button, The **Motherboard, CPU, Memory** and **HW monitor** icons will appear.



You can click the icons to open the related information.

Gadget Mode

COMMAND CENTER provides a gadget mode to monitor the system status. You can switch between gadget mode and full mode by clicking the arrow icon  on the top left.

- **To arrange gadgets:**
 1. Click the Spanner icon  on the Gadget mode, a configuration panel will slide out.
 2. Select the check box next to the items.
 3. Click the **Close** button.

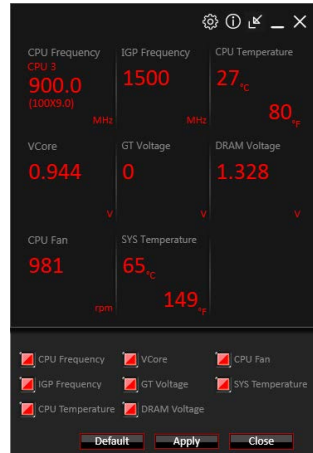

LIVE UPDATE 6

LIVE UPDATE 6 is an application for the MSI® system to scan and download the latest drivers, BIOS and utilities. With LIVE UPDATE 6, you don't need to search the drivers on websites, and don't need to know the models of motherboard and graphics cards. LIVE UPDATE 6 will download the appropriate drivers automatically.

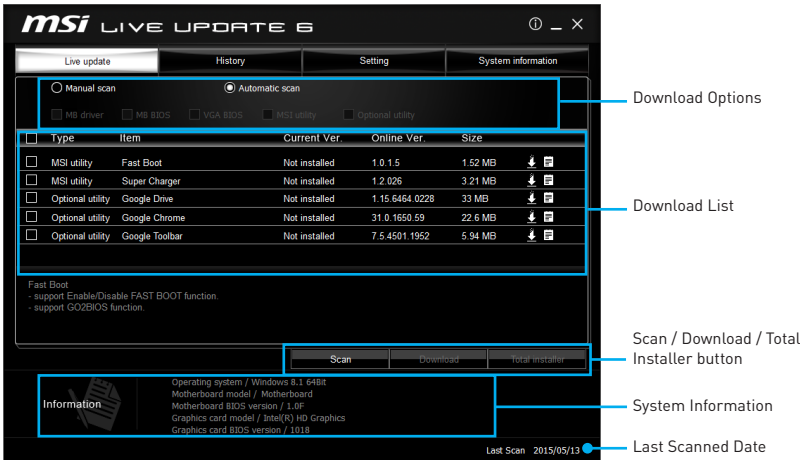

There are **Live Update**, **History**, **Setting** and **System Information** tabs at the top. You can click the tab to switch the control panel.

- **Live Update** - When you launch LIVE UPDATE 6, you will see the Live update tab at first. This tab allows you to select files to download. You can also read the relevant information by clicking the information icon  on the right of the item listed.
- **History** - shows the downloading history.
- **Setting** - allows you to specify the frequency that LIVE UPDATE 6 remind you to update.
- **System Information** - displays the information of the system.

Updating The System

This section describes how to update your system with LIVE UPDATE 6. Please follow the steps below:

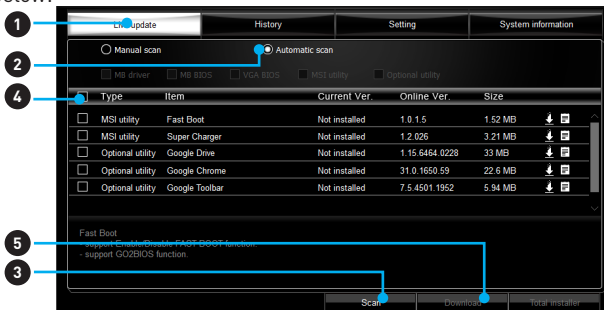

1. Select the **Live Update** tab.

- Choose **Automatic scan**, system will automatically scan all the items and search for the latest update files. Or you can choose **Manual scan** and select the items you wish to scan.
- Click the **Scan** button at the bottom. It may take several moments to complete the process.
- When the download list appears, please select the items you intend to update.
- Click **Download** button at the bottom.
- When **Save Path** prompt, you can specify a download directory.

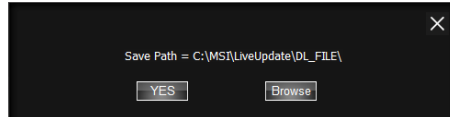

- When downloading you will see the screen below. It may take several moments to complete the process.

Type	Item	Latest Ver.	Size	Download
MSI utility	Fast Boot	1.0.1.5	1.52 MB	<div style="width: 46%;"></div> 46 %
MSI utility	Super Charger	1.2.026	3.21 MB	

- To install the applications, simply unpack the packages and install.

Total Installer

Total Installer is a convenient feature to simplify frequent installing procedure. To use Total Installer:

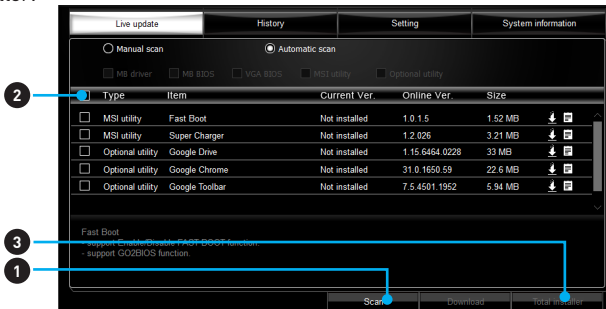

- Scan** updates in **Live Update** tab.
- Check the **Select All** check-box you intend to update.
- Click the **Total Installer** button. LIVE UPDATE 6 will automatically install them.
- When prompted, click **OK** to complete the Total Installer procedure
- Reboot your system.

GAMING APP

GAMING APP is an application designed to quickly control your system for improving gaming performance.

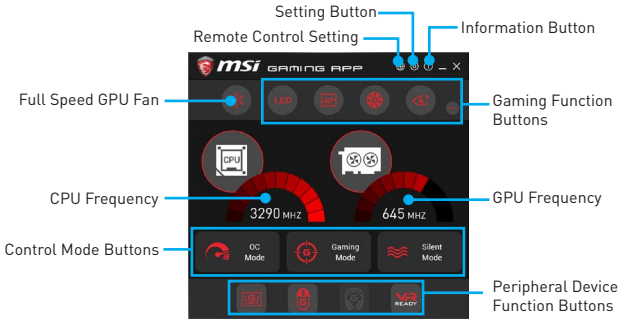

- **Setting Button** - allows you to run GAMING APP when Windows starts.
 - **Information Button** - shows the information of this application.
 - **CPU Frequency** - shows the current CPU frequency.
 - **Control Mode Buttons**
 - **OC Mode** - enables Game Boost function to automatically overclock the CPU.
 - **Gaming Mode** - automatically optimize the CPU ratio and the GPU clock.
 - **Silent Mode** - reverts the CPU ratio and GPU clock to the default values.
 - **Gaming Function Buttons** - allows you to use **LED Effect**, **OSD**, **Eye Rest** and **Dragon Eye** functions. (Dragon Eye button only appear when the graphics card is installed)
 - **Peripheral Device Function Buttons** - allows you to set the **Gaming Hotkey**, **Mouse Master** and **VR Ready** functions.
 - **Remote Control Setting** - is only available for the motherboard with the built-in WiFi module or with an external WiFi home router. It allows you to set up a set of **Name** and **Password** to link the android device the motherboard. Please refer to the following instructions to complete the remote control setting.
1. Download and install the **MSI® GAMING APP** APP to your android device.
 2. Set up a set of **Name** and the **Password** on the **Remote Control Setting** panel, and then click the **Apply** button.
 3. Activate Wi-Fi® on your android device and connect it to the wireless network of the motherboard.
 4. Run **MSI® GAMING APP** APP on your android device.
 5. Press the **Remote Control Setting** icon on the **MSI® GAMING APP** APP to find the paired device **Name** you set on the **Remote Control Setting** panel.
 6. Enter the **Password** you set on the **Remote Control Setting** panel.0
 7. Finally, you can use the **MSI® GAMING APP** APP to control the aspect of your motherboard with the android device.

LED Effect

LED Effect allows you to control LED lights on your motherboard.

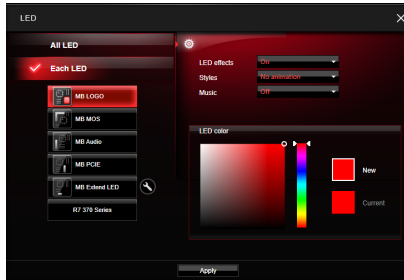

- **All LED** - controls all LEDs on your motherboard.
- **Each LED** - separately controls each segment of LEDs on your motherboard.
 - **MB Extend LED** - controls the extended RGB LED strip. Please follows the steps to calibrate the RGB LED color.
 1. Click on the  icon and a calibration pop-up window will show.
 2. Click on the **arrow** icon to go to next step.
 3. Click on the **RED**, **GREEN** and **BLUE** buttons separately to calibrate the LED red, green and blue colors.
 4. Click on the **Finish** to complete the RGB LED color calibration.
- **LED effects** - switches LEDs on or off.
- **Styles** - select the LED style from the drop-down list.
- **Music** - flashes the LED light with music's beat. It will only function with the music output from analog audio ports.
- **LED color** - allows you change the LED color.
- **Apply Button** - applies **LED Effect** settings to LEDs.

Important

The **Stack**, **Marquee**, **Meteor**, **Rainbow** and **Music** light effects can only support to sync all LEDs effect. If you want to control each segment of LEDs, please set the other LED effects.

OSD Setting Panel

Use the OSD setting panel to specify information within on-screen display (OSD).

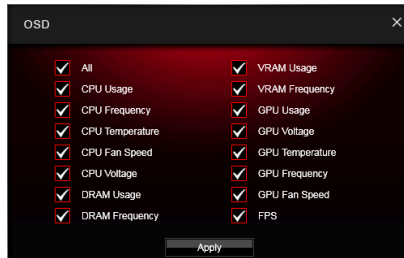

- **Apply Button** - allows you to accept selections.

Eye Rest

Eye Rest allows you to optimize the display on your monitor.

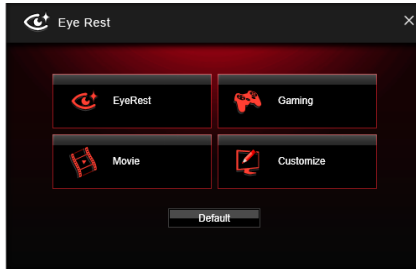

- **EyeRest** - reduces blue-light of your LED backlit screen, in order to protect your eyes.
- **Gaming** - automatically increase contrast ratio of your screen.
- **Movie** - automatically increase dynamic contrast ratio of your screen.
- **Customize** - allows you to adjust gamma, contrast and color balance for your screen.
- **Default** - loads the default settings.

VR Ready

VR Ready can automatically detects VR devices connected to the system. When enabled, it can provide the right advice to make sure your system is VR Ready.

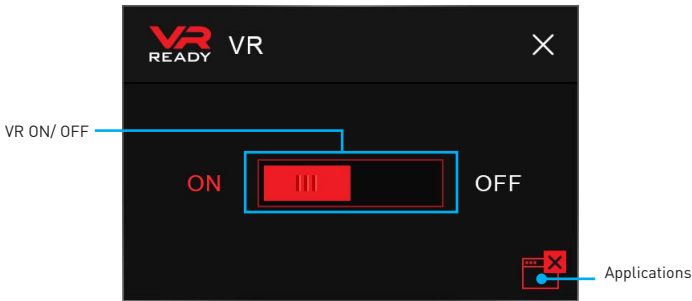

- **VR ON/ OFF** -enables or disables VR device support.
- **Applications** - appears when you turn on the VR support. It allows you to close some applications to optimize the system for better VR experience.

Gaming Hotkey

Gaming Hotkey provides instant control of the system through user defined hotkeys.

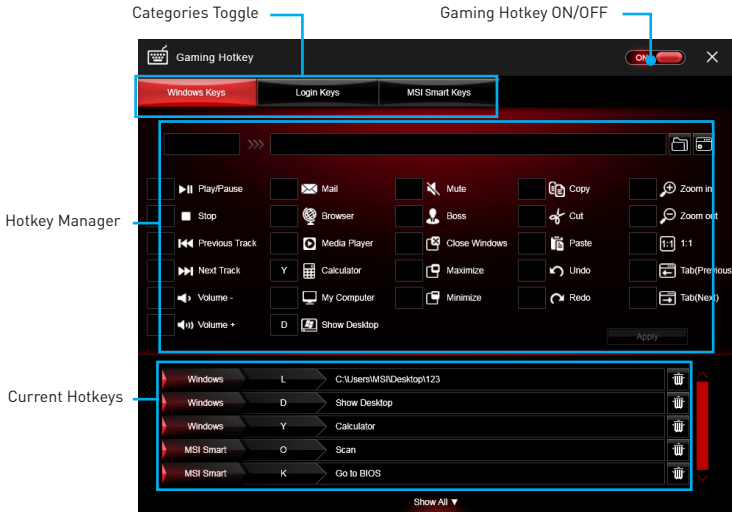

- **Gaming Hotkey ON/OFF** - allows you to turn ON/OFF the Gaming Hotkey function.
- **Categories Toggle** - allows you to toggle over the Hotkey categories .
 - **Windows Keys** - allows you to define hotkeys to replace Windows default keyboard shortcuts.
 - **Login Keys** - provides hotkey login function.
 - **MSI Smart Keys** - allows you to define hotkeys for MSI Smart Keys.
- **Hotkey Manager** - allows you to create, edit and delete hotkeys.
- **Current Hotkeys** - shows all existing hotkeys.

Important

- The **Caps Lock**, **Num Lock**, **Scroll Lock**, **Window Home**, **Application** and **BackSpace** keys can not be used as hot-keys.
- Some key combinations are reserved for use by Microsoft Windows and can not be assigned as a hotkey.

Mouse Master

Mouse Master provides mouse macro function. You can also use it to change DPI of your mouse.



- **Delay Time** - allows you to input delay time and click the **Add** button to insert a delay in the macro.
- **Macro Hot Key** - allows you to assign a hotkey from A to Z to activate the macro.
- **Mouse Action** - assigns mouse actions to the macro.
 - **New** - captures the mouse coordinate and add to the macro.
 - **Left** - add a left-click to the macro.
 - **Middle** - add a middle-click to the macro.
 - **Right** - add a right-click to the macro.
- **Action List** - shows the actions of the current macro.
- **Edit Buttons** - there 3 buttons for editing the macro.
 - **Run** - activates the macro.
 - **Delete** - removes the selected action from the macro.
 - **Clear** - removes all actions from the macro.
- **Load Button** - allows you to load a macro.
- **Save Button** - allows you to save the macro to a file.
- **DPI Setting** - allows you select the mouse DPI from the drop-down menu.
- **Default Button** - reverts to the default DPI setting.
- **DPI Hot Key** - allows you to assign a hotkey from A to Z to activate the DPI setting. Please note that you must hold the hotkey to keep the DPI setting. When you release the hotkey, the DPI setting will be reverted to default.
- **Test Area** - allows you to test the mouse movement.
- **Clear Button** - clears the test area.

USB SPEED UP

Enabling USB SPEED UP can speed up the data transfer rates of the USB storage devices.

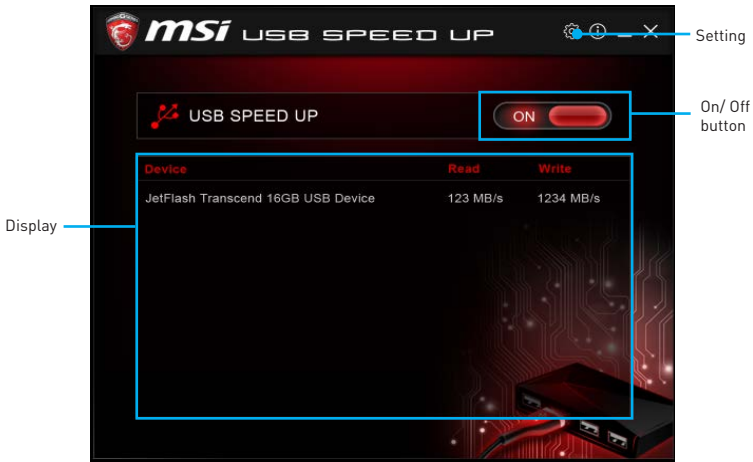

- **Setting** - enables or disables **Run USB SPEED UP when windows starts.**



- **On/ Off button** - switches the USB SPEED UP on or off.
- **Display** - displays the information and current transfer rates of USB storage devices.

Important

The improved transfer rate will vary with the USB storage devices.

GAMING LAN MANAGER

GAMING LAN MANAGER is an utility for traffic shaping for the Windows 7/ 8.1/ 10. It can keep your internet fast during heavy upload/ download and improve your ping for online games. If your motherboard has a Wi-Fi module, GAMING LAN MANAGER provides virtual access point function for traffic shaping for your mobile devices.

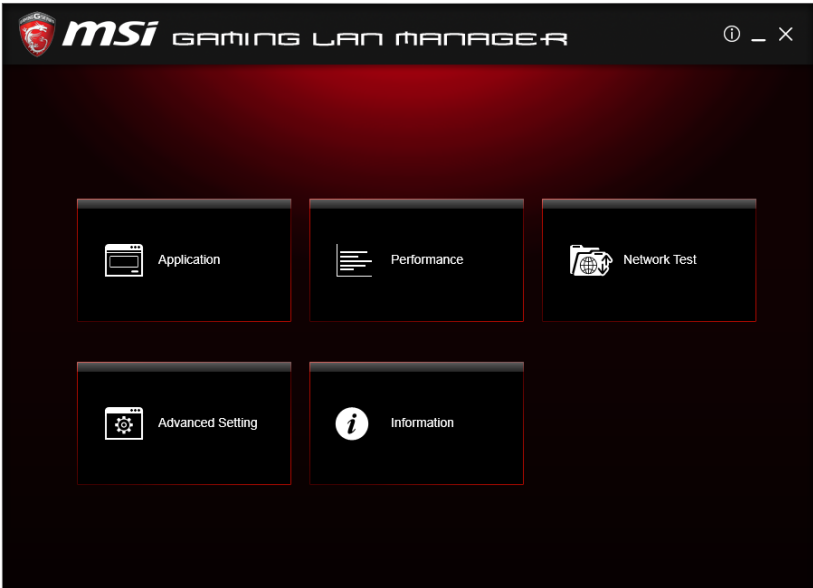

- **Applications** - displays currently using network bandwidth applications. You can prioritize Games, Medias or File sharing programs as high as possible.
- **Performance** - shows top 5 applications by total traffic, allows you to monitor network bandwidth usage.
- **Network Test** - allows you to setup bandwidth control.
- **Advanced Setting** - allows you to expand RWIN to accelerate download speed. You can also block IP address and setup virtual access point.
- **Information** - shows version information.

Configuring Bandwidth

This section describes how to configure Internet Provider Speed. You can configure default internet upload and download bandwidth from the Network Test tab on the GAMING LAN MANAGER window.

Important

*Before using the GAMING LAN MANAGER for the first time, you should use the **Test Network Speed** button which runs a speed test of your current total Internet bandwidth delivered through your Internet service provider.*

Speed Testing

The speed testing is used to optimize bandwidth usage. To test the Upload and Download speed, please follow the steps below:



1. Click the **Network Test** block in GAMING LAN MANAGER.

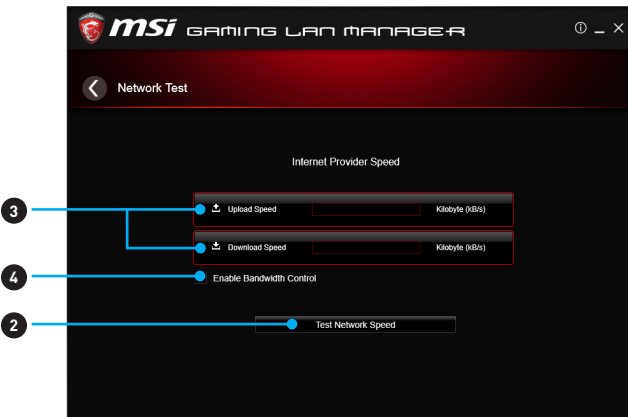

2. Click **Test Network Speed** button. The test takes several minutes to test your network speed.
3. Enter the testing results into **Upload Speed** and **Download Speed** fields.
4. Check the **Enable Bandwidth Control** to allow the GAMING LAN MANAGER to manage the bandwidth.

Nahimic 2

Nahimic 2 is designed to offer the best audio experience it contains 6 audio effects, 3 microphone effects, HD Audio Recorder2 and Sound Tracker.

Installation and Update

Nahimic 2 is included in the audio driver. If you need to install it or update it, please use the **Driver Disc** with your motherboard or download the driver from MSI's official website.

Audio Tab

From this tab, you can access all of Nahimic 2's audio effects, audio profiles and settings.



- **Display & Volume** - displays the type of audio rendering device currently being used as output, as well as its current volume.
 - **Mute** - mutes the current audio output device.
 - **Device properties** - allows you to change the format, sample rate, bit rate and the channel gain of the current device (if these options are available for the current device). Clicks on this button and a device properties panel will show.
- **Profiles** - allows you to adjust the 6 audio effects to your current listening experience.
 - **Gaming** - allows you to choose an audio profile to fit your gaming experience.
 - **Multimedia** - allows you to choose an audio profile to fit your everyday experience.
- **Audio Effects** - allows you to separately control any of the 6 audio effects.
 - **Bass Boost** - increases the energy in low frequencies up to +12 dB.
 - **Virtual Surround**
 - **Gaming and Movies** - virtualizes the multichannel audio stream and downmixes it in order to retrieve a multichannel listening experience over your stereo headphones or speakers.
 - **Music** - expands the stereo for a wider sound stage.
 - **Reverb** - increases the feeling of space by applying different types of reverbs corresponding to different room sizes.
 - **Treble Enhancer** - Increases the energy in high frequencies up to +12 dB.

- **Smart Loudness** - maintains a constant volume for all elements of the audio experience to making them all sound softer, balanced or louder.
- **Voice Clarity** - boosts the speech in movies, video games and incoming communication from +0 through +12 dB (0 to 100%).
- **Reset Button** - restores the current profile to its default values.
- **On/Off Button** - allows you to turn on and off all Nahimic 2's effects in one click.
- **EQ Profile Page** - by clicking the arrow button, you can also access a second page that contains the x10 bands EQ and EQ profiles.



- **EQ Profiles** - allows you to choose between 6 EQ profiles to fit your audio experience
- **Custom EQ Profile** - you can change the x10 bands of the Custom EQ profile so as to make it fit your current needs.
- **x10 bands EQ** - x10 bands EQ, from 32Hz to 16KHz.

Microphone Tab

From this tab, you can access all of Nahimic 2's microphone effects and settings.

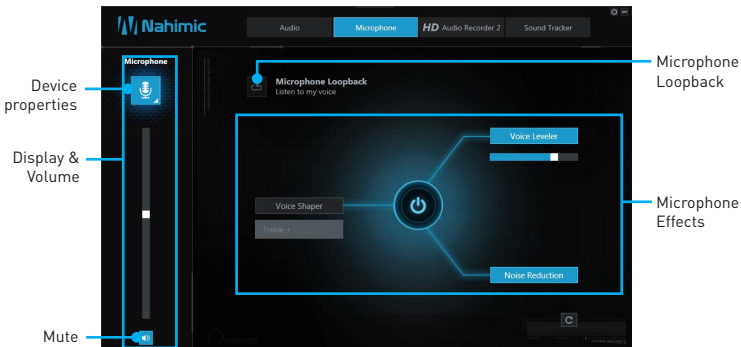

- **Display & Volume** - displays the type of audio recording device currently being used as input, as well as its current volume.
 - **Mute** - mutes the current device.

- **Device properties** - allows you to boost the volume and modify the left/ right balance of microphone. Clicks on this button and a device properties panel will show.
- **Microphone Loopback** - turns the microphone loopback On/Off. In order to avoid any feedback (Larsen effect).
- **Microphone Effects** - allows you to separately control any of the 3 microphone effects.
 - **Voice Shaper** - applies a filter to the voice.
 - **Voice Leveler** - levels the volume of your voice in order to avoid any saturation and maintains a constant and clear communication. Voice Leveler can be adjusted with a 0 to 100% slider.
 - **Noise Reduction** - removes the remaining sound that the Noise Gate has left on top of your words and sentences.

HD Audio Recorder 2

From this tab, you can access the audio launchpad and HD Audio Recorder 2 settings.

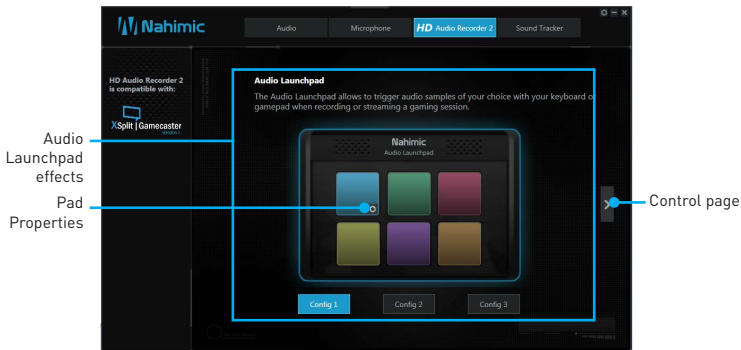

- **Audio Launchpad effects** - allows streamers to use prerecorded sounds during a livestream. These sounds can also be heard by viewers. This tool will allow you to create your true audio identity. That way, your livestreams will be more personal and animated. The Audio Launchpad is one of the fresh new features of Nahimic 2. As it's a feature designed for broadcasters, we included it in the HD Audio Recorder 2 page.
 - **Pad Properties** - every pad can be customized by clicking the properties button that will appear in its bottom right when hovering over it with your mouse. On the Pad Properties panel you can choose:
 - The sound assigned to each pad.
 - The keyboard hotkey assigned to each pad.
 - The color assigned to each pad.
 - **Config 1, 2 & 3** - allows you to prepare 3 completely different configurations so as to adapt the Launchpad to the content you are streaming. Each configuration has 6 customizable pads. The 3 configurations are independent, meaning Config 1 cannot be used at the same time than Config 3.

- **Control Page** - by clicking the arrow button, you can access the control page.

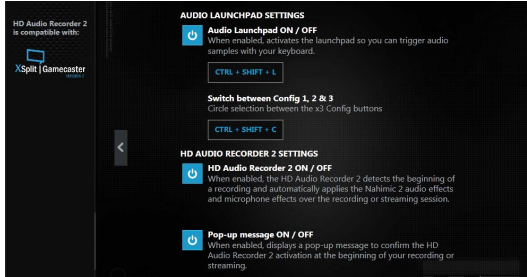

- **Audio Launchpad ON/OFF** - switches the Audio Launchpad on or off.
- **HD Audio Recorder 2** - The HD Audio Recorder 2 is, by default, automatically launched when a XSplit Gamecaster 2 recording session is detected. The launch of the HD Audio Recorder 2 enables HD audio processing over an XSplit Gamecaster 2 recording without any need for adjustments. The HD Audio Recorder supports XSplit Gamecaster 2.
- **Pop-up message ON/OFF** - switches the pop-up message on or off.

Sound Tracker

The Sound Tracker is an FPS oriented feature that provides a visual indication localizing the source of the strongest sound while in a game. The Sound Tracker captions the 5.1 and 7.1 sound streams processed by your audio system, and is displayed in all applications and games using DirectX 9, 9c, 10 and 11. Please remember Sound Tracker is only available if you are using an audio device that supports Nahimic 2 effects.

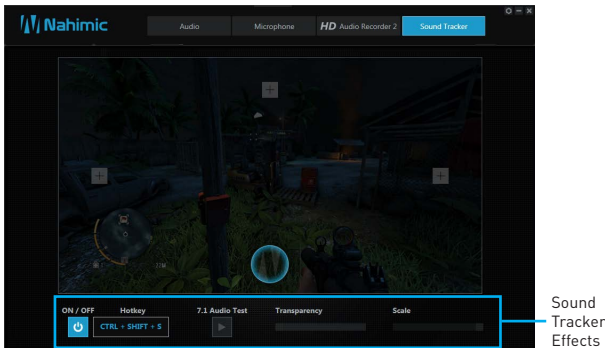

- **ON / OFF button and hotkey** - switches the Sound Tracker on or off.
- **Hotkey** - use the CTRL + SHIFT + S to turn ON / OFF the Sound Tracker.
- **7.1 Audio Test** - launch a 7.1 audio sample allowing you to preview how the radar will react in your game.
- **Transparency** - allows you to adjust the transparency of the Sound Tracker, making it look more or less discrete.
- **Scale** - allows you to adjust the scale of the Sound Tracker, making it look bigger or smaller.

SteelSeries Engine 3

SteelSeries Engine 3 is a unified platform built to support all of SteelSeries products. It can deploy your saved device settings automatically when switching between your favorite games or applications.

After installation the SteelSeries Engine background processes will start and the interface will open automatically.

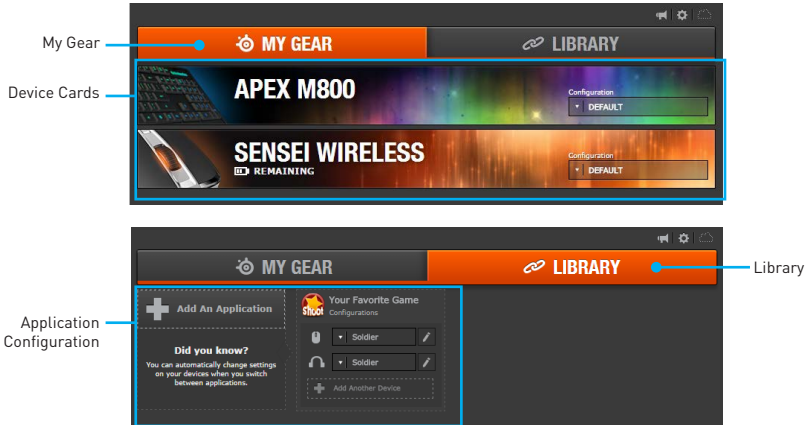

- **My Gear** - all of your SteelSeries devices in one place.
 - **Device Cards** - all of your SteelSeries devices are easily accessible from the My Gear tab, regardless of type, connection status, or which applications they are assigned to.
- **Library** - quickly set up your configurations to autolaunch with an application.
 - **Application Configuration** - you can choose to have configurations deploy automatically whenever you use a specific game or application. Add any number of applications to your library and SteelSeries Engine 3 will seamlessly change the configurations of your devices as you switch between them.

Configuration Windows

Configuration Windows are unique to their devices and each of them includes a collapsible **Configuration List Panel** of all the configurations for that device. You can create a new configuration by selecting the **New** button at the bottom of the Configuration List Panel.

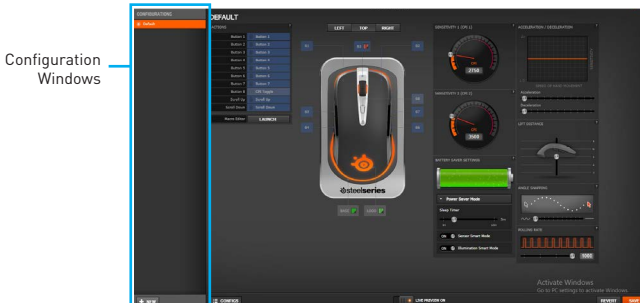

Configuring Your Devices

You can custom configurations for SteelSeries devices in their Configuration Windows. The top left displays the name of the configuration you are viewing, the body features widgets for customizing various functions of the device, and at the bottom are Save/ Revert buttons, a Live Preview toggle, and a button to open/close the collapsible Configuration List Panel.



- **Widgets** - allow you to customize a certain aspect of your device.
- **Widgets Toggle** - allows you to toggle Widgets .
- **Configuration Windows Toggle** - allows you to toggle the Configuration Windows.
- **Live Preview** - gives you the full experience of your configuration's look, feel, and sound while you are editing it.
- **Revert/ Save Button** - configuration changes are not written to the database until you select **Save**. This gives you freedom to experiment, knowing that you can select **Revert** to undo changes.

Tool Tip

When you click the question mark next to a feature name on the panel, a tooltip will show, describing the particular function of that item.

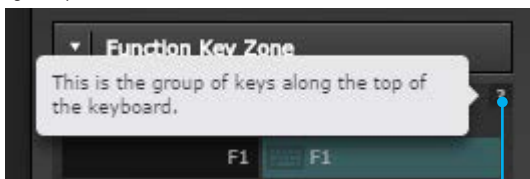

Question Mark

DRAGON EYE

DRAGON EYE is an application that allows you to watch a game guide, tutorial, live match or tournament stream while playing a game. In the game, you can use hotkeys to control / adjust the window of video.

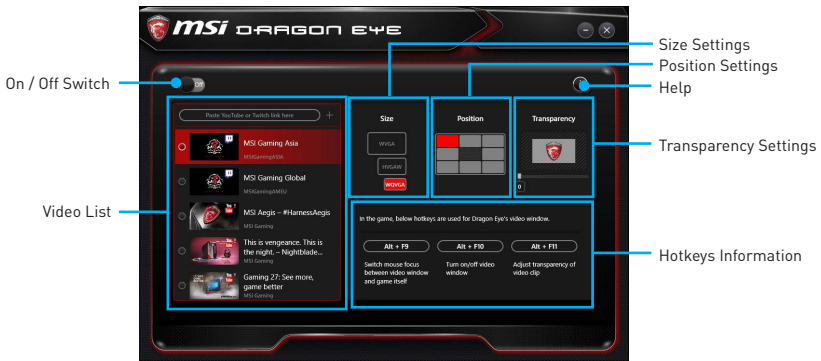

- **On / Off Switch** - enables or disables Dragon Eye during your gaming sessions. Switch it on before you launch the game in order to watch video while playing.
- **Video List** - allows you to select the video you want to watch, and also add videos or channels to the list. You simply paste the URL of your video or stream into the input bar and hit the +. Then your video or stream will be in the list and you can select it to view it with Dragon Eye.
- **Size Settings** - allows you to select the size of the Dragon Eye video content displayed on-screen when you're playing a game. There are three options available:
 - WQVGA (Small – 400 × 240)
 - HVGAW (Medium – 640 × 360)
 - WVGA (Large – 768 × 480)
- **Position Settings** - allows you to select where the Dragon Eye video needs to be displayed on screen. This way you can control where you want your video in-game, so you can place it on a place where no important game information is.
- **Help** - If you want to watch the video tutorial for Dragon Eye or want to see if your game is supported, press this button and the help window will be shown.
- **Transparency Settings** - allows you to set the transparency of your Dragon Eye video.
 - 0 = opaque | 100 = transparent.
- **Hotkeys Information** - In this information screen you can find the hotkeys for Dragon Eye. There are three hotkeys:
 - **Alt+F9** - switches mouse focus between video window and game itself. (Direct interface to adjust progress bar, volume and other settings of video during the game)
 - **Alt+F10** - turns on/off video window .
 - **Alt+F11** - adjusts transparency of video clip.

NOTE: To customize hotkey, simply select the hotkey icon and then press the keys combination you want to use as a hotkey.

RAID Configuration

Below are the different types of a RAID.

- RAID 0** breaks the data into blocks which are written to separate hard drives. Spreading the hard drive I/O load across independent channels greatly improves I/O performance.
- RAID 1** provides data redundancy by mirroring data between the hard drives and provides enhanced read performance.
- RAID 5** provides data striping at the byte level and also stripe error correction information. This results in excellent performance and good fault tolerance.
- RAID 10** uses four hard drives to create a combination of RAID 0 and 1 by forming a RAID 0 array from two RAID 1 arrays.

RAID level comparison

	RAID 0	RAID 1	RAID 5	RAID 10
Minimum # drives	2	2	3	4
Data protection	None	Excellent	Excellent	Excellent
Read performance	Excellent	OK	Good	OK
Write performance	Excellent	Good	OK	Good
Capacity utilization	100%	50%	67%~(1-1/n)	50%

Using RAID Option ROM

First, you need to set the **SATA mode** to **RAID** in BIOS to create and delete RAID volumes. To enter the RAID Option ROM, reboot and press **Ctrl + F** keys to enter the RAID Option ROM during the POST, the following window will appear.

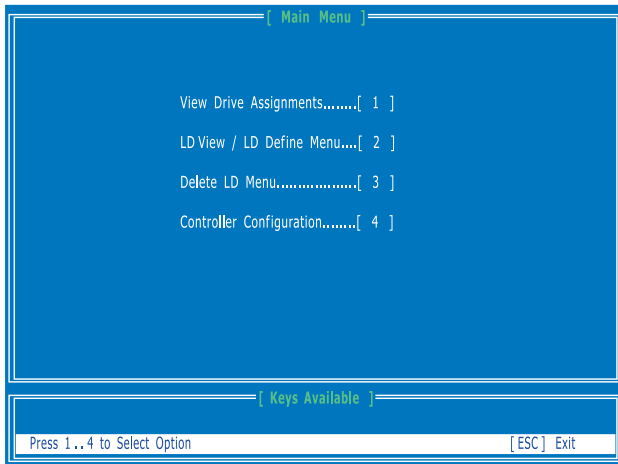

View Drives Assignments

This window displays the model number, capacities and assignment of the drives physically attached to the SATA host adapter.

[View Drives Assignments]				
Port : ID	Drive Model	Capabilities	Capacity (GB)	Assignment
01 : 00	ST32000641AS	SATA 6G	2000,39	
	Extent 1		2000,39	<Single Disk>
02 : 00	ST32000641AS	SATA 6G	2000,39	
	Extent 1		2000,39	<Single Disk>

[Keys Available]				
[↑] Up	[↓] Down	[PaUp / PaDn] Switch Page	[Ctrl + H] Full Erase	
[ESC] Exit				

LD View / LD Define Menu (Creating RAID)

The selection of the RAID configuration should be based upon factors including performance, data security, and the number of drives available. It is best to carefully consider the long-term role of the system and plan the data storage strategy. RAID sets can be created either automatically, or to allow the greatest flexibility, manually.

1. Press **2** on the Main Menu screen to enter the LD View Menu.

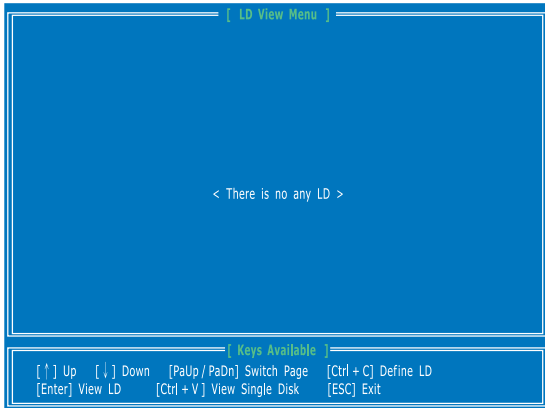

2. And then press **Ctrl + C** keys to enter the LD Define Menu. Use the space key to choose a RAID mode (RAID 0/ 1/ 10/ 5) and use the arrow key to move to the **Drives Assignments** window.

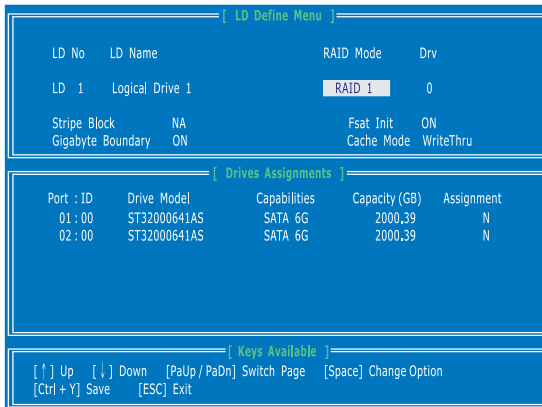

- Stripe Block Size, the default 64KB is best for most applications. RAID 0 or 10 only.
- Gigabyte Boundary, allows use of slightly smaller replacement drives.

- On the Drives Assignments window, use the arrow key to choose the hard drives which you want to make part of the LD, use the space key to change the assignment to **Y**. Then press **Ctrl + Y** to save the configuration.

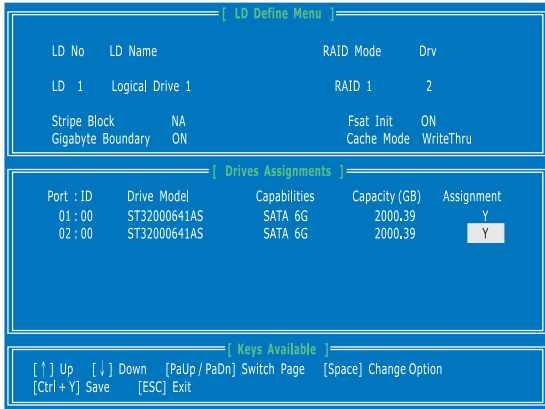

- A message will show, press **Ctrl + Y** to input a LD name as your desire or press any key to save default LD name.

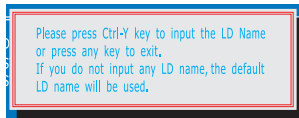

- Another message will show, press **Ctrl + Y** if you are sure to erase the MBR data of the disk. Or press any key to ignore this option.

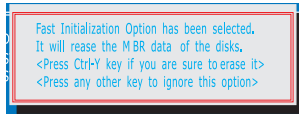

- The message will show up on the bottom, press any key to use maximum capacity or press **Ctrl + Y** to modify array capacity manually.

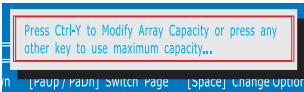

Important

- The default capacity is the full capacity of the selected hard drives.
- If you allocate the first LD capacity manually, you can create second LD with remaining capacity of the selected hard drives.

7. The LD creation is done, the screen shows the LD information as below. Press ESC key to the main screen.

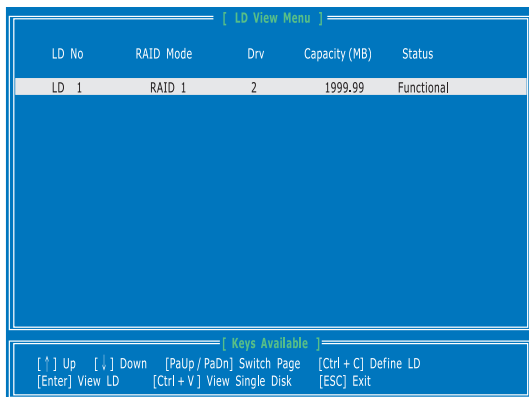

The screenshot shows the 'LD View Menu' screen. At the top, it says '[LD View Menu]'. Below that is a table with the following data:

LD No	RAID Mode	Drv	Capacity (MB)	Status
LD 1	RAID 1	2	1999.99	Functional

Below the table is a 'Keys Available' section with the following options:

Keys Available		
[↑] Up	[↓] Down	[PaUp/PaDn] Switch Page
[Enter] View LD	[Ctrl+V] View Single Disk	[Ctrl+C] Define LD
		[ESC] Exit

8. Press **ESC** key to exit the utility, a message **System is going to REBOOT! Are You Sure?** will display, answer **Y** to exit it and the system will reboot.

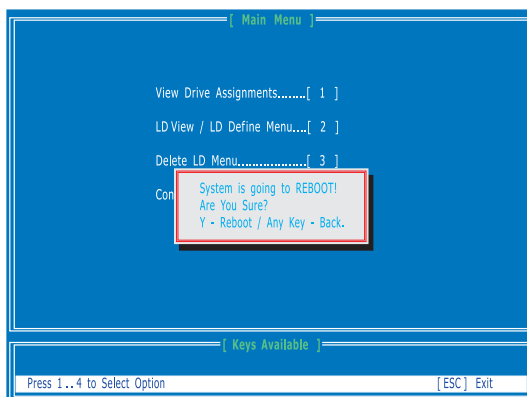

The screenshot shows the 'Main Menu' screen. At the top, it says '[Main Menu]'. Below that are several menu options:

- View Drive Assignments.....[1]
- LD View / LD Define Menu....[2]
- Delete LD Menu.....[3]
- Con [4]

A red-bordered dialog box is overlaid on the screen with the following text:

System is going to REBOOT!
Are You Sure?
Y - Reboot / Any Key - Back.

At the bottom, there is a 'Keys Available' section with the following options:

Keys Available	
Press 1..4 to Select Option	[ESC] Exit

Delete LD Menu (Deleting RAID)

1. Press **3** on the main to enter the Delete LD Menu.
2. Choose a **LD No.** you want to delete and press **Del** or **Alt + D** delete the RAID set.

[Delete LD Menu]				
LD No	RAID Mode	Drv	Capacity (MB)	Status
LD 1	RAID 1	2	1999,99	Functional

[Keys Available]				
[↑] Up	[↓] Down	[PaUp / PaDn] Switch Page	[Del / Alt + D] Delete LD	

3. On the next screen, a message will display to inform you, press **Ctrl + Y** to delete the RAID set or other key to abort it. Press **Ctrl + Y** to complete the deletion.

[View LD Definition Menu]				
LD No	LD Name	RAID Mode	Drv	Capacity (GB)
LD 1	Logical Drive 1	RAID 1	0	1999,99
Stripe Block	NA	Cache Mode	WriteThru	

[Drives Assignments]				
Port : ID	Drive Model	Capabilities	Capacity (GB)	Assignment
01 : 00	ST32000641AS	SATA 6G	2000,39	N
02 : 00	ST32000641AS	SATA 6G	2000,39	N

Press Ctrl-Y to delete the data in the disk!
Or press any other key to abort...

Installing RAID Driver

New Operating System Installation

The following details the installation of the drivers while installing operating system.

1. During the operating system installation, after selecting the location to install Windows click on **Load Driver** button to install a third party RAID driver.
2. When prompted, insert the **AMD RAID Driver** disk (optical drive or USB) and press Enter.



Important

Please follow the instruction below to make an **AMD® RAID Driver** for yourself.

- Insert the MSI Driver Disc into the optical drive.
 - Click the **Browse CD** on the Setup screen.
 - Copy all the contents in `\\Chipset\WIN7\Packages\Drivers\SBDrv\SB9xx\RAID`
 - The driver diskette for AMD® RAID Controller is done.
3. You should be shown a list of available SCSI Adapters.
 4. Select the appropriate RAID controller and press **ENTER**.
 5. The next screen should confirm that you have selected the RAID controller. Press **ENTER** again to continue.
 6. You have successfully installed the RAID driver, and Windows setup should continue.
 7. Leave the disk/ USB drive in the computer until the system reboots itself. Windows setup will need to copy the files after the RAID volume is formatted, and Windows setup starts copying files.

Existing Windows Driver Installation

1. Insert the MSI Driver Disc into the optical drive.
2. The Disc will auto-run and the setup screen will appear.
3. Under the **Driver tab**, click on AMD chipset drivers by your need. The AMD chipset drivers includes RAID Driver.
4. The drivers will be automatically installed.

Confirming Windows Driver Installation

1. From Windows, open the Control Panel from My Computer followed by the System icon.
2. Choose the **Hardware tab**, then click the Device Manager tab.
3. Click the **+** in front of the RAID Controllers hardware type. The driver AMD RAID Controller should appear.

Installing Operating System on 2.2TB RAID

If you plan to install 64bit operating system on a RAID volume greater than 2.2TB, you can only manually create and load the RAID array in EFI shell.



WARNING

Create raid array will erase all the data stored on hard drives! Make sure to back up your files! There is no way to reverse the process!

The following describes an example of how to install Windows 7/ 8 64bit on a RAID 0 volume greater than 2.2TB.

1. Access **BIOS > SETTING > Advanced > Integrated Peripherals** submenu.
2. Set the **SATA Mode** option to **RAID Mode**.
3. Set the **Board SATA RAID ROM** option to **UEFI DRIVER**.

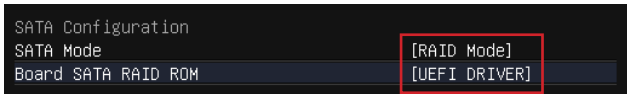

4. Save and then reboot. Press **F11** while system booting to access boot device selecting menu.

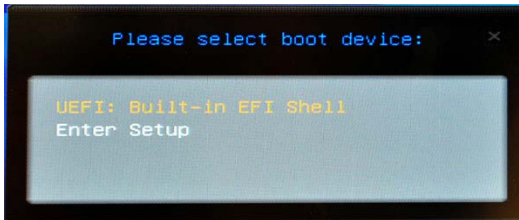

5. Select **UEFI: Built-in EFI Shell** to access the EFI Shell environment.
6. Type **drvcfg** at the EFI shell prompt, it will show values of current configurable items.

```
Shell> drvcfg
Configurable Components
Drv[40] Ctrl[B2] Lang[eng]
```

7. Refer to the value in [Drv] and [Ctrl], Type example **drvcfg -s 40 b2**.

```
Shell> drvcfg -s 40 b2
```

8. The RAID ROM will be loaded.

9. Delete all logical drivers by selecting **Logical Driver Main Menu > Logical Driver Delete Menu**.



10. Make sure there are not any logical drivers (as shown below).

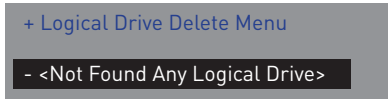

11. Back to **Logical Driver Main Menu** and select **Logical Driver Create Menu**.



12. Select **Usable Physical Drive List**.

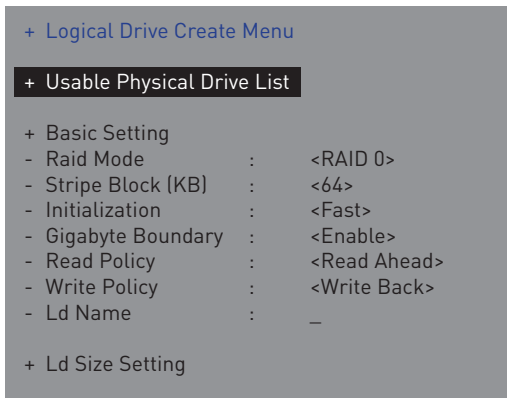

13. Choose RAID member disks by pressing arrow key and space key.

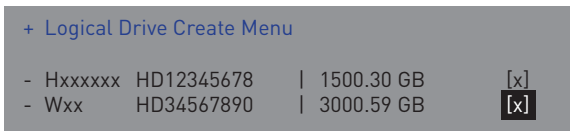

14. Back to **Logical Driver Main Menu** and fill **Ld Name**.

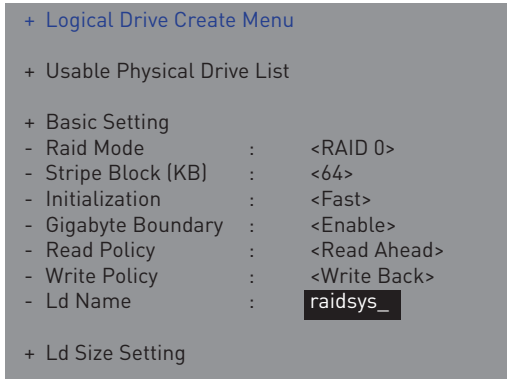

15. Select **Ld Size Setting > Start to Create**.

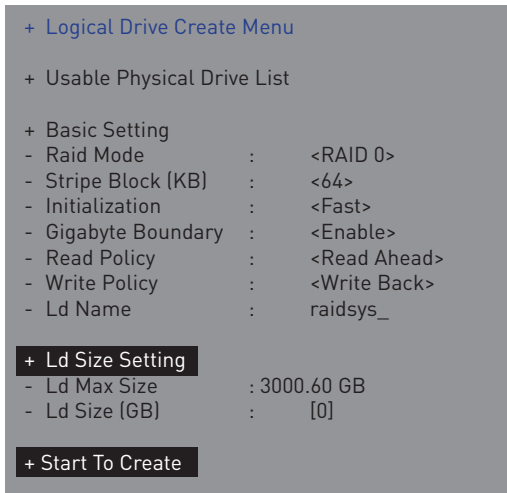

16. When prompt **Are You Sure To Create Logical Drive?** press Enter to confirm it.

Are You Sure To Create Logical Drive?
'Enter' Key - YES / 'Esc' Key - NO

17. When prompt **Successful To Create Logical Drive** press **Enter** to continue.



Successful To Create Logical Drive
'Enter' Key - Continue

18. Exit RAID ROM by pressing **F10**. When prompt **Are you Sure To Exit** press **Y**.



Are You Sure To Exit? [y / n]

19. After exiting RAID ROM, system will prompt you to restart computer (shown as below). Insert Windows 7/ 8 64bit DVD into the DVD drive. Press Enter to reboot.



Drv[40] Ctrl[B2] Lang[eng] - Options Set.
Press [ENTER] to restart platform

20. Press **F11** while system booting to access boot device selecting menu.
21. Select DVD drive that contain Windows 7/ 8 64bit DVD. System will start the Windows 7/ 8 64bit installation by booting from the Windows 7/ 8 64bit DVD.

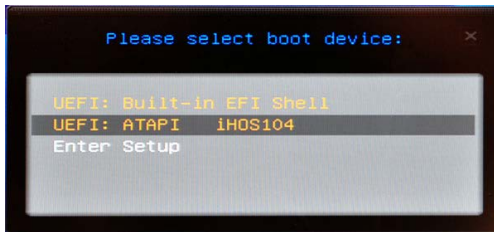

22. When require HDD driver, insert a USB flash drive that contain AMD RAID driver into a USB 2.0 port (not USB 3.0 port) and click Browse.

 **Important**

You can find the AMD RAID driver from MSI Driver Disc. The path is

\\Chipset\WIN7\Packages\Drivers\SBDrv\SB9xx\RAID

Please copy all the files in the folder to a USB flash drive.



23. Select **Removable Disk** from Browse for Folder dialog then click OK.

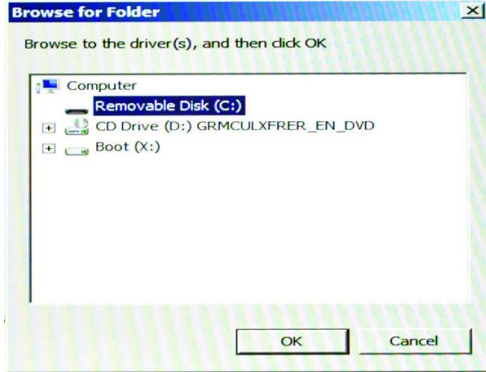

24. Install **AMD AHCI Compatible RAID Controller**.

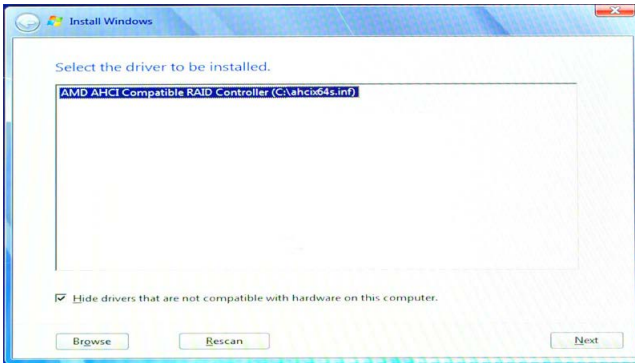

25. Windows 7/8 64bit can find the RAID volume now. Please continue the installing procedure.

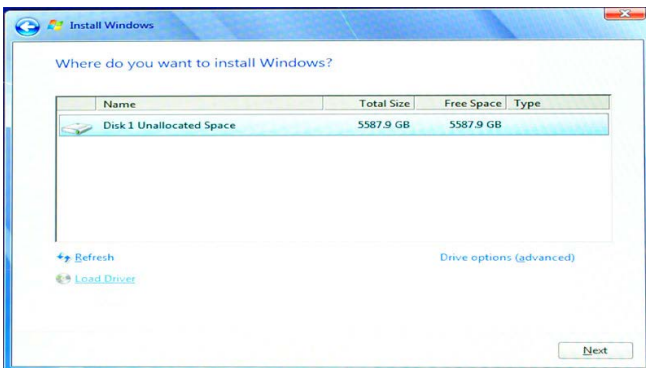

Troubleshooting

Before sending the motherboard for RMA repair, try to go over troubleshooting guide first to see if your got similar symptoms as mentioned below.

The power is not on.

- Connect the AC power cord to an electrical outlet securely.
- Check if all ATX power connectors like **ATX_PWR1**, **CPU_PWR1** is connected from the power supply to the motherboard?
- Some power supply units have a power button on the rear side, make sure the button is turned on.
- Check if the power switch cable is connected to **JFP1** pin header properly.
- Verify the **Clear CMOS** jumper **JBAT1** is set to **Keep DATA**.
- Test with another known working power supply of equal or greater wattage.

The power is on, but no signal to monitor

- Connect the monitor power cord to a electrical outlet securely.
- Make sure the monitor is turned on.
- Select different inputs on the monitor.
- If 3 long beeps are heard, remove all memory modules and try to install only one memory module in the **DIMMA1** slot first and then restart the computer.
- If 1 long 2 short beeps are heard, remove and reinstall the graphics card and then restart the computer.
- Test with another known working graphics card.

The computer does not boot after updating the BIOS

- Clear the CMOS.
- Use the secondary BIOS to bootup the system (Only for motherboard with Dual BIOS)

Lost BIOS password

- Clear the CMOS, but that will cause you to lose all customized settings in the BIOS.

There is no audio

- Adjust the volume.
- Connect the speakers/headphones to audio ports on the motherboard rear IO panel.
- Remove secondary speakers/headphones, HDMI cables, USB audio devices.
- Test with another known working speaker or headphone.

There is no network

- Make sure the network chipset driver has been installed.
- Verify if the network cable is properly connected and make sure the LAN port LEDs are properly illuminated.
- Verify your TCP/IP settings.
- Restart or reset your router.
- Test with another known working LAN cable.

The USB device is not working

- Make sure your USB drive driver has been installed.
- Verify if USB device is listed in Windows® Device Manager.
- Connect the USB device to other USB port on the motherboard rear IO panel.

Regulatory Notices

FCC Compliance Statement

Note: This equipment has been tested and found to comply with the limits for a Class B digital device, pursuant to part 15 of the FCC Rules. These limits are designed to provide reasonable protection against harmful interference in a residential installation. This equipment generates, uses and can radiate radio frequency energy and, if not installed and used in accordance with the instructions, may cause harmful interference to radio communications. However, there is no guarantee that interference will not occur in a particular installation. If this equipment does cause harmful interference to radio or television reception, which can be determined by turning the equipment off and on, the user is encouraged to try to correct the interference by one or more of the following measures:

- Reorient or relocate the receiving antenna.
- Increase the separation between the equipment and receiver.
- Connect the equipment into an outlet on a circuit different from that to which the receiver is connected.
- Consult the dealer or an experienced radio/TV technician for help.

Caution: Changes or modifications not expressly approved by the party responsible for compliance could void the user's authority to operate the equipment.

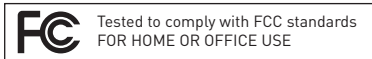

This device complies with part 15 of the FCC Rules. Operation is subject to the following two conditions: (1) This device may not cause harmful interference, and (2) this device must accept any interference received, including interference that may cause undesired operation.

CE Conformity

CE Hereby, Micro-Star International CO., LTD declares that this device is in compliance with the essential safety requirements and other relevant provisions set out in the European Directive.

Battery Information

European Union:



Batteries, battery packs, and accumulators should not be disposed of as unsorted household waste. Please use the public collection system to return, recycle, or treat them in compliance with the local regulations.

Taiwan:



For better environmental protection, waste batteries should be collected separately for recycling or special disposal.

California, USA:



The button cell battery may contain perchlorate material and requires special handling when recycled or disposed of in California.

CAUTION: There is a risk of explosion, if battery is incorrectly replaced. Replace only with the same or equivalent type recommended by the manufacturer.

Chemical Substances Information

In compliance with chemical substances regulations, such as the EU REACH Regulation (Regulation EC No. 1907/2006 of the European Parliament and the Council), MSI provides the information of chemical substances in products.

WEEE (Waste Electrical and Electronic Equipment) Statement

ENGLISH

To protect the global environment and as an environmentalist, MSI must remind you that...

Under the European Union ("EU") Directive on Waste Electrical and Electronic Equipment, Directive 2002/96/EC, which takes effect on August 13, 2005, products of "electrical and electronic equipment" cannot be discarded as municipal wastes anymore, and manufacturers of covered electronic equipment will be obligated to take back such products at the end of their useful life. MSI will comply with the product take back requirements at the end of life of MSI-branded products that are sold into the EU. You can return these products to local collection points.