

# MSD<sup>®</sup> IGNITION

# INSTALLATION INSTRUCTIONS

## Flying Magnet Crank Trigger Kit **Chrysler Big Block V8 Engines** **PN 8636**

**Important:** Read the instructions before attempting the installation.

### **Parts Included**

1 - Trigger Wheel	2 - Bolts, 5/16" - 24 x 1 1/4"
1 - Pickup Holder Assembly	3 - Bolts, 5/16"- 18 x 1 1/4"
1 - 3/4" Pickup Nut	3 - 5/16" Washers
1 - Non Magnetic Pickup Assembly	5 - Bolts, 3/8"- 16 x 1 1/4"
1 - Pickup Base	5 - 3/8" Washers
4 - Spacers	2 - Thin Spacer Washers
1 - Center Ring	Tech Bulletin #104

**Note:** On some vehicles the MSD Crank Trigger Kit may require slight modifications to accomodate special engine plates, pulley systems, etc.

### **INSTALLING THE PICKUP AND BRACKET**

1. Mount the pickup holder onto the bracket using the two fine thread bolts (Figure 1). The pickup base will only install one way, do not try to force the bolts in, and hand tighten the bolts.
2. Install the bracket onto the engine. The bracket may be mounted on either side of the balancer. Be sure to use the correct length bolts and shims in the proper location.
3. Install the pickup and locknut into the holder. Do not tighten the locknut at this time.

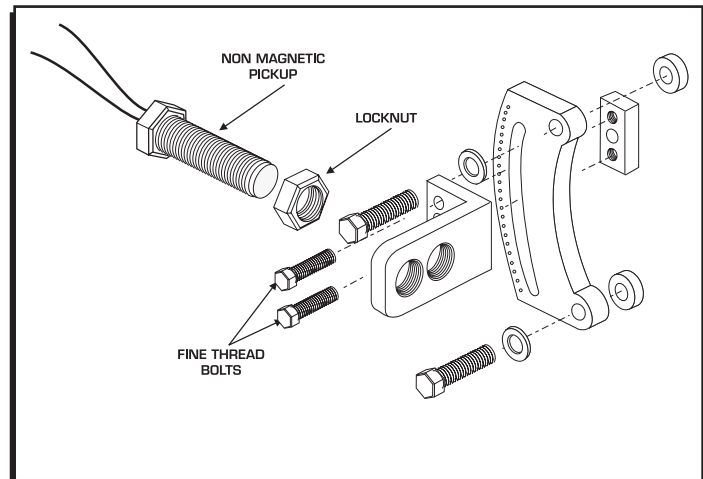

**Figure 1 Pickup Bracket Assembly.**

**INSTALLING THE TRIGGER WHEEL**

1. Position the No. 1 cylinder under compression at the desired total timing. Install the trigger wheel centering ring onto the harmonic balancer of the engine.
2. Position the trigger wheel onto the harmonic balancer and centering ring so one of the four magnets lines up with the center of the non magnetic pickup. Make sure the wheel is mounted so it rotates in the direction of the arrow on the wheel. If necessary, slide the pickup in its mount until it properly lines up with the trigger wheel magnet.
3. Check and make sure the wheel is positioned correctly with the pickup and torque the trigger wheel bolts to 25 - 30 lb-ft. The pickup should be centered to the edge of the trigger wheel (Figure 2). If not, it may be necessary to add or delete shims to the pickup bracket to achieve the proper position.

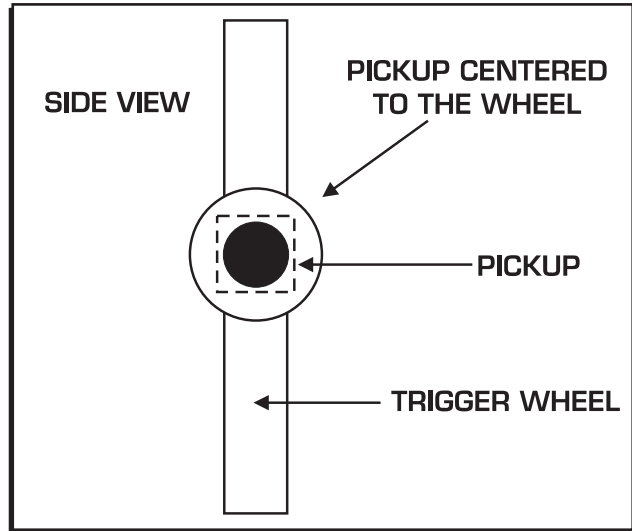

**Figure 2 Pickup Centered on the Trigger Wheel.**