

# MSD<sup>®</sup> IGNITION

# INSTALLATION INSTRUCTIONS

## Automatic Coil Selector PN 8210

**IMPORTANT:** Read instructions before attempting the installation.

### Parts Included In This Kit:

- 1 - Coil Selector
- 2 - Mounting Screws

**WARNING:** High voltage is present at the Coil Selector when the engine is running. Do not touch!

The Automatic Coil Selector will switch the high voltage output from one coil to the other on redundant ignition systems. It can be used with MSD 6 Series Ignition Controls, GM Ignition (PN 10037378), Ford Ignition (PN M-12199-B351) and Mopar Performance Ignition (PN P4876730 and P4876728).

**Note:** MSD 7 Series Ignitions cannot be used with the Automatic Coil Selector.

The Coil Selector can be mounted in the engine compartment. Make sure the secondary coil wires reach the towers. Position the Coil Selector on a flat surface and mark the mounting hole locations. Remove the unit, drill the mounting holes using a 1/8" bit and secure the Selector.

### ACCESSORIES FOR DUAL IGNITION SYSTEMS

- 90° Spark Plug Wire Boots and Terminals – Kit of nine, PN 8850. Kit of two, PN 3311
- Blaster Coil Socket Boot and Terminal, PN 3331
- Single Pole, Double Throw Switch, PN 8807
- Tach Signal Splitter, PN 8911

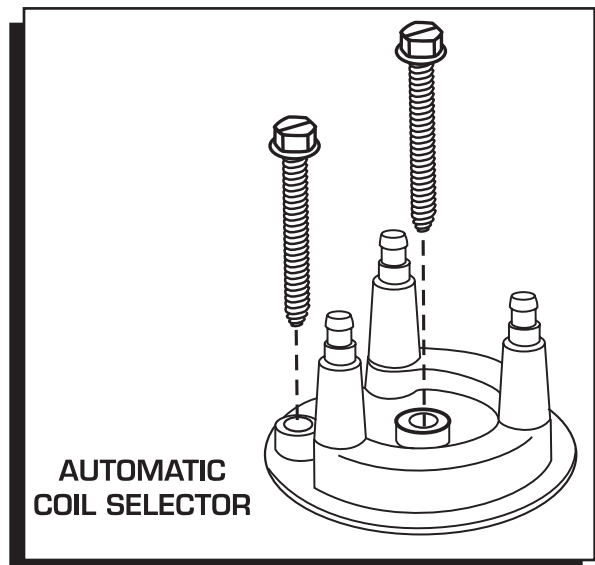

**Figure 1** Mounting the Coil Selector.

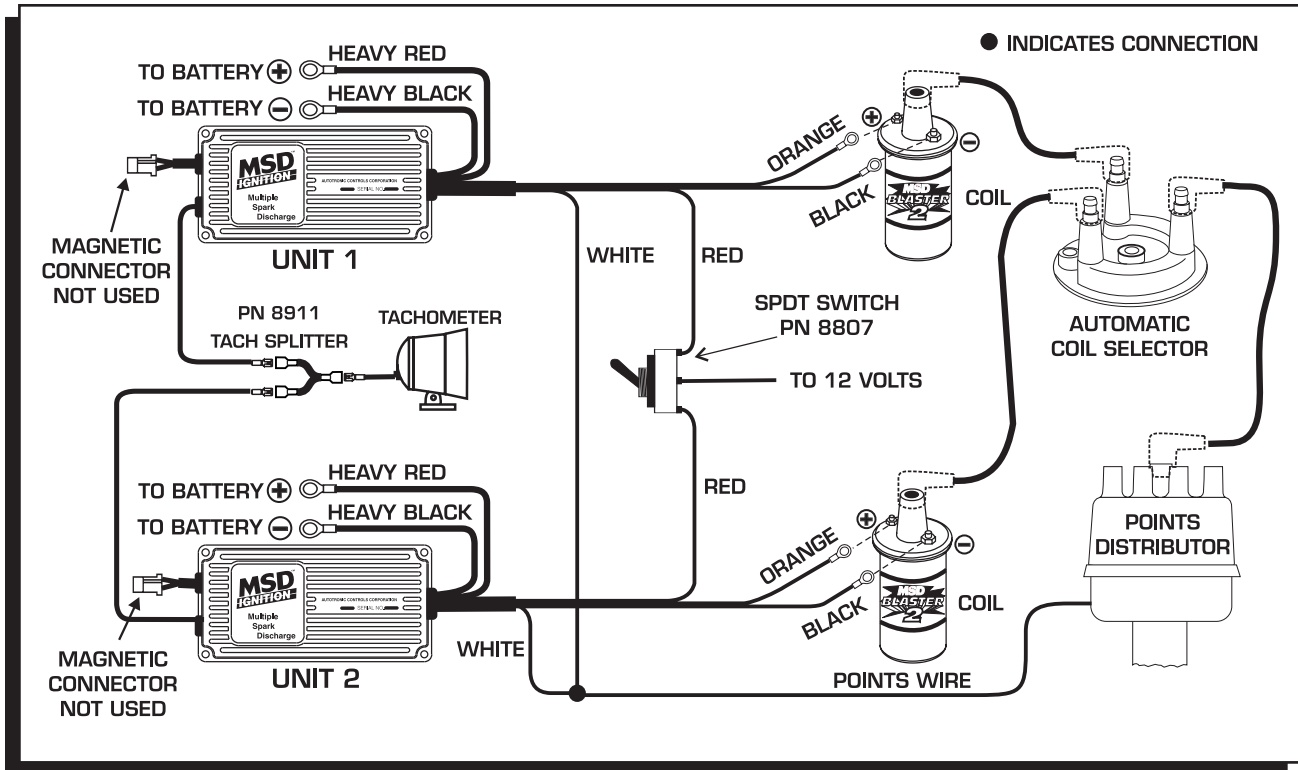

Figure 2 Two MSD 6 Series with a Single Points Distributor.

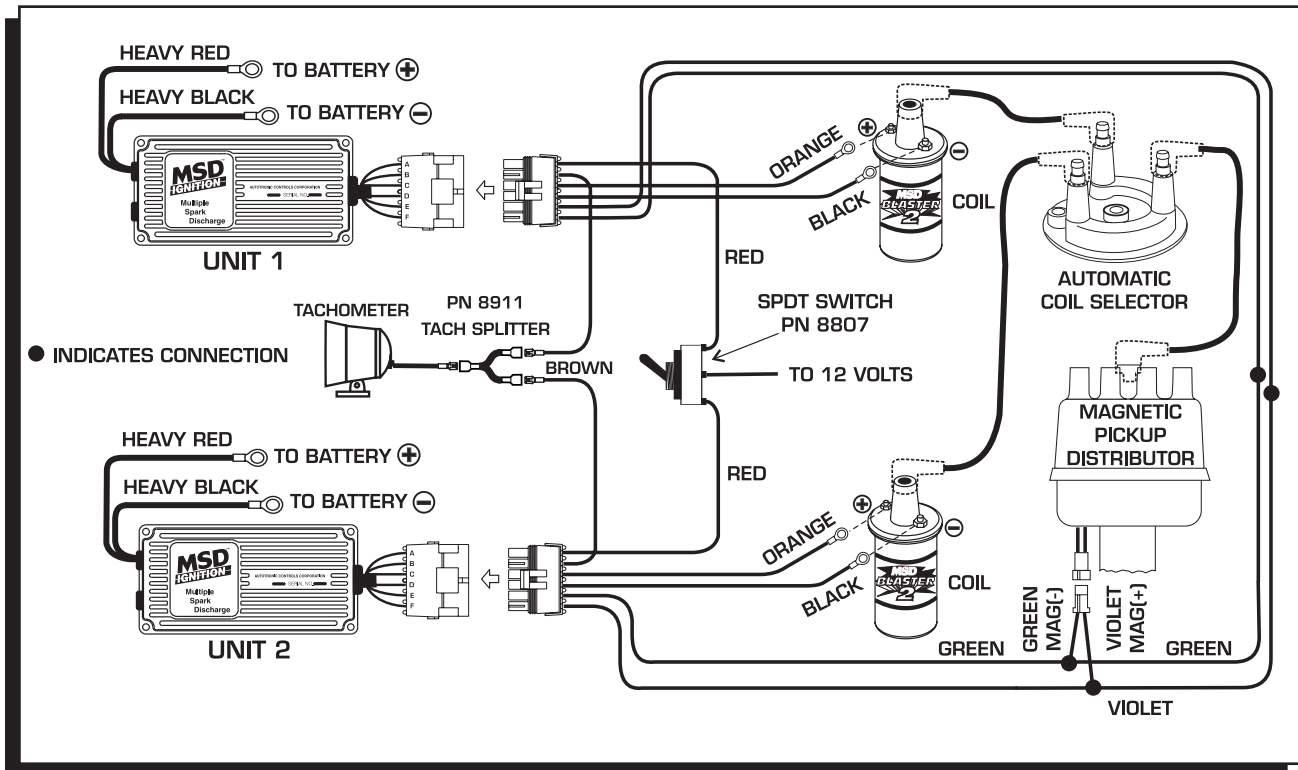

Figure 3 Two MSD 6 Series and Coils with a Single Magnetic Pickup Distributor.

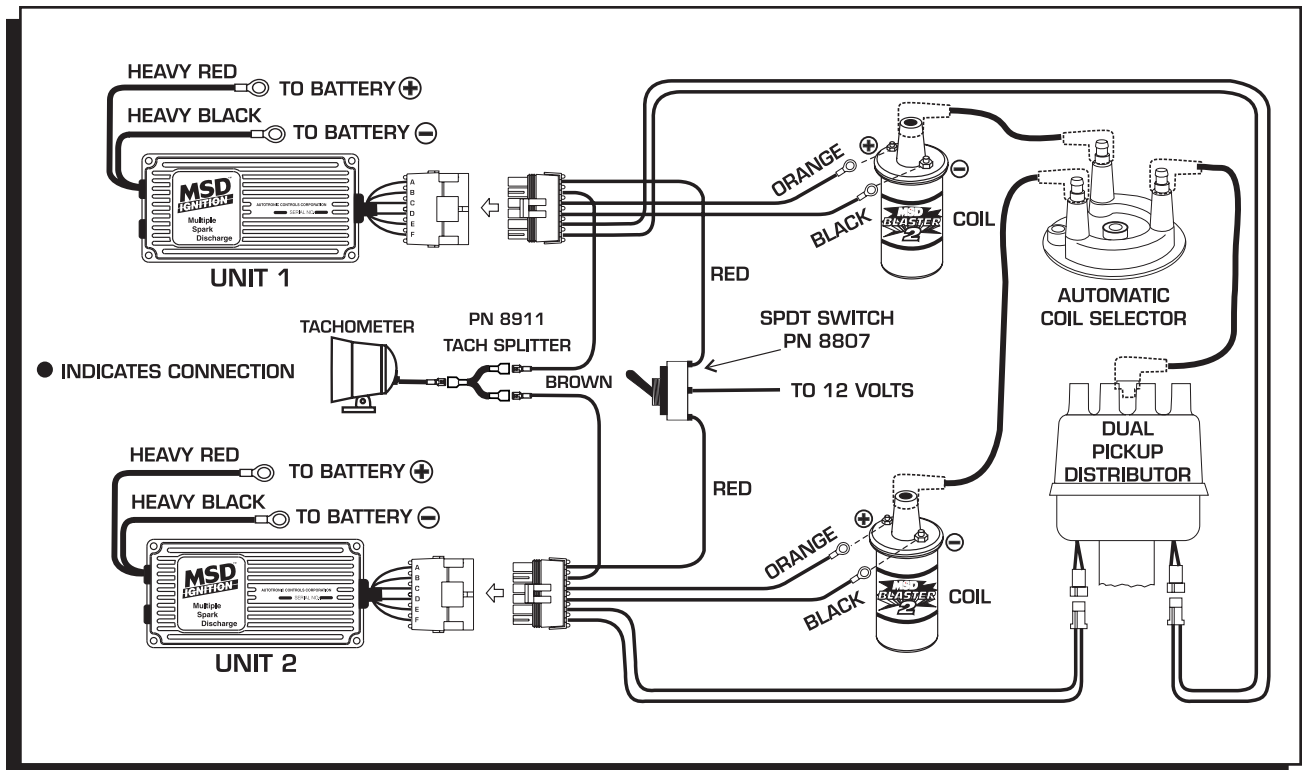

Figure 4 Two MSD 6 Series and Coils with a Dual Magnetic Pickup Distributor.