

INSTALLATION INSTRUCTIONS

Atomic EFI **PN 2910 - Throttle Body Kit**

Thank you for selecting the Atomic TBI Fuel Injection System! MSD's Atomic EFI systems were designed with two major goals; to simplify EFI and deliver better overall performance to your engine. Simplicity is achieved through with less wiring to ease installation plus programming is simple with no PC required! Performance is delivered through advanced control of the fuel and ignition, just as you'd expect from MSD.

As with any performance product, please be sure to read the entire instruction manual before attempting to install this system on your vehicle.

Parts Included:

1 - Throttle Body w/ECU	1 - O ₂ Sensor	4 ft. CAN Extension
1 - TB Harness	1 - O ₂ Bung and Plug	Air Filter Gasket
1 - Power Module	4 - Rubber Grommet	Intake Manifold Gasket
1 - PM Harness - w/ WBO ₂	4 - Eyelet Insert	1 - Fitting 6AN Adapter 6 Male
1 - Handheld Monitor	4 - Mounting Screws	
1 - Coolant Temp Sensor	1 - 4G Micro SD Card	

The Atomic Throttle Body EFI system, PN 2900 and PN 2910, have been granted Executive Order number D-722 from the California Air Resources Board. This E.O. number permits the installation of the Atomic TBI system on 1987 and older GM passenger cars and trucks with a V8 gasoline powered engine originally equipped with a carburetor. Other vehicles and manufacturers are pending approval.

For emission compliant installation, all of the original control components must be retained including the catalytic converter, EST distributor, AIR pump, EGR, etc. An addendum outlining specific installation steps and settings for a CARB compliant installation are included separately with this kit.

⚠️ WARNING

Installation of this product requires detailed knowledge of automotive systems and repair procedures. Installation of fuel system parts and any fuel tank modifications must be carried out by a qualified automotive technician. Installation of fuel system parts requires handling of gasoline. Ensure that work is performed in a well ventilated area with an approved fire extinguisher nearby. Extinguish all open flames, prohibit smoking and eliminate all sources of ignition in the area of the vehicle before beginning the installation.

When working with fuel systems, eye goggles and other safety apparel should be worn to protect against debris and sprayed gasoline. The finished work must be thoroughly checked to ensure there are no fuel leaks.

CONTENTS:

Parts Review and System Capabilities	2	Programming	
Fuel System Overview and Requirements . .	3	Initial	12
O ₂ Sensor Installation	5	Advanced	13
Throttle Body Installation	6	Final Adjustments	15
Power Module Installation and Wiring	9	Diagnostics	20
Throttle Body Wiring	7, 10-11		
System Wiring	9-11		
Wiring with Timing Control	16-18		

CAPABILITIES

The Atomic TBI is designed to install on a standard square bore intake manifold flange. It is a self-tuning EFI system that continuously adjusts after the basic configuration is complete. There is no laptop programming. Based on the engine descriptors that you input during the initial setup, the Atomic will automatically create a base fuel map to get the engine running. Once the system is started the self-learning technology will optimize those maps resulting in the best performance possible. If you drive through altitude changes, temperature swings or other factors the Atomic will adjust accordingly, on the fly. This ensures that your engine will produce excellent driveability at all times, even from the sunny coast to the cool mountains.

There are three main components of the Atomic TBI; the throttle body, the Power Module and the Handheld Monitor. The ECU of the system is built into the passenger side of the throttle body and there are several sensors integral to the unit including the Throttle Position Sensor (TPS), Manifold Absolute Pressure (MAP), Intake Air Temperature (IAT) and the Fuel Pressure Sensor.

Power Module: The Power Module of the Atomic LS is the communication hub of the system and provides the high current fuel pump circuit and other input/outputs for optional features. The unit has two ports for the MSD CAN system as well as a wiring harness. There are connections for the WB02, the Handheld Monitor as well as power and communication to the integrated fuel rails.

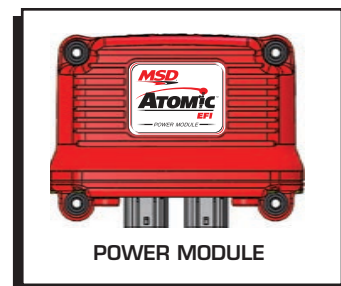

Programming: To program the Atomic for your specific engine application, there is no need (or method) to connect a PC to the system. All of the programming is performed through a simple to use Handheld Monitor. The Monitor simply plugs into the Power Module. Once the few initial setup selections are answered and the engine is running the Monitor can be removed or left connected. When it is connected, there is a Dash and Gauges screen that shows engine parameters in real time.

Fuel System: The Atomic TBI system can be used with return or returnless EFI system. Review the Fuel System Information section starting on page 3 for detailed information.

Wide-Band O2 Sensor: A Wide-Band O2 sensor is supplied in the Atomic TBI Kit. This sensor is responsible for constantly monitoring the exhaust gases and relaying that information to the ECU where adjustments are continually made to the fuel delivery in order to meet the air/fuel targets. Only one sensor is required. Page 5 outlines sensor installation.

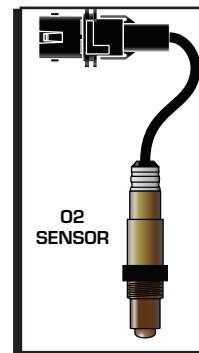

Trigger Signal: The Atomic TBI requires an rpm/trigger reference signal to operate. This signal can be a 12-volt square wave reference signal from the tach output of an MSD ignition control or it can be achieved when connected to coil negative with breaker points, GM HEI or Ford TFI inductive based ignition system.

Timing Control: The Atomic TBI is capable of controlling the ignition timing. To use this function an MSD 6A or other ignition control must be installed. The distributor must also be locked-out. There are settings for Idle timing, Total advance and Vacuum advance through the handheld monitor. Pages 16-19 explain the timing control setup in detail.

Rev Limiter: A fuel controlled rev limiter can be set through the Atomic. When the engine rpm reaches the programmed value, fuel will be cut off to achieve the desired limit. Any ignition related rpm limit is set and acts independently of the Atomic.

Power Adders: The Atomic TBI can operate in conjunction with wet nitrous systems as well as positive manifold pressure supplied by a draw-thru or blow-thru forced induction system. For nitrous, there is a program that allows you to set a target air/fuel ratio when the nitrous is activated as well as a selection to retard the timing (when timing control is incorporated) Note that a wet nitrous system requires its own fuel pump to supply the additional fuel required with nitrous.

For forced induction applications there is a target air/fuel ratio setting which takes effect when operating under boost. These options are explained in the Advanced Settings section, page 13.

FUEL SYSTEM REQUIREMENTS

The following details pertain to the fuel system requirements. Installation steps specific to the fuel system are covered in the Fuel Pump Kits supplied separately from the Atomic TBI, PN 2910, Kit.

The Atomic TBI requires a high pressure fuel pump system. Depending on your engine combination, the Atomic TBI requires a minimum of 42-48 psi to operate and it can be used with a return or returnless fuel system. When selecting a pump, regulator and lines, be sure each component is designed to perform at high pressure. MSD offers a fuel pump, hose and accessories to complete your installation. Following are some guidelines in helping set up a fuel system for your Atomic as well as components available separately from MSD.

- The Atomic is capable of operating with a return or returnless style system. For best results, MSD strongly recommends an in-tank pump. Installing the fuel pump in the tank results in quieter operation, less chance of cavitation and a reduction in pump temperature.
- When running a returnless fuel system (Pulse Width Modulated), it is strongly recommended to install the pump in the tank. It is recommended to use an MSD Atomic Fuel Pump, PN 2925 or PN 2926.
- If mounting the pump in the tank is not an option, install the pump as close as possible to the tank. Within 2-feet of sending unit is recommended.
- Do NOT use hard line when plumbing the fuel system. When using a PWM fuel system, cavitation could cause unstable fuel pressure resulting in poor engine performance.
- When used, an adjustable regulator must be installed on the return side of the throttle body.

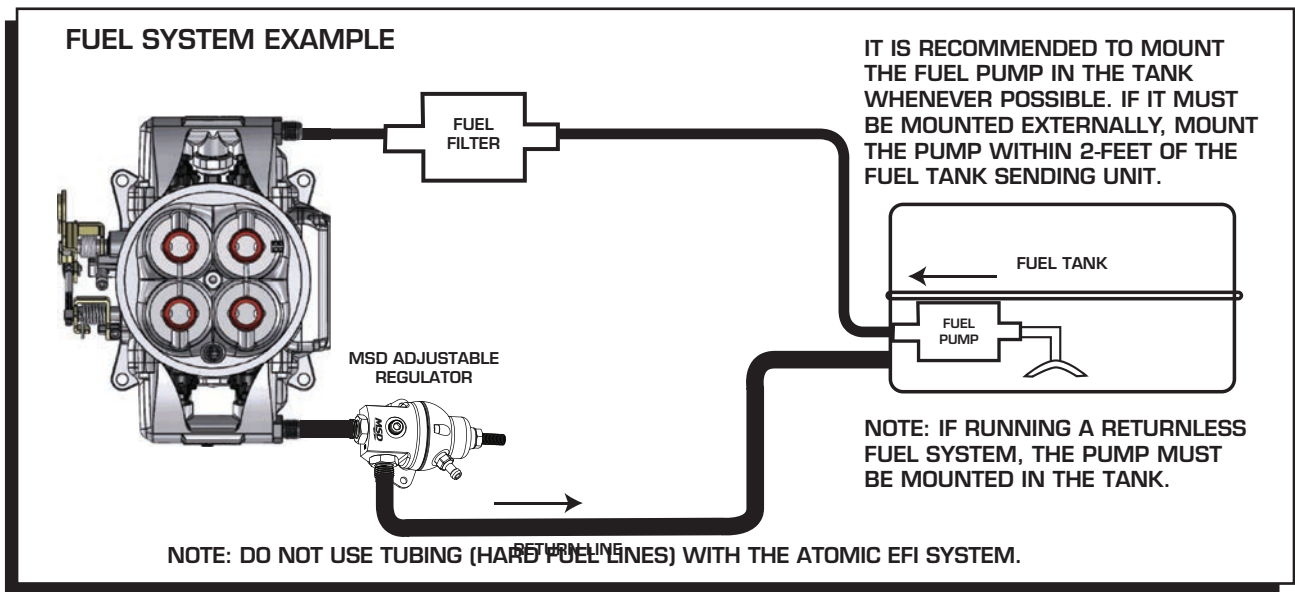

Figure 1 Atomic Return Style Fuel System.

WARNING: MSD’s Push-Lock fittings are designed for use with the MSD fuel hose only. Do not use the MSD fuel hose with other fittings. Do not use MSD Push-Lock fittings with other fuel hose. Compatibility issues may cause fuel leaks.

IN-TANK PUMPS

The MSD Atomic Fuel Pump (supplied only with Master Kit PN 2900) can be used in the tank however it would require a sock, or filter element, on the pickup side (Figure 1). It is important to note that the wiring used to run the pump will need to meet requirements to be submerged in fuel. When wiring an in-tank pump, it is recommended to use a wire that conforms to SAE specifications J1128 and J378. This wiring features a thermoplastic insulated wiring with polyvinyl chloride insulation for protection against gasoline, oil, and more.

In addition, different fuel line will be required internally if the pump is to be mounted in the tank. Fuel line that meets SAE 30R10 specifications MUST be used. Failure to do so will cause severe damage to your engine and/or fuel system.

WARNING: Improper installation or use of fuel system components can cause severe damage your engine and/or fuel system that will not be covered by the manufacturer's warranty.

Atomic Fuel Pump, PN 2925: This pump features 3/8" inlet and outlet and is rated at 70 psi. The pump will support approximately 525 hp and is approved for in-tank use (no wiring or in-tank mounting hardware/pickup element are supplied).

Fuel Pump Kit, PN 2920: This Kit is supplied with MSD's PWM Fuel Pump, a pre- and post-filter, 15-ft of 3/8 fuel injection line and mounting hardware.

Fuel System Return Kit, PN 2922: If you plan on running a return line with your Atomic LS, this kit provides another 15-ft of 3/8" injection line, an MSD Regulator and two push-lock fittings.

High Horsepower Fuel Kit, PN 2921: This pump will support the power demands of engines up to 650 horsepower. The pump features 3/8" inlet and outlet and is rated at 70 psi. The pump will support approximately 650 hp and is approved for in-tank use (no wiring or in-tank mounting hardware/sock are supplied).

POWER ADDERS

The Atomic TBI will accept wet nitrous systems as well as forced induction systems generating up to 10-14 psi of manifold pressure. There are options to select in the Advanced settings that allow you to program an air/fuel target when the nitrous is activated and when under boost conditions.

Nitrous: The Atomic fuel system does not provide the extra fuel required to safely operate a wet nitrous system. The installation of a dedicated fuel pump for the nitrous system is required in order to meet the fuel demands of a wet nitrous system. Timing can also be pulled out when the nitrous is activated (only when timing is being controlled by the Atomic system.)

Forced Induction: In boosted applications, the fuel pump must be capable of meeting the requirements of the increased fuel demand. Due to injector flow limitations, max horsepower with forced induction systems will be limited to 525 horsepower. Proper fuel pump selection is imperative to the performance and operation of the Atomic EFI.

WIDE BAND OXYGEN SENSOR INSTALLATION

The MSD Atomic EFI system requires a single Wide Band Oxygen Sensor (WBO2) for operation. MSD suggests that the bung for this sensor be installed prior to starting any other part of the conversion process. By having the WBO2 in place first, there is a reduced chance of the vehicle being immobilized for an extended time. The bung for the WBO2 provided by MSD has a plug included so that the vehicle can be driven between the time of exhaust modification and installing the rest of the Atomic system, if needed.

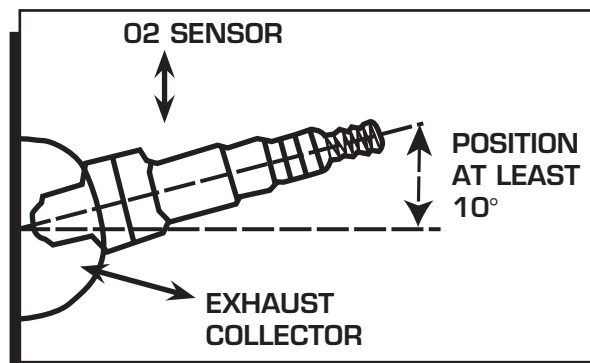

Figure 2 WBO2 Sensor Location.

The WBO2 can be installed downstream of either exhaust bank. The sensor connects to the Power Module, so install the sensor on the bank closest to where you plan to mount the Module. The bung should be installed by a qualified exhaust technician and pressure tested. Proper installation of the oxygen sensor is critical to the performance of the Atomic EFI. Improper installation could lead to engine damage.

1. Locate the ideal spot to install the WBO2.
 - a. This location should be 2-4 inches after the exhaust collector. The sensor must be more than 18 inches forward of the exhaust tip. For applications where short or open headers are used, install the WBO2 in the primary tube of the rear cylinder at least 8 inches away from the exhaust port. The Atomic will not work on “Zoomie” style headers.
 - b. The WBO2 sensor should be at least 10° above horizontal to allow condensation runoff. Without this angle the sensor is significantly more likely to sustain water damage (Figure 2).
 - c. Never place a WBO2 on the outside of a bend.
 - d. The WBO2 **must** be mounted in the exhaust prior to any catalytic converter, if applicable.
2. Drill a 7/8” hole in the exhaust where the WBO2 will go.
3. Weld in the supplied bung. Ensure the weld goes completely around the bung and is air tight.
4. Insert supplied plug in bung. Never run the vehicle with a WBO2 installed but not powered; it will damage the sensor.
5. When completing the Atomic EFI installation, remove the plug and insert the WBO2 for use. MSD suggests using a small amount of anti-seize on the threads.

Note: The Atomic EFI is extremely sensitive to air leaks in the exhaust system. Any air leak between the engine and the WBO2 will cause the Atomic to have false readings, which can lead to poor engine performance, misfires, and an inability to properly auto-tune. Extended running of the Atomic EFI with an exhaust leak can result in detonation and severe engine damage. Improper installation of the oxygen sensor, and any damage that may result from such an installation, is not covered by the manufacturer’s warranty.

THROTTLE BODY

Parts Required, not included:

- 4 – Retaining Stud Kit for the throttle body
- Throttle linkage connection/brackets

The Atomic Throttle Body will bolt in place on intake manifolds designed for a square bore style carburetor. It is designed to accept common throttle linkage adapters and brackets. A throttle ball stud is supplied but no other linkage components are included. Accessory kits are available through many accessory or carburetor companies.

There are two fuel inlets, a forward and rear fuel inlet. Only one needs to be connected on a PWM (returnless) style system as fuel is delivered to either side through an internal fuel rail. The passenger side of throttle body, where the MSD is machined, is the Electronic Control Unit (ECU). This is the brains of the Atomic fuel system and where all of the fuel calculations are made to give your vehicle exceptional performance.

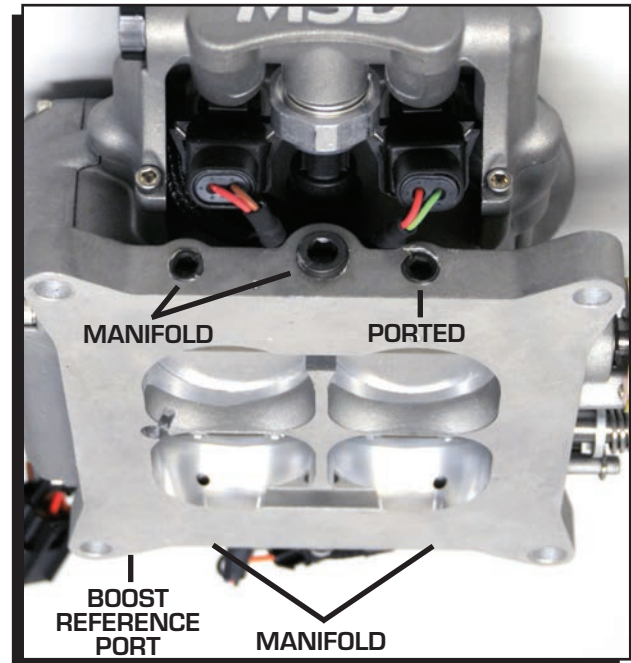

Figure 3 Vacuum Ports.

VACUUM PORTS

Before installing the throttle body, note the engine’s need for vacuum accessories. The Atomic has five vacuum ports, ported and manifold, to cover accessories such as a power brake booster (Figure 3). Four ports are 1/8” NPT and one is 1/4” NPT.

BOOST REFERENCE PORT

Blow-Thru applications do not require modifications to the boost reference port. Draw-thru applications require a few modifications to the throttle body. Locate the boost reference port on the throttle body. It is located on the lower right corner of the throttle body on the same side as the IAC motor (back of the throttle body), and remove the plug. Turn the throttle body upside down. Using a small drop of Loctite on the plug, install the plug into the threaded orifice next to the throttle blades. Install a 1/16 pipe to hose fitting into the boost reference port on the throttle body. The boost reference port on the throttle body should be referenced below the supercharger directly off of the manifold, or can be split off of the boost gauge reference line (Figure 4).

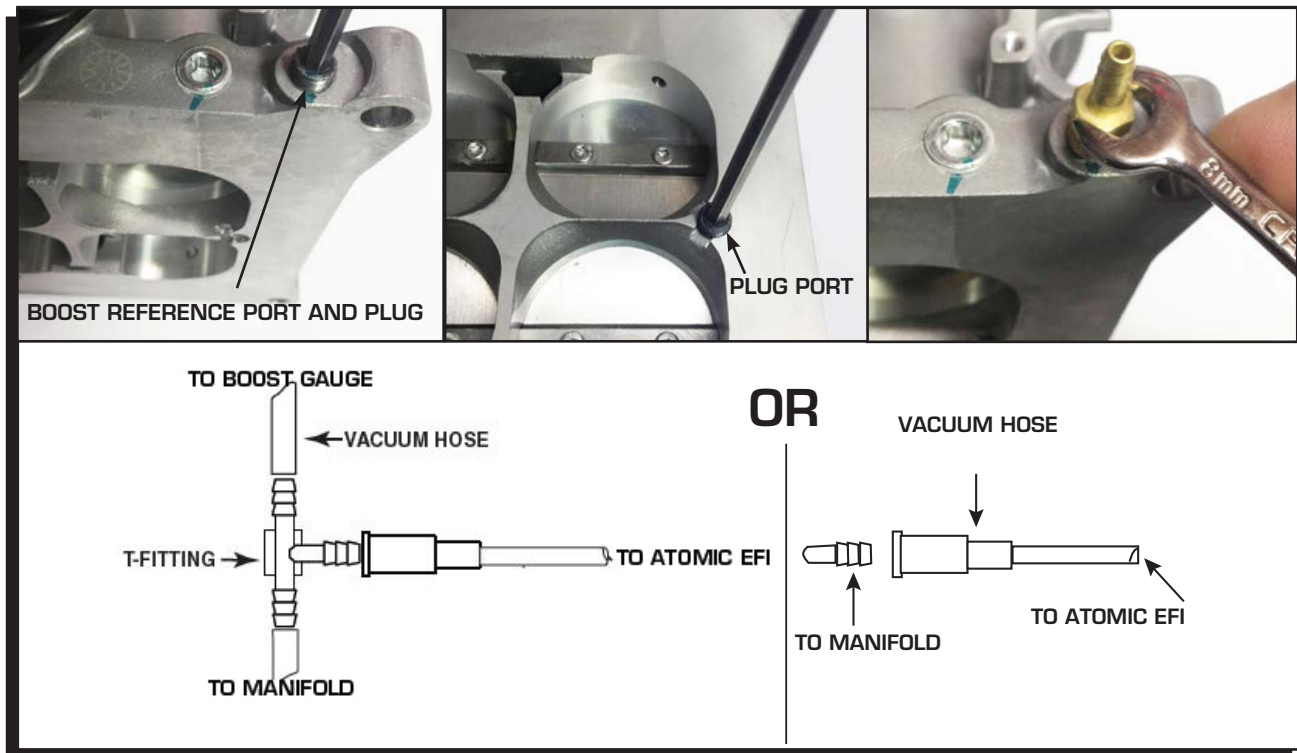

Figure 4 Boost Reference Port.

INSTALLATION

1. Install the new gasket and place the throttle body on the intake manifold. Make sure the throttle body is square on the intake and the linkage moves through closed throttle to wide open.
 2. Secure the throttle body by tightening the four retainers evenly. **Do not over tighten.**
 3. Transfer the linkage hardware from the carburetor to the Atomic. Any transmission brackets should also be transferred to the Atomic. A throttle return spring must be used (Figure 5).
 4. Install the new air horn gasket.
 5. Determine which fuel inlet and AN-fitting best suits your application.
 6. MSD supplies two -6 AN style fittings for use on the throttle body fuel inlet. Both use 'push-lock' style inlets to connect to the fuel hose and do not require clamps. Page 8 details the installation of MSD's push-lock fittings and hose.
- Note:** Not all fuel lines are rated for "push lock" installation.
7. Install the fitting to the throttle body.

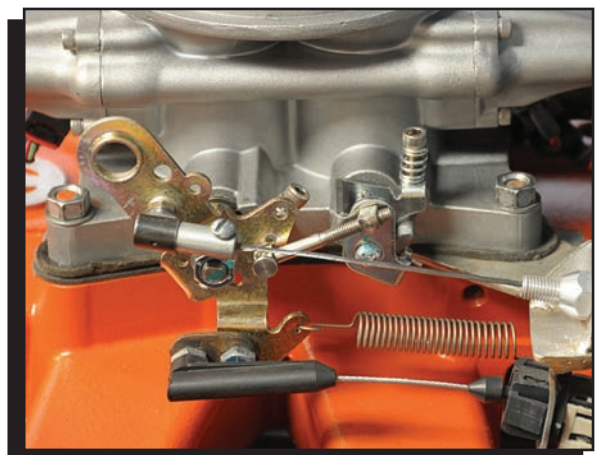

Figure 5 Throttle Linkage.

EXTERNAL SENSORS

There are only two external sensors that need to be installed and connected; the Wide Band Oxygen Sensor and the Engine Coolant Temperature Sensor. (Both are supplied.) The Wide Band Oxygen Sensor installation is covered on page 5.

The coolant sensor is a variable resistance sensor and needs to be installed in the engine.

1. Find a location for the coolant temperature sensor. Many engines have provisions on the cylinder heads or the intake manifold.
2. It is recommended to use a small amount of Teflon tape or sealer on the threads.
3. Locate the 2-pin coolant sensor wiring harness. Route and connect the harness to the coolant temperature sensor.

WIRING

There are several wires and connectors on the throttle body. Not all of these wires will be connected on every application. Following is a chart of each wire.

REQ. / OPT.	Wire Color	Description
REQ	Yellow Black	This connects to the Engine Coolant Temperature Sensor.
REQ	White	This is the tach input wire for the EFI responsible for triggering the system. It connects to the tach output of an MSD Ignition Control or Ready-to-Run Distributor. It can also be connected to the coil negative terminal when using a stock type ignition such as points or a GM HEI distributor. Note: This wire is not used when the magnetic pickup wire is being used for ignition timing.
OPTIONAL used with timing control	Yellow	This is a tach output wire. Connect this wire to the White points input wire on an MSD ignition unit only when using the Atomic to control timing. If the Atomic is not controlling timing this wire can be used as a 12 volt square wave trigger to a tachometer.
OPTIONAL used with A/C	Orange	This is an AC kick-up wire. When 12 volts are supplied to this wire it will provide a small rpm "kick-up" in the idle to compensate for an added load to the engine from the air conditioner compressor. It will also activate the primary cooling fan (when two are used).
OPTIONAL used with timing control	Violet (+) Green (-)	This is the input for a magnetic pickup, such as from an MSD distributor. This connector is only used when the Atomic is controlling ignition timing.
REQ	CAN-Bus	The 6-pin connector must connect to the Power Module. Do NOT cut this harness. MSD offers extensions in 2, 4 and 6-foot lengths if needed.

PUSH-LOCK FITTING INSTALLATION

MSD supplies two fitting adapters that will accept a -6 AN line to be connected. If you are using the MSD Push-Lock fittings to connect the fuel hose, the supplied hose **MUST** be used.

Proper installation begins with a clean, square cut of the hose. A hose cutting tool or new razor blade are recommended. When installing the hose it is important that the hose is pushed on all the way to the thin beauty ring. This means the hose should fully overlap the inboard barb. Too little of engagement, as well as over-engagement, will result in a compromised connection that is prone to failure. Figures 6 and 7 illustrate the required installation of the hose and fittings.

1. Determine the length of hose needed. Mark the hose and cut it using a hose cutter or new razor blade. There should be minimal disturbance of the outer jacket, braids and inner liner. The cut plane should be perpendicular to the hose axis. (Figure 5).
2. Before installing the hose to the fitting, it is important to anchor the fitting (Figure 6). Proper installation cannot be achieved by holding the hose and fitting in your hands. For best results, the hose should be installed with minimal twisting or pausing.
3. Apply a light coat of oil to the barbs on the fitting. Use care not to get oil on the outside of the hose as it will be impossible to get a firm grip on the hose.
4. With the fitting anchored securely, push the hose over the barbs. The hose is properly installed when it is flush with the thin edge of the beauty ring (Figure 7). At this point, the hose end should have rolled over the inboard barb.



Figure 5 Severing the Hose Properly.

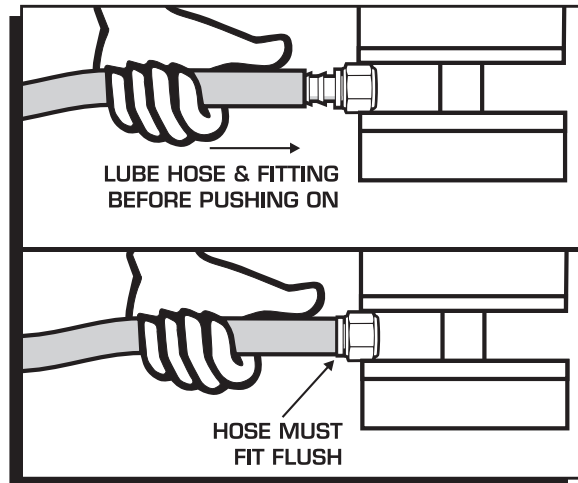

Figure 6 Installing Fuel Hose to the Push-Lock Fittings.

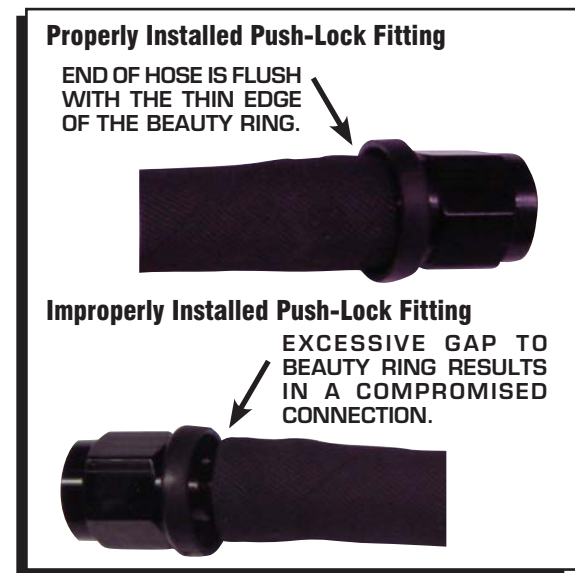

Figure 7 Installed Push-Lock Fitting.

WARNING: The supplied MSD Push-Lock AN fittings are designed only for use with the supplied fuel hose (Aeroquip AQP FC598). We do not recommend mixing Push-Lock style fittings and hoses from different manufacturers. Doing so may result in fuel leaks and expose other dangerous incompatibilities.

POWER MODULE INSTALLATION

The Power Module of the Atomic EFI system handles high current circuits such as the fuel pump and WBO2. The unit has two ports for the MSD CAN system as well as a wiring harness. The CAN ports will provide communication between the Power Module, Throttle Body, and Handheld Controller. It is important to select a proper mounting location for the Power Module. The unit can be mounted in the interior or the engine compartment as long as it is away from direct heat sources. It is not recommended to mount the unit in an enclosed area, such as the glove box, so that airflow will aid in cooling. When a suitable location is found to mount the Module, make sure all wires reach their connections. Also be sure that the CAN ports can be accessed for use of the Handheld. Use the Power Module as a template and mark the location of the holes. Use a size # 20 drill bit to prepare for the supplied self tapping screws. Install the supplied rubber grommets and mount the unit.

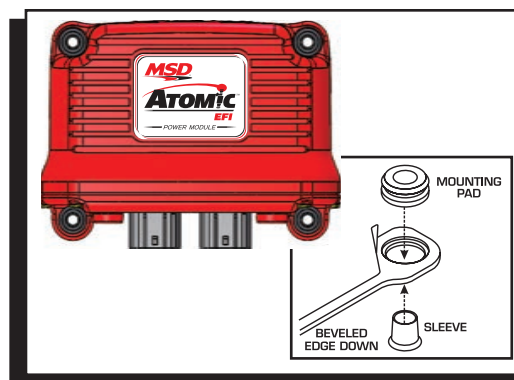

Figure 8 Power Module Wiring Diagram.

WIRING

There are a number of electrical connections on the Power Module that are required for proper operation. Other wires, such as fan control wires, only need to be connected if their optional functions are being used. Wires marked “REQ” must be connected for the system to operate while those marked “OPT” will depend on the functionality desired. Note that the two schematics shown are for installations that are NOT using the timing functions of the Atomic. At this point it is recommended to start the system without including the ignition wiring to confirm and tune-in the Atomic for your installation. If you wish to proceed with timing installation, follow the wiring below, and continue to page 16 to set up the distributor and ignition timing.

Pin	REQ. / OPT.	Wire Color	Description
1	REQ	Black	Ground - Route this wire directly to Battery Negative or the engine block.
2	OPTIONAL	Tan	Fan circuit 1 - This wire supplies ground to activate the circuit. It must go to the ground circuit of a relay to control a fan.
3	OPTIONAL	Pink	Fan circuit 2 - This wire supplies ground to activate the circuit. It must go to the ground circuit of a relay to control a fan.
4 5 6	Unused Unused Unused	(No Wire) (No Wire) (No Wire)	Unused Unused Unused
7	Optional	Violet	Nitrous Signal - When connected to 12 volts, such as when nitrous is activated, the Atomic will switch to the target air/fuel mixture for use during nitrous. The timing will also be retarded the programmed rate (when timing control is used).
8	REQ	Orange (Large)	Fuel Pump circuit - This wire provides 12 volts to the fuel pump and connects to the positive side terminal. No relay is required. Note that on a returnless style fuel system the voltage on this wire will not display on a voltmeter.
9	REQ	Red (Large)	Main Power - Route this wire directly to Battery Positive. This circuit needs to maintain power after the unit is turned off so that all Learning can be saved properly.
10 11 12 13 14 15	REQ	Red Yellow Black / White Black / Red Green Black	Wide Band Oxygen Sensor connection - single connector.
16	REQ	Red	On/Off – Connect to a switched 12 volt circuit. Ensure it has power during both Key On and Cranking. Do NOT connect the coil (+) terminal when using an MSD Ignition such as a 6A or 6AL or other CD ignition.

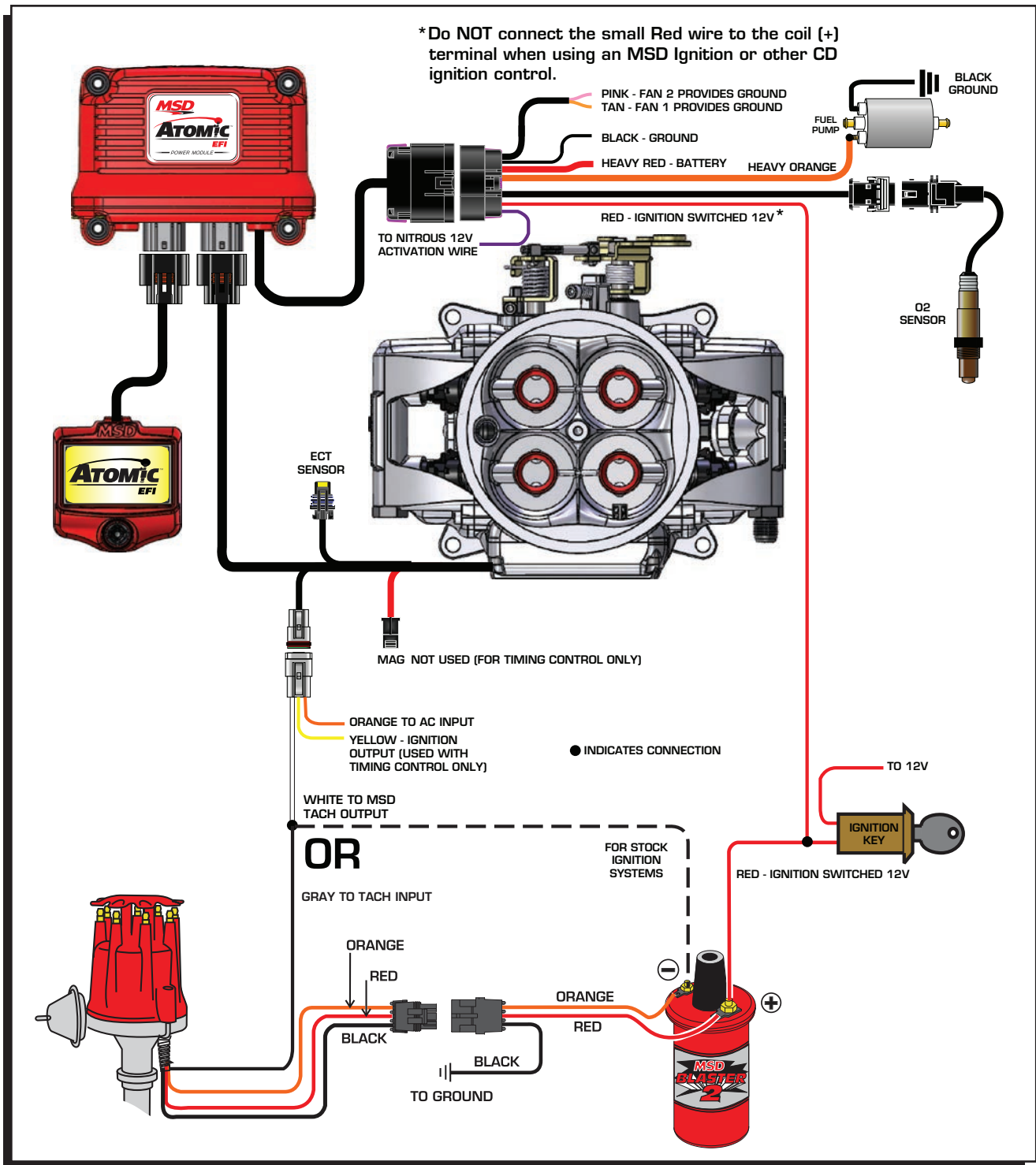

Figure 9 – Atomic Wiring with an MSD Ready-to-Run Distributor or MSD HEI Distributor.

STOP HERE

Please review the parts installed thus far. Check to see that all required wires are run properly and that the fuel system is complete and secure. The next section of instructions will require power to the Handheld. Turning on power (Key On) will prime the fuel pump. It is extremely important to check for fuel leaks at this time.

Do not attempt to start the engine until the Initial Setup has been completed on the Handheld.

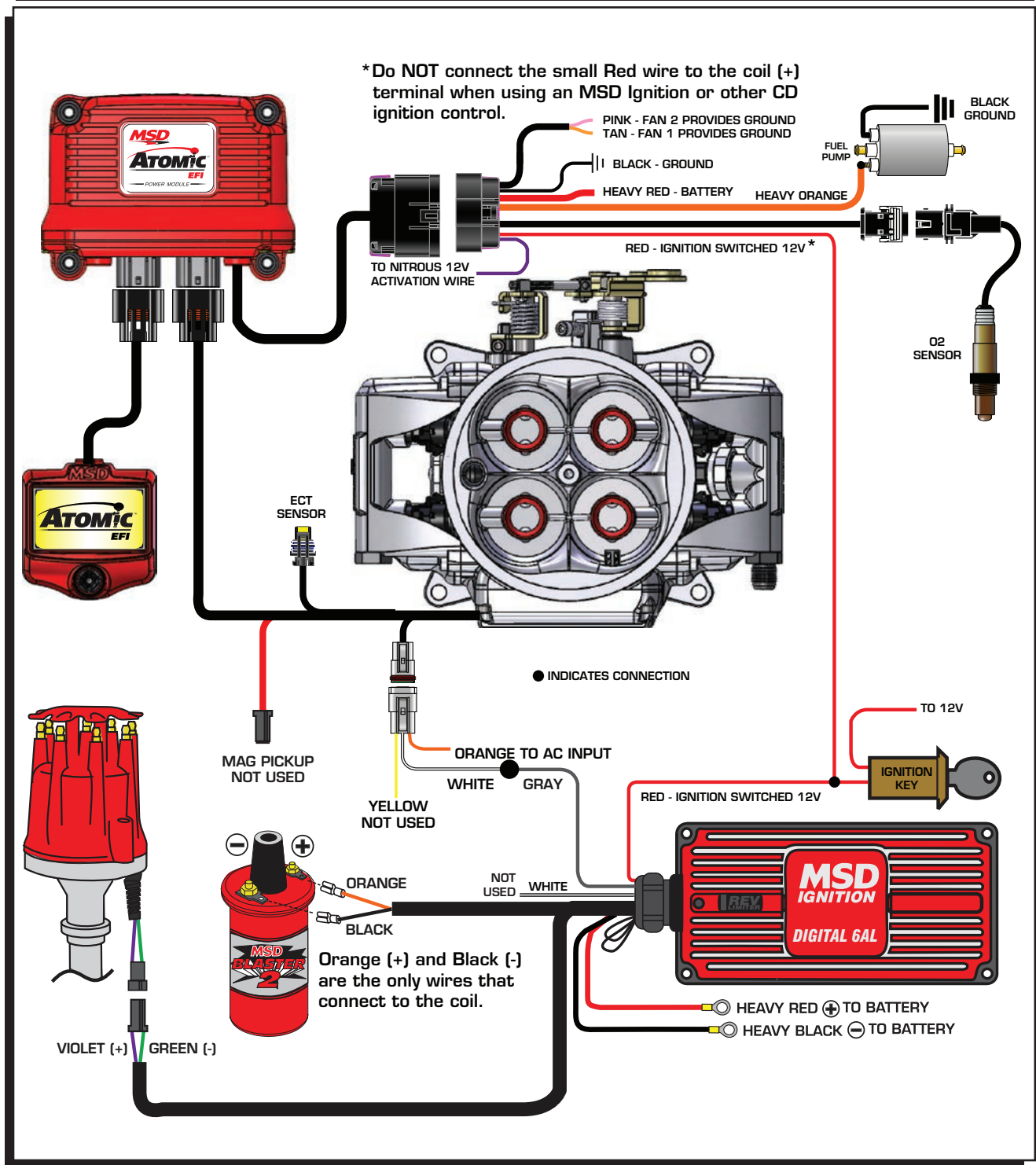

Figure 10 Atomic Wiring with an MSD Ignition Control.

STOP HERE

Please review the parts installed thus far. Check to see that all required wires are run properly and that the fuel system is complete and secure. The next section of instructions will require power to the Handheld. Turning on power (Key On) will prime the fuel pump. It is extremely important to check for fuel leaks at this time.

Do not attempt to start the engine until the Initial Setup has been completed on the Handheld.

PROGRAMMING

ATOMIC CONFIGURATION

The Handheld Controller is the interface between you and the Atomic EFI. Using it, you can go through the initial and advanced setups, monitor engine parameters in real time, and more. To power the Handheld for use, turn on ignition power (Key On). All basic functions for the Handheld are done through the joystick which allows for up, down, left, and right control as well as center pressing to input a change.

ATOMIC EFI DASH AND GAUGES

The Atomic Dash and Atomic Gauges do not have any adjustable features. They provide real time data of the Atomic and the engine such as rpm, air/fuel ratio, IAC counts, temperature and more.

INITIAL SETUP

Before starting the engine you will need to input a few engine parameters.

Engine Displacement: Select your engine size. Use the joystick to go up or down in 1 cubic inch or 0.1 liter increments.

Number of Cylinders: Select the number of cylinders. Use the joystick to go up or down with 1, 2, 4, 6, 8, or 12 cylinders. (Atomic EFI is not compatible with Odd-Fire V6 engines.)

Camshaft Selection: There are three selections; Street/Stock, Mild and Performance. Select the cam that best suits your application.

CAM	DURATION AT .050"
Stock	Less than 210°
Medium	211° - 230°
Large	Greater than 231°-250°

Note: If lobe separation angle (LSA) is less than 108° you may need to go to next larger cam profile. If cam duration is longer than 250° the Atomic will not be suitable for your application.

Fuel Pump Type: There are three selections for the fuel pump system. Select the system that you are using on your vehicle.

- **Pulse Width Modulated:** This selection is used only when running a returnless fuel system with NO regulator.
- **Non-PWM with Regulator:** This selection is used when running a return style system with a regulator.
- **PWM with Regulator:** This selection is used when running a return style system with a regulator. It will run the pump at 50% duty cycle at idle producing quieter pump operation and will increase a duty cycle of 100% as the throttle and injector load increase.

Note: It is recommended that you use Non-PWM with a regulator when setting fuel pressure as the PWM setting may decrease fuel pressure slightly at idle depending on the pump used.

Air Pump Equipped: If your engine is equipped with an OEM air pump, this value must be set to 'Yes'. This is covered in detail in the supplied addendum covering installation steps and settings for a CARB compliant installation.

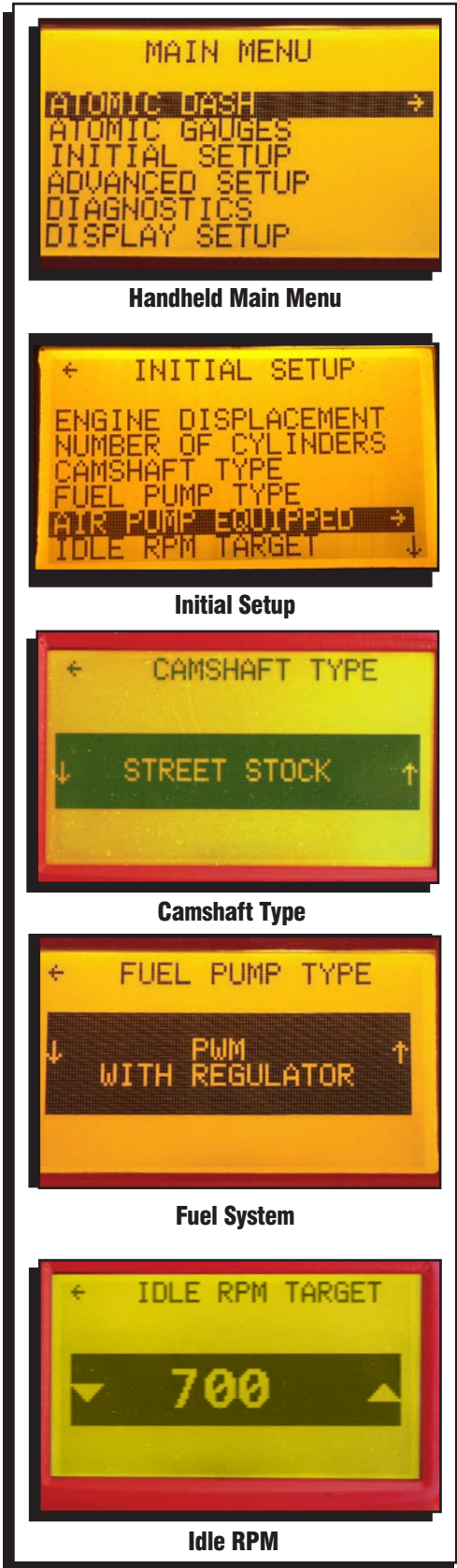

Figure 11 Initial Setup.

Idle RPM Target: This is the rpm that you want the engine to idle at while stopped and in gear. Adjustable in 25 rpm increments.

Timing Control: Choose between Enabled and Disabled. If Timing Control is Enabled, its features will be edited in the Advanced Setup. (Please see page 16 for more details on this option.) Note: It is recommended to start the engine initially without timing control.



Figure 12 Initial Setting

ADVANCED SETUP

Each of the settings in the Advanced Setup is optional. None of them are required to be edited at any time if they are not needed by your particular application. They are each designed to offer additional functionality to be used at your choice. For initial start, it is recommended to leave the default settings.

Fan Control - Use the Atomic to control two electric fan circuits. Each circuit can be turned on by selecting a start temperature using the joystick to go up or down in single degree increments. The fans will automatically shut off when the engine reaches 10° cooler than the start temperature. The two circuits can be used for independent fans or a single multispeed fan. A relay is required for each fan.

A/F Targets: The Atomic provides an option to set an air/fuel target for Idle, Part Throttle, Wide Open (WOT), Nitrous and Boost. The Atomic will use its self-learning technology to adjust the fuel delivery to meet the target air/fuel ratio. The values are adjusted in 0.1 increments and range from rich at 10:1 to leaner at 16:1. The ideal air/fuel ratio for cruising is called stoichiometric and is commonly referred as a 14.7:1 air/fuel ratio.

Boost: The Atomic will switch to the commanded Boost A/F ratio once manifold pressure reaches 110 KPa / 16 psia.

Nitrous: There is also a timing setting for a Wet Nitrous System. When a nitrous system is activated (by supplying 12 volts on the Violet Power Module wire), the Atomic will adjust its internal target A/F ratio to the commanded Air/Fuel ratio. Note that in order to set a Nitrous Air/Fuel target, and set a timing retard, the Nitrous Selection in the Advanced menu MUST be programmed to ENABLE.

Timing Control - The Atomic EFI system has the ability to control the engine's ignition timing, however, an MSD Ignition Control and adjustable rotor are required to use this feature. For initial startup, it is recommended to bypass the Atomic's timing control features. This will allow you to start the engine and tune the EFI to your engine. For more details and complete instructions for Timing Control, please see page 16 of these instructions.

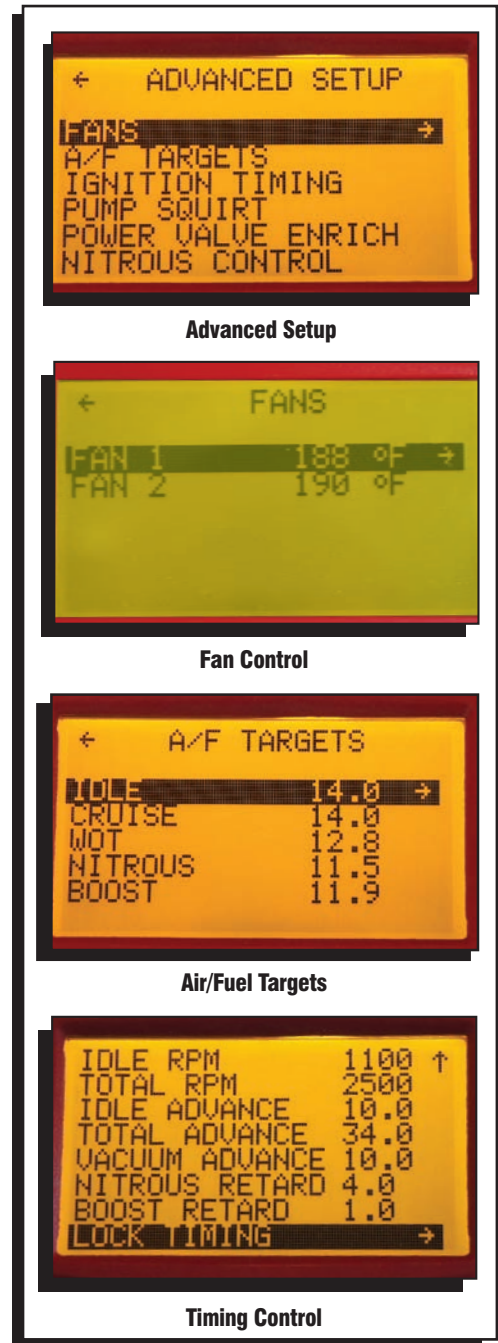

Figure 13 Advanced Setup.

Pump Squirt - To assist in throttle transitions the Atomic EFI has a feature to mimic the pump squirt of a carburetor. This works by increasing fuel delivery by a prescribed percentage any time there is an increase in throttle position. If needed, make small changes of no more than 5% increments without further testing. 25% is sufficient for most engines. Almost all vehicles will use between 15 and 35% pump squirt

Power Valve Enrich - To assist in manifold pressure transitions the Atomic EFI has a power valve feature. This works by adding fuel based on MAP transitions while moving the throttle. Large cam vehicles with low vacuum generally required a slightly smaller number while stock/small camshaft vehicles with a high vacuum may require more. If needed make small changes of no more than 5% increments without further testing, 25% is sufficient for most engines but between 15-35% is normal. Typically, the higher the vacuum (more stock) the higher the percentage needed.

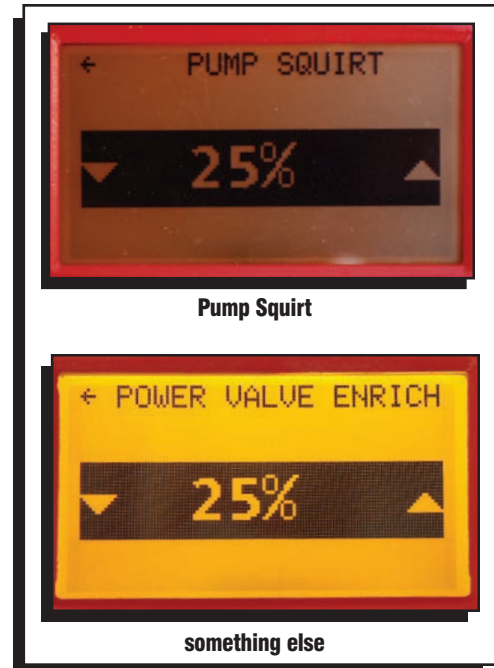

Figure 14

DISPLAY OPTIONS

Using the features in this section, users will be able to control the look of the Handheld unit. This section is also home to information regarding the Firmware and resets.

LCD Contrast - Adjust the contrast on the LCD screen if it is hard to see the display. Brightness is adjusted using the joystick to go up or down in five percentage increments.

Backlight Level - The brightness of the screen is determined by this setting. The Backlight Level may need to be adjusted depending on outside light levels. Brightness is adjusted using the joystick to go up or down in five percentage increments.

Display Units - The Atomic can display items in either English (cubic inches, Fahrenheit) or Metric (liters, Celsius).

Default Display - This selection provides the opportunity to select what screen you want the handheld to display at power on. The choices are Main, Dash or Gauges.

Backlight Timeout - This setting lets you control when the Handheld backlighting turns off. It can be set to Disable where it will always be illuminated, or it can be set to turn off from one second to 300 minutes after it is powered on.

Set Atomic Defaults - Use this feature to reset the Atomic EFI. Selecting "YES" on this screen will take all setting, including fuel maps, back to the factory defaults. Typically this will only be done when the Atomic is being installed on a different engine.

Firmware Versions - This is where information can be found on what is controlling the Atomic. If MSD releases an update, use this screen to determine which firmware is currently on the system to compare to the number of the release.

THROTTLE BLADE ADJUSTMENT

There is one more adjustment to review prior to starting the engine for the first time; the Throttle Blades. This is a setting that varies between engines to improve idle characteristics due to engine and cam size.

There are two adjustments that determine the position of the throttle blades, a front and rear (see Figure 15). Note that the front and rear throttles need to be opened the same amount to produce the best idle.

For initial start up, MSD recommends the following:

- On a street/stock type cam, turn the throttle screws $\frac{1}{2}$ turn from the point where the blades first start to move.
- For a mild cam, turn the screws one additional turn from the point where the blades first move.
- For Larger cams, turn the screw $1\frac{1}{2}$ turns from the point where the blades first move.

Once started, you will be able to monitor the IAC count (Idle Air Control) on the Handheld in the dash mode to improve or tune the idle. The IAC motor controls the amount of air flowing through the idle air circuit. It varies depending on the engine and operating conditions. When the engine is at operating temperature, let the engine come to an idle and monitor the IAC count. This count will range from 0 – 175 and at idle, a rule of thumb would be 10 - 20 with a manual transmission and 5-15 in gear with an automatic (less is ok, even 0).

If the count is too high, the IAC is trying to open too much and the blades should be opened to help with additional air flow at idle. Make any adjustments equally in front and rear using small steps such as a quarter turn at a time.

PRE-START CHECK LIST

At this point, you're ready to start the engine. Before attempting to start your vehicle with a newly installed Atomic EFI system, MSD recommends running through the following check list to help ensure a safe and successful start.

- Double-check all wiring.
- Power and Ground are run directly to the battery.
- The small Red "12V switched" wire from the Power Module will have power during both Key On and Cranking.
- The Power Module, fuel pump, fuel lines, and wires are securely mounted away from heat sources and pinch points.
- Wide Band Oxygen Sensor is installed in a proper location.
- There are **No** known exhaust leaks.
- Throttle linkage is complete and operational from the pedal.
- Handheld receives power during Key On.
- You have completed each step of the Initial Setup in the Handheld.
- At Key On the fuel pump primes.
- There are **No** fuel leaks when system is under pressure.
- Check for proper fuel pressure on Handheld Dash. If you do not see fuel pressure, you may need to prime the pump more than once.
- When ready to start engine, watch for Engine RPM on Handheld Dash to know that Atomic is getting proper input.
- Timing feature is disabled (unless using timing feature).
- Be prepared to adjust the throttle blades as shown above.

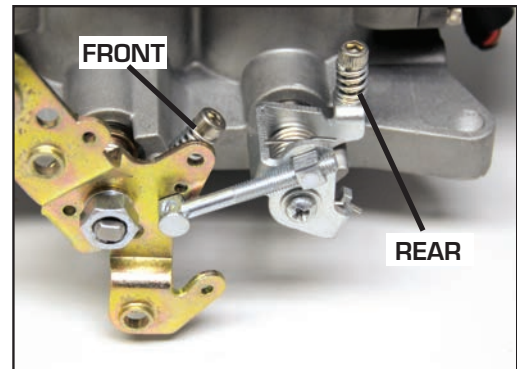

Figure 15 Throttle Blade Adjustment.

START YOUR ATOMIC FUELED ENGINE!

ATOMIC EFI TIMING CONTROL

The Atomic EFI has the ability to control the engines ignition timing. This is an optional feature and is NOT required for proper functioning of the fuel injection. By implementing ignition timing control through the Atomic EFI, the engine will have more precise control and an improved idle. It is important to note that most rough or inconsistent idle issues can be resolved through proper throttle blade adjustment as outlined on page 15.

MSD recommends that those who wish to use the Atomic's timing control feature first get the engine to run without timing control. Splitting the timing control into a secondary process will add very little time to the total install, but could significantly help with trouble shooting, should it be needed.

The following are a list of items that are required to use the timing features of the Atomic system:

- An MSD Ignition control such as a 6A or 6AL Ignition
- The distributor must be locked-out
- An adjustable rotor is required to achieve accurate rotor phasing. For standard GM size MSD distributors, use rotor PN 84211. For larger, Ford style MSD distributors it is recommended to fit the distributor with a smaller cap (PN 8433) and the PN 84211 rotor. If the larger cap must be used, try rotor PN 8421.
- It is recommended but not required to use an MSD Pro Billet Distributor with a 2-pin mag pickup connector.
- The balancer must be degreed, or use MSD Timing Tape, PN 8985
- A timing light will be required.

PREPARATION FOR ATOMIC TIMING

See page 17 for wiring information.

Before removing the distributor, bring the number one cylinder to approximately 15° BTDC on the compression stroke.

1. Remove the distributor cap and note the position of the rotor. You will be removing the distributor to lock it out, this will be your reference position for the number one cylinder.
2. Remove the distributor clamp and pull the distributor out of the engine.
3. If you are using an MSD Distributor (recommended), follow the steps below to lock-out the mechanical timing.
 - a. Remove the advance components including the springs, weights and the advance stop bushing from the advance assembly.
 - b. Remove the roll-pin from the drive gear and remove the gear from the housing shaft (except on Fords).
 - c. Slide the shaft two inches out of the housing.
 - d. Rotate the shaft 180° and insert the advance stop bushing pin into the small hole on the advance plate (Figure 16).
 - e. Install the locknut and washer to the advance stop bushing pin. This locks the advance in place.
 - f. Put the shaft back in the housing
 - g. Install the drive gear and roll-pin.
4. Some applications will require the vacuum advance be removed. Please see page 16 for details, or Appendix A for a complete list of distributors. If your vacuum advance needs removed and locked out, use the following steps.
 - a. Remove the two Allen head screws that hold the advance canister (Figure 16).

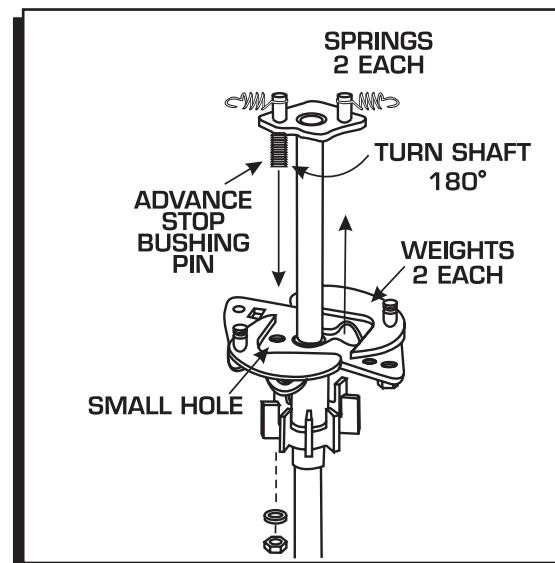

Figure 16 Locking Out the Advance.

- b. Remove the snap ring that holds the magnetic pickup assembly in place.
- c. Gently lift up on the mag pickup plate and slide the vacuum canister out.
- d. Install the Lockout Plate in place of the canister. Install the two retaining screws.
- e. Install the supplied screw and washer through the Lockout and tighten.
- f. It is important to make sure the pickup plate is parallel with the housing of the distributor (Figure 16). If it is cocked or slanted, the paddles of the reluctor may contact the pickup.
- g. Check the clearance by rotating the distributor shaft. If necessary, use the supplied shims under the Lockout hold-down to correctly position the pickup plate.

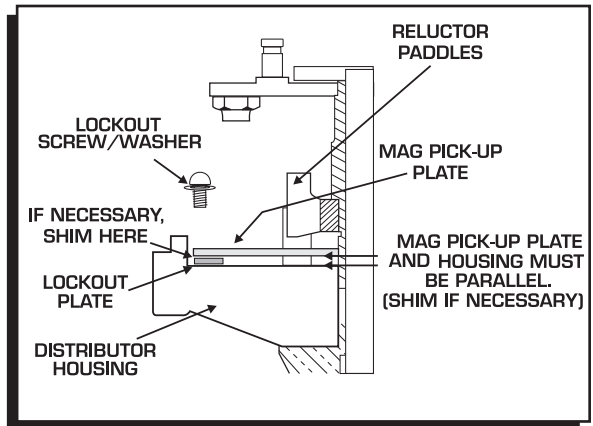

Figure 17 Checking Installation of the Lockout Plate.

Note: If no shims were required, use one beneath the washer of the Lock-Out Hold Down Screw.

INSTALL THE ADJUSTABLE ROTOR

1. Install the new adjustable rotor (MSD PN 84211 or PN 8421).
2. Set the phasing of the adjustable rotor based on the information in the MSD Ignition Control Manual.

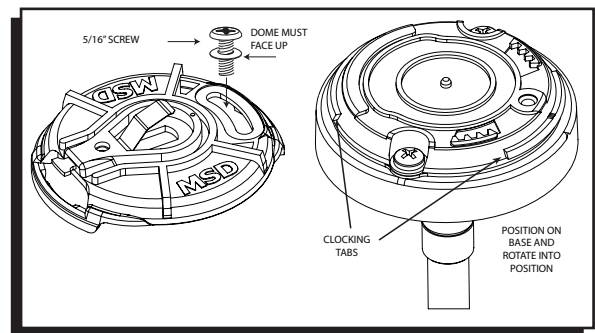

Figure 18 Two Piece Rotor, PN 84211.

ROTOR PHASING

To phase your rotor properly for the Atomic EFI to control ignition timing, set it retarded (opposite rotation) at 15° on the rotor indicator. Remove and lockout the vacuum advance, if applicable, on all distributors except Fords*.

* Distributor PN 8573 will need the vacuum canister removed and locked out. Distributors PN 8386 and 8387 keep the vacuum canister in place.

Please see Appendix A for a complete list of our distributors, the required adjustable rotor, and other applicable notes.

INSTALL THE DISTRIBUTOR

1. Position the engine at 15° Before Top Dead Center (BTDC).
2. Install the distributor making sure the rotor comes to rest pointing at the number one terminal of the distributor cap.
3. Tighten the distributor clamp – but leave it so the distributor can be moved.
4. Connect the distributor’s magnetic pickup to the matching connector on the throttle body.
5. Connect the Yellow wire of the Atomic to the White input wire on the MSD Ignition Control. This is the trigger signal for the ignition.
6. Install the cap and spark plug wires.

Idle RPM - Set this to the rpm at which you would like the Atomic to start advancing ignition timing off idle.

Total RPM - This is the rpm at which the Atomic should have full ignition timing.

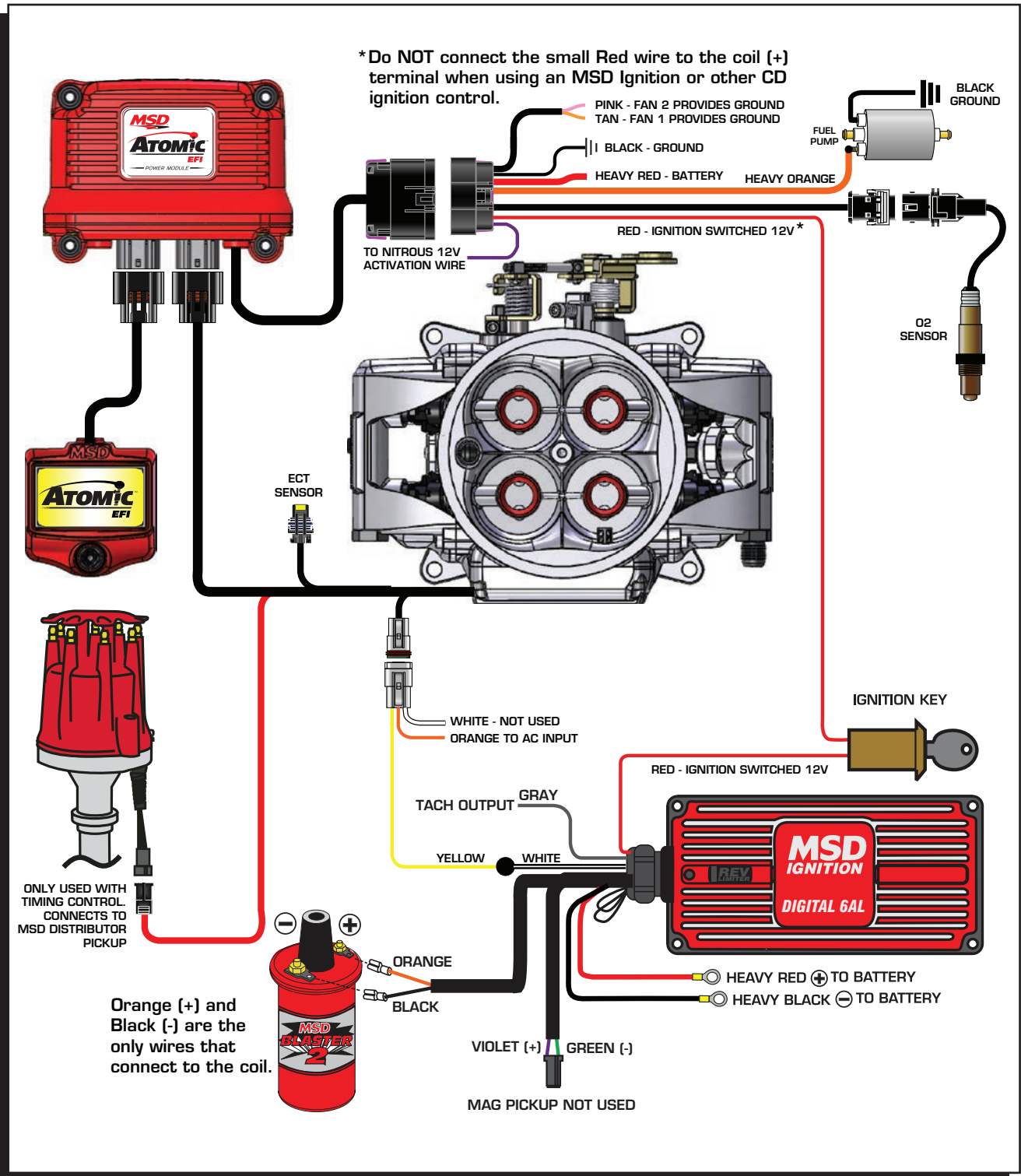

Figure 19 Atomic Wiring to use Timing Control.

SETTING THE ATOMIC TIMING

Connect the Handheld Control and select Ignition Timing from the Advanced Menu.

Idle Advance - This is the initial ignition timing from which timing will advance as the engine climbs in rpm.

Total Advance - This is the total advance in ignition timing the engine should receive based on rpm.

Note: Total timing must always be a higher number than the idle timing setting.

Vacuum Advance - The Atomic can add ignition advance based on manifold vacuum using the built in MAP sensor. Use the joystick up or down to set amount of timing advance in single degree increments.

Nitrous: When a nitrous system is activated (by supplying 12 volts on the Violet Power Module wire), the Atomic will retard the timing up to 20°. Note that in order to alter the timing for nitrous use, the Nitrous Selection in the Advanced menu MUST be programmed to ENABLE.

Lock Timing - When this section is selected the ignition timing will be locked at 15° BTDC by the computer so that the engine's idle timing can be checked with a timing light. If this screen is not active the idle timing is controlled by the Atomic ECU and will be continually adjusted.

Boost: On boosted applications, you can set a timing retard based on boost pressure. Adjustable in 0.1° per pound of boost.

Note: The Atomic has a feature that will retard the timing when coolant temp and intake air temp reach a certain point. This is designed to protect the engine from high heat detonation.

Note: Timing cannot be retarded past 5°.

INITIAL START UP AND SETTING THE TIMING

Before starting the engine, have a timing light handy as the first step will be positioning the distributor.

1. Turn the key On to power the system and go to Advanced Setup to Ignition Timing and select Lock Timing. This screen allows you to set the distributor exactly where the Atomic ECU needs it to be positioned to operate the timing.
2. Start the engine and using the timing light, move the distributor to 15° BTDC. Tighten the hold down clamp.
3. Leave the Lock Timing screen. This will take you back to the Ignition Timing screen and the Atomic will now be controlling the ignition timing. It is important to note that you will not see accurate timing at idle speed when viewing with a timing light. This is due to ECU calculations. If you rev the engine off idle, the timing will appear correctly.
4. Once back to the Ignition Timing Screen, you can adjust the total and idle timing as well as the rpm points that control the rate of the advance.
5. There is also a vacuum advance option on the handheld. Vacuum advance is generally a feature that assists in economy. The Atomic allows you to select a total amount of vacuum advance. This will take some time to tune to depending on your application. Note that the vacuum advance reads off ported vacuum so it will not come in until the throttle is open.



Figure 20 Timing Settings.

DIAGNOSTICS

There is a self-diagnosing system built into the Atomic EFI. Each covered parameter can show a status in one of three ways.

“OK”: the parameter is functioning normally.

“Error C”: there is currently an error occurring.

“Error H”: there was previously an error that has been remediated within the last ten ignition cycles.

The following chart gives the most likely solution(s) to each possible error.

CLEARING HISTORY ERRORS

There are two ways to clear an error. First, the code will erase after 10 key cycles. Second, is to simply navigate to the message screen and push the joystick down to clear the codes.

CODE NAME	WHAT IT MEANS	PROBABLE CORRECTION(S)
TPS	There is no reading for the Throttle Position Sensor.	The sensor may be at fault. Note that the TPS is integral of the throttle body.
MAP	There is no reading for the Manifold Air Pressure Sensor.	The sensor maybe at fault. Note that the MAP sensor is integral of the throttle body.
IAT	There is no reading for the Inlet Air Temperature Sensor. The ECU will default to 275° when open.	The sensor may be at fault. Note that the IAT sensor is integral of the throttle body.
ECT	There is no reading for the Engine Coolant Temperature Sensor. The ECU will default to 275° when open.	Check to see that the sensor is properly installed and plugged in. If the sensor is connected but there is no signal, it will need to be replaced.
BATT	The Atomic is receiving the wrong voltage. The unit is measuring either less than 9 volts or greater than 16 volts.	Check that the Atomic has power and ground directly from the battery. Also be sure the vehicle's battery and charging system are in proper working order.
INJ DC	Excessive Injector Duty Cycle	If you are running a returnless fuel system your engine's needs may exceed the Atomic's maximum capabilities. If you are running a return system check to see that you are maintaining the recommended fuel pressure. If you have adequate fuel pressure the engine needs may exceed the Atomic's system capabilities.
FUEL PRESSURE	There is no reading for the Fuel Pressure Sensor.	The sensor will need to be replaced.
WBO2	A. "NOT CONNECTED" indicates that no sensor is detected. B. "ERROR" indicates that the sensor has failed.	A. Check to see that the sensor is securely plugged into the system. B. The sensor will need to be replaced.
FP CAV	This code will set if there is an issue with Fuel Pump Cavitation (similar to vapor lock). It can only set when running a returnless fuel system. This may occur when the commanded fuel pressure (from the ECU) is different than the fuel pressure (at the sending unit).	This means you need to review your fuel pump system and confirm that your application meets the requirements to run a returnless (PWM) system. Also check the filters, the sock in the tank and inspect the lines for any kinks or pinches that would affect the fuel flow and pressure of the system. If everything checks okay and the code continues, you may need to move to an in-tank pump, or use a regulated (return) fuel system.

CLEAR FLOOD

If a flood condition occurs, turn the key on then press the accelerator to wide-open throttle. This tells the ECU to turn off the injectors. Crank the engine to clear the flood condition until the engine starts (release the throttle open start-up).

Note: The TPS is self calibrating so the key must be in the On position prior to pressing the accelerator.

MSD Atomic EFI Trouble Shooting

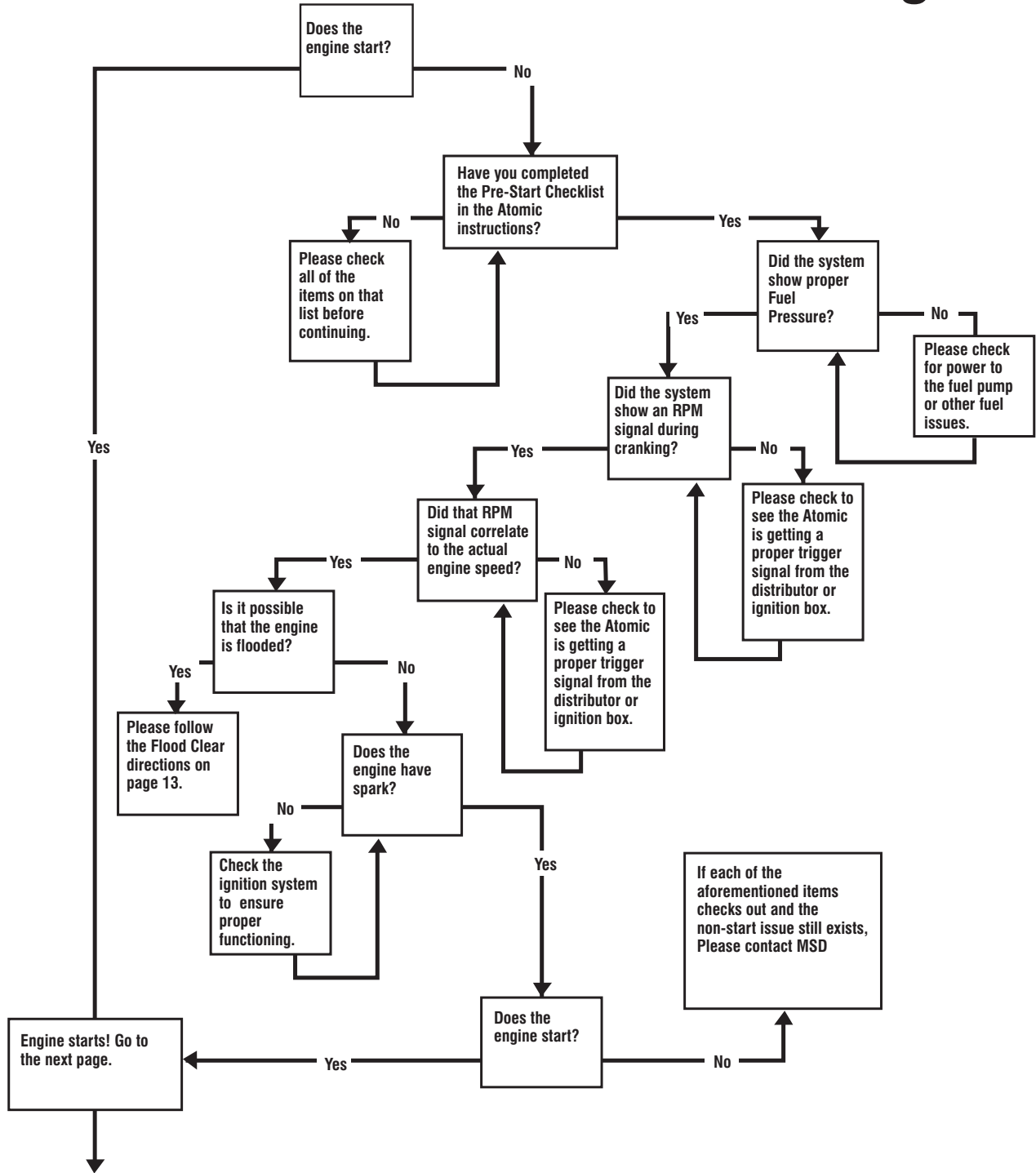

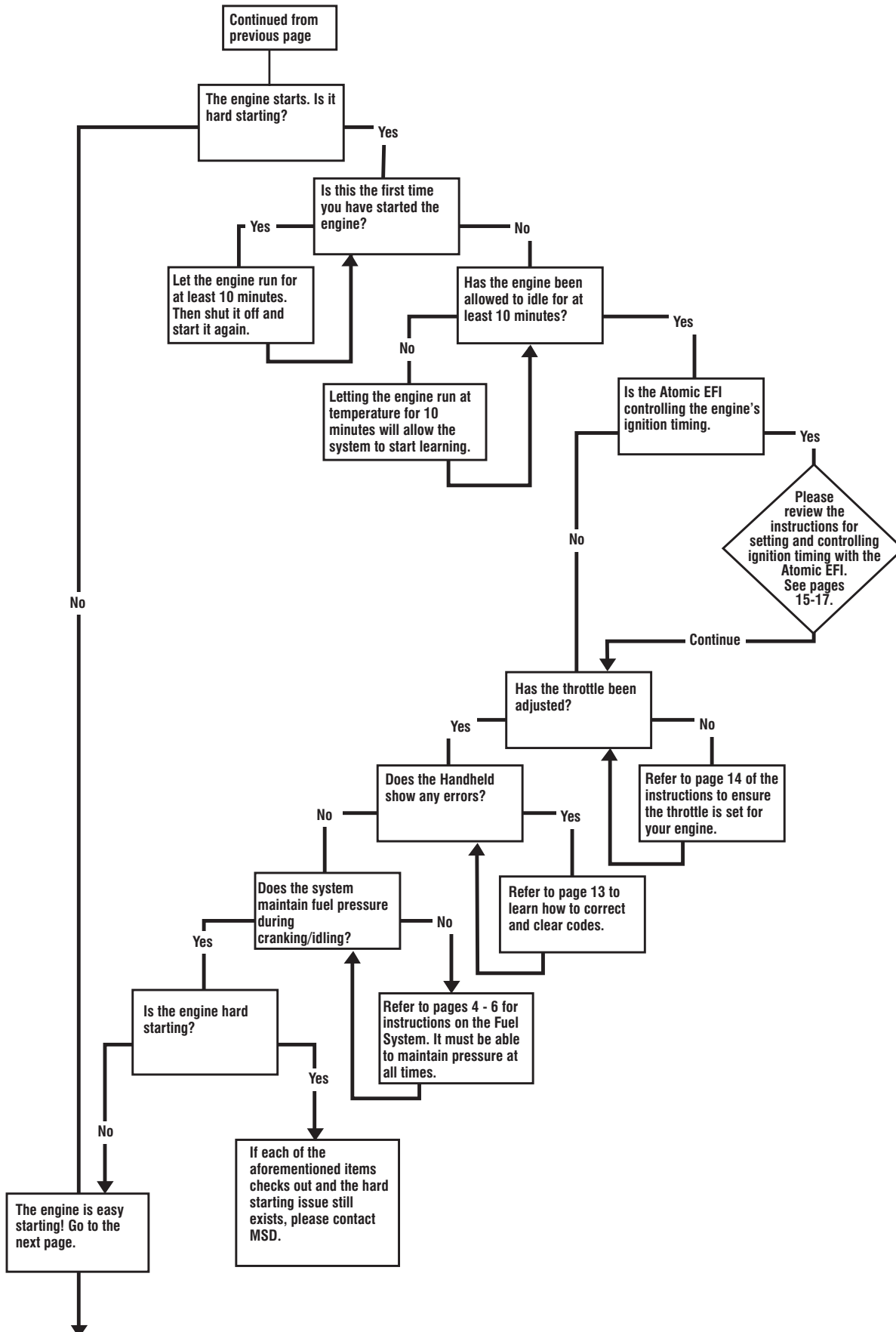

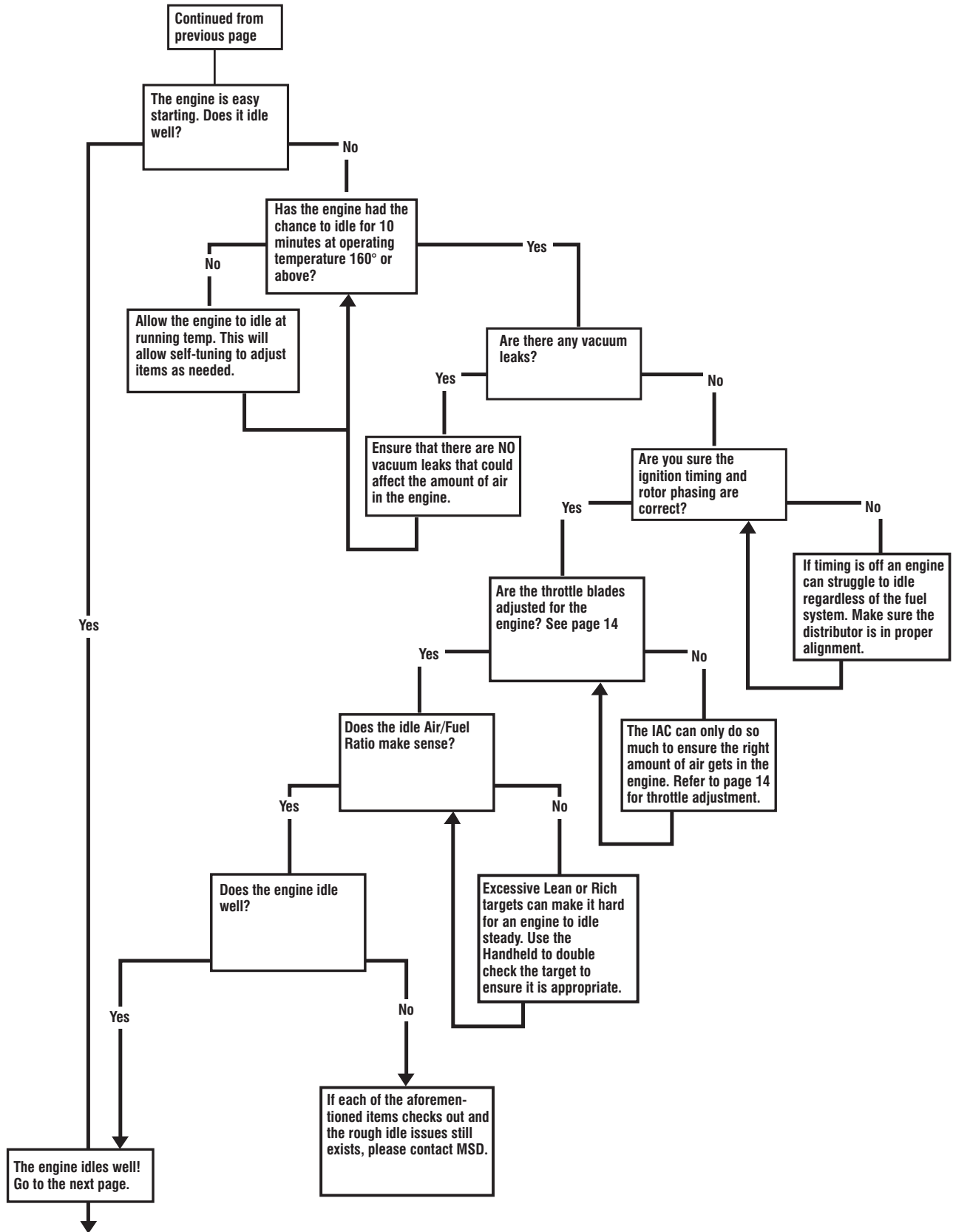

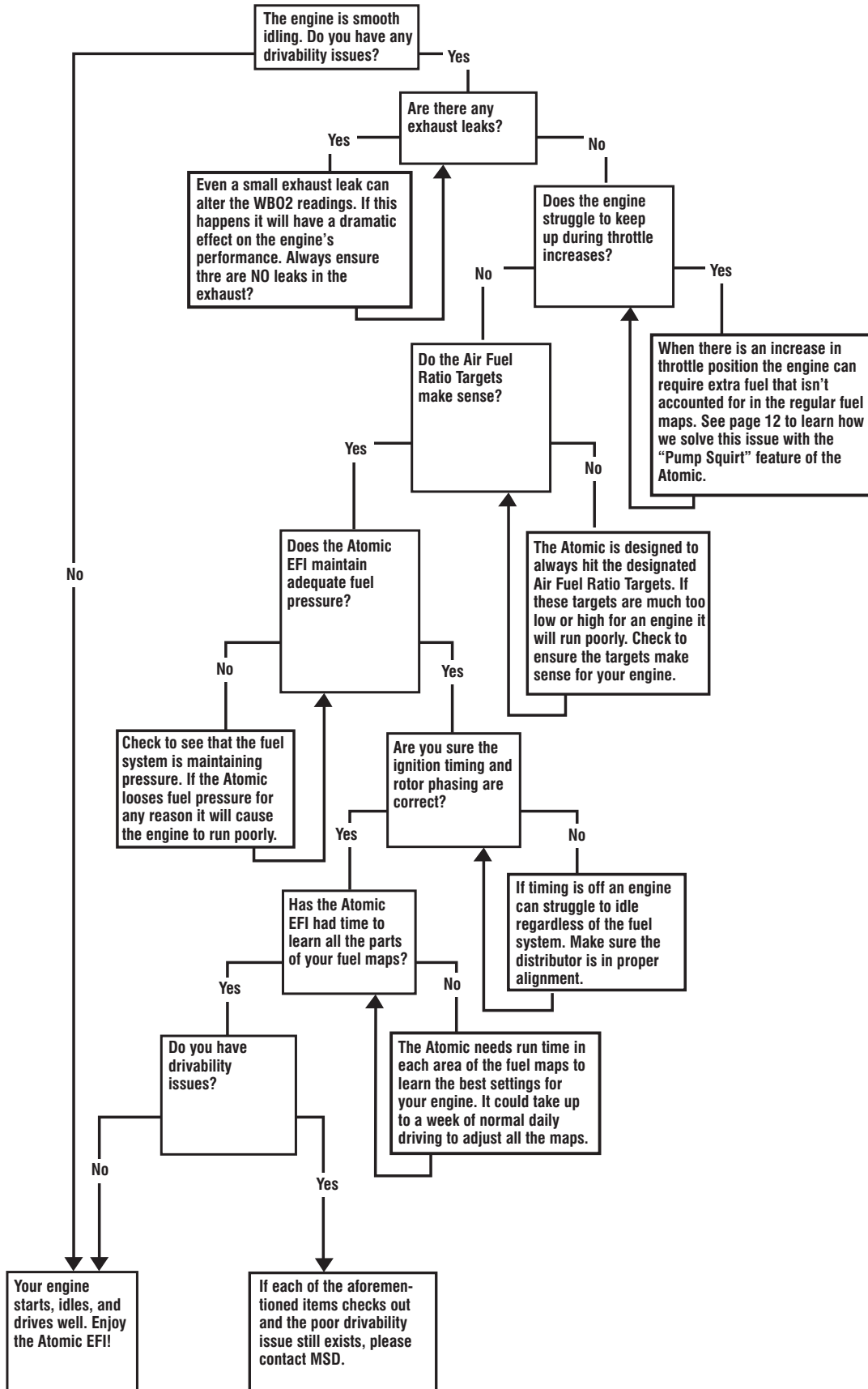

APPENDIX A - ATOMIC IGNITION TIMING CONTROL: ROTOR PHASING DETAILS

DIST	APPLICATION	DISCRIPTION	ROTOR NEEDED	ROTOR RETARD NEEDED	NOTES
83506	FORD	R-t-R Marine Ford 351-460	84211	15°	
8517	BUICK	Buick V8 Billet, 400-455	84211	15°	
8548	BUICK	Buick V8 215-350 Pro Billet	84211	15°	
8547	CHEVY	Super Tall Block, Mag Pick.	8421	15°	
8355	CHEVY	OBS-Dist,Chevy, D/ PU, Locked*Sub w/8356	84211	15°	
8356	CHEVY	Chevy V8, Dual Pickup	84211	15°	
85501	CHEVY	Chevy V8,Pro-Billet,locked,cap,rotor	84211	15°	
85503	CHEVY	Chevy V8, w/Capadapt/ locked Shaf	84211	15°	
85551	CHEVY	Chevy V8,Pro-Billet,w/Cap, Rotor	84211	15°	
85553	CHEVY	Chevy V8, Mod Shafiroff	84211	15°	
85561	CHEVY	Chevy V8 w/Slip Collar,Cap, Rotor	84211	15°	
83606	CHEVY	R-t-R Marine Chevy V8	84211	15°	
8534	CHRY	Chrysler, 318, 360	84211	15°	
8582	FORD	Ford V8, 302	8421	15°	
8598	FORD	Ford 289/302 Hyd Roller-Steel Gear	8421	15°	
8580	FORD	Ford V8, 351C, 460	8421	15°	
85805	FORD	Ford 351W, w/ Edel. Vic. Jr	8421	15°	
8584	FORD	Ford V8, 351W	8421	15°	
85840	FORD	Ford 351W,w Roller Stl Gear	8421	15°	
8569	FORD	Ford 351C/M, 460, L.P., CT	84211	15°	
8498	GM	OBS-GM Ecotec 4 cylinder	8421	15°	
8589	HOLDEN	Holden V8 308 ci engines	84211	15°	
8566	OLDS	Oldsmobile V8, 350, 455	84211	15°	
8490	PONT	OBS-151 4Cyl	8421	15°	
8563	PONT	Pontiac V8, 350, 455	84211	15°	
2345	CHEVY	Ign. Trigger Sync Signal Lock/Out	84211	15°	
23451	CHEVY	Ign Trig. w/Hall LED Sync Pickup	84211	15°	
23451EDEL	CHEVY	Ign Trg w/LED Sync Pckup & LD Cap	84211	15°	
2357	CHEVY	Cam Sync w/Rotor Phasing, Chevy V8	84211	15°	
8570	CHEVY	Chevy V8,Small Cap/Base	84211	15°	
8545	CHRY	Chrysler 383,400 Pro-Billet	84211	15°	
8546	CHRY	Chrysler 426,440	84211	15°	
2358	FORD	Sync Rotor Phas, 289/302 Steel Ger	84211	15°	
2358EDEL	FORD	Cam Sync Ford 289/302, Steel Gear	84211	15°	
2358ROUSH	FORD	Sync Rotor Phasing, 289/302, Roush	84211	15°	
2359	FORD	Sync Rotor Phas, 289/302, Cast Ger	84211	15°	
2360	FORD	Sync Rotor Phas, 289/302 Bronze Gr	84211	15°	
8579	FORD	Ford 302, Pro Billet, Small Cap	84211	15°	
2362	FORD	Sync Rotor Phas, 351W, Steel Gear	84211	15°	
2362EDEL	FORD	Cam Sync Ford 351W, Steel Gear	84211	15°	
2362ROUSH	FORD	Sync Rotor Phasing, 351W, Roush	84211	15°	
2363	FORD	Sync Rotor Phasing, Ford FE, Roush	84211	15°	
2363ROUSH	FORD	Sync Rotor Phasing, Ford FE, Roush	84211	15°	
8577	FORD	Ford 351C-460, ProBillet, Small Cap	84211	15°	
8578	FORD	Ford 351W, Pro Billet, Small Cap	84211	15°	
2356EDEL	PONT	Pontiac Cam Sync w/Hall Effect P/U	84211	15°	
8394	CHEVY	GM Digital E-Curve	84211	15°	
8504	CHRY	Chry 318, 340, 360, E-Curve	84211	15°	
8503	FORD	Ford 289/302, E-Curve	84211	15°	
8477	FORD	Ford 351C-460, Vac. Advance	84211	15°	Keep Vacuum Canister in place.
8478	FORD	Ford 351W, Vacuum Advance	84211	15°	Keep Vacuum Canister in place.
8478ROUSH	FORD	Roush Ford 351W, Vacuum Advance	84211	15°	Keep Vacuum Canister in place.
8479	FORD	Ford 289/302, VacuumAdvance	84211	15°	Keep Vacuum Canister in place.
8386	CHRY	Chry. 383-400, R-t-R	84211	15°	Keep Vacuum Canister in place.
8387	CHRY	Chry. 440,426 R-t-R	84211	15°	Keep Vacuum Canister in place.
8350	FORD	Ford 351C-460, R-t-R	84211	15°	Keep Vacuum Canister in place.
83501	FORD	Ford 351C-460, R-t-R,Stl Gr	84211	15°	Keep Vacuum Canister in place.
8352	FORD	Ford 289/302, R-t-R	84211	15°	Keep Vacuum Canister in place.
83521	FORD	Ford 289/302, R-t-R, Stl Gr	84211	15°	Keep Vacuum Canister in place.

DIST	APPLICATION	DISCRIPTION	ROTOR NEEDED	ROTOR RETARD NEEDED	NOTES
8352EDEL	FORD	Ford 289/302, R-t-R, EDEL	84211	15°	Keep Vacuum Canister in place.
8354	FORD	Ford 351W, R-t-R	84211	15°	Keep Vacuum Canister in place.
83541	FORD	Ford 351W, R-t-R, Steel Ger	84211	15°	Keep Vacuum Canister in place.
8383	FORD	R-t-R, Ford Y Block	84211	15°	Keep Vacuum Canister in place.
8595	FORD	R-t-R, Ford FE	84211	15°	Keep Vacuum Canister in place.
8523	AMC	R-t-R, AMC V8	84211	15°	Remove Vacuum Canister and lockout advance.
8519	AMC	AMC V8 Engines	84211	15°	Remove Vacuum Canister and lockout advance.
8524	BUICK	R-t-R Buick Nailhead	84211	15°	Remove Vacuum Canister and lockout advance.
8552	BUICK	R-t-R, Buick 455 V8	84211	15°	Remove Vacuum Canister and lockout advance.
8360	CHEVY	Chevy V8 w/Internal Module	84211	15°	Remove Vacuum Canister and lockout advance.
83602	CHEVY	Chevy w/Int Module, wo/Vac Advance	84211	15°	Remove Vacuum Canister and lockout advance.
8360EDEL	CHEVY	Chevy V8, R-t-R, Edelbrock Crate	84211	15°	Remove Vacuum Canister and lockout advance.
8393	CHEVY	Chevy 348/409 R-t-R	84211	15°	Remove Vacuum Canister and lockout advance.
8361	CHEVY	Chevy V8, Billet w/Vacuum Adv.	84211	15°	Remove Vacuum Canister and lockout advance.
8363	CHEVY	Cadillac V8 w/Vacuum Advance	84211	15°	Remove Vacuum Canister and lockout advance.
8388	CHRY	Chry. 440,426 R-t-R	84211	15°	Remove Vacuum Canister and lockout advance.
8389	CHRY	R-t-R, Chry	84211	15°	Remove Vacuum Canister and lockout advance.
8391	CHRY	R-t-R, Chrysler 331	84211	15°	Remove Vacuum Canister and lockout advance.
8573	FORD	Flathead Ford, R-t-R, 49-53	84211	15°	Remove Vacuum Canister and lockout advance.
85891	HOLDEN	Holden R-t-R V8 308	84211	15°	Remove Vacuum Canister and lockout advance.