

# MSD INSTALLATION INSTRUCTIONS

## Universal Ignition Tester PN 89981

**ONLINE PRODUCT REGISTRATION:** Register your MSD product online. Registering your product will help if there is ever a warranty issue with your product and helps the MSD R&D team create new products that you ask for!

### Parts Included:

1 - Digital Ignition Tester, PN 89981

1 - Test Plug

1 - Power Grid Adapter Harness

### FEATURES

- Large and easy to read display
- 9 different crank types
- Points and Magnetic signal
- Cam Sync output
- Test mode RPM scan
- Battery readout
- Dwell/Duty-Cycle control

### DIAL RPM SELECTION

The RPM dial can be pressed to select between 'Fine', 'Coarse' & 'Auto' to help find your target RPM

### KNOB FUNCTIONALITY

Turn the knob clockwise to move upward through menu items or increment values; turn the knob counter-clockwise to move downward through menu items or decrement values.

Quickly press and release the knob to confirm a selection, or press down for 2 seconds to access menus.

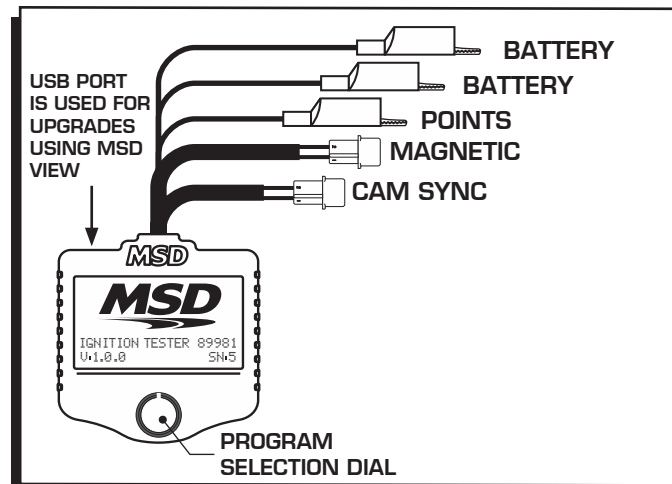

Figure 1 PN 89981 Universal Ignition Tester

WIRING		
RED	POWER	CONNECT TO 12V OR BATTERY (+)
BLACK	GROUND	CONNECT TO GROUND OR BATTERY (-)
WHITE	POINTS	FOR TESTING POINTS (WHITE WIRE) INPUT OF AN MSD IGNITION, SHIFT LIGHTS, TACHOMETERS & RPM SWITCHES
GREEN	MAG -	FOR TESTING THE MAGNETIC INPUT CIRCUIT OF MSD IGNITIONS. PLUGS DIRECTLY INTO THE MSD MAGNETIC PICKUP CONNECTOR,
VIOLET	MAG +	
BLUE	CAM +	FOR TESTING THE CAM SYNC PICKUP CIRCUIT OF AN MSD PROGRAMMABLE IGNITION OR CPC IGNITION SYSTEM PICKUP CONNECTOR.
GREEN	CAM -	
POWER GRID ADAPTER		
GREEN	MAG -	ADAPTS TO THE POWER GRID 3 PIN MAGNETIC PICKUP PIGTAIL. SEE FIGURE 2.
VIOLET	MAG +	

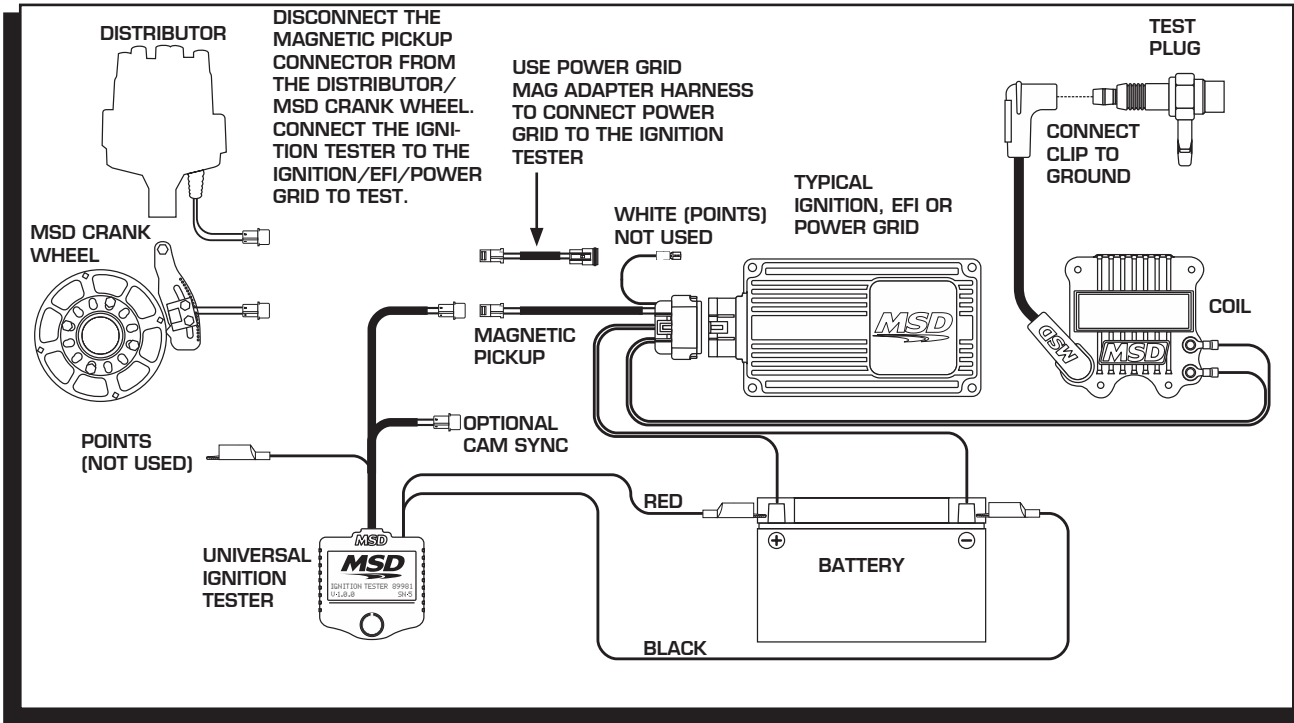

Figure 2 Ignition Testing Via the Mag Pickup

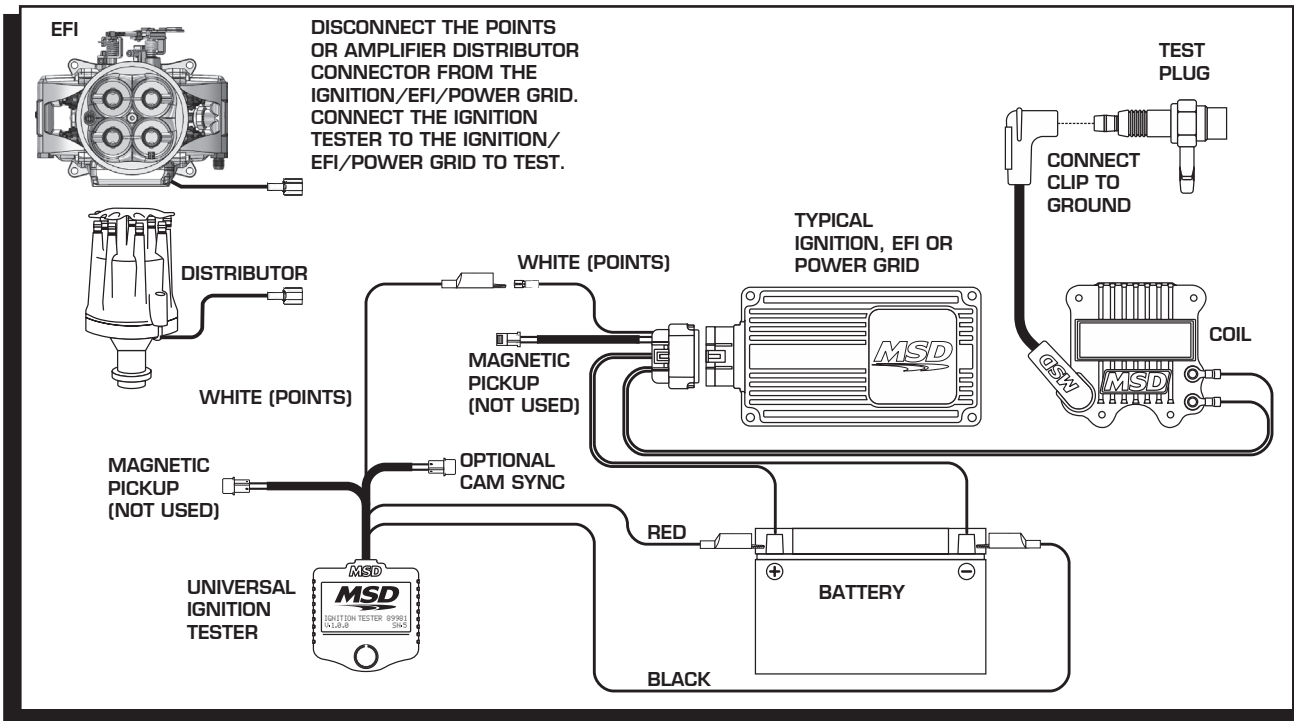

Figure 3 Ignition Testing Via Points (White Wire)

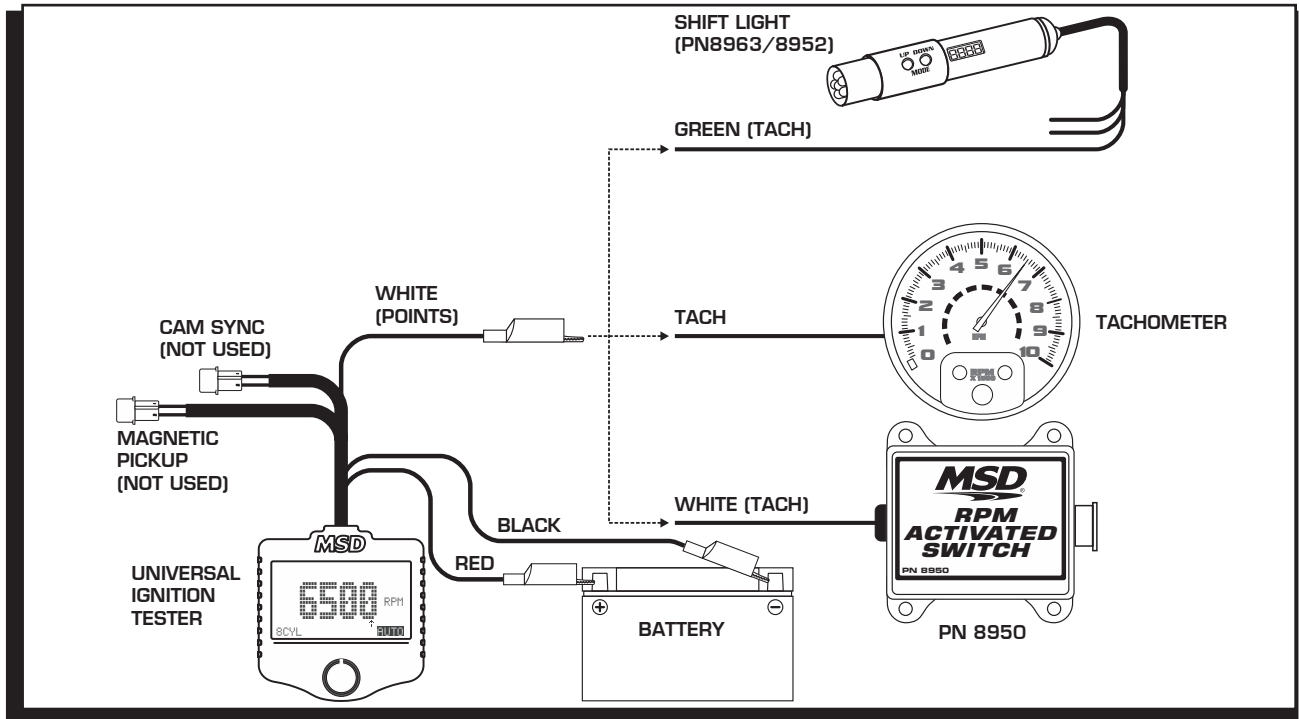

Figure 4 Ignition Testing Via Points (White Wire)

**SETTINGS MENU**

Adjustable settings, such as the crank type, duty cycle and Run Mode, can be calibrated for the desired application. The display features can also be fine tuned for individual preferences. To access the menu screen, press the knob for 2 seconds.

Crank Type:

Select desired crank type – 8CYL, 6CYL, 6-ODD, 4CYL, 12CYL, 1X, 24X, 58X, 12-1, or 35X. (Default 8CYL)

Duty Cycle (Points Output Only):

Select from 10 to 60 Degrees. (Default: 20)

**Settings:**

Display: Adjust Contrast or Brightness

Factory Defaults: Displays factory defaults with the option to reset current settings.

Save Current Settings: Select to Save current settings in device.

**Run Mode:**

Settings:

- Speed A: 0 - 20000 RPM (1 RPM increments)
- Speed B: 0 - 20000 RPM (1 RPM increments)
- Speed Hold A: 0.0 -10.0 in seconds (0.1 second increments)
- Speed Hold B: 0.0 -10.0 in seconds (0.1 second increments)
- Ramp A to B: 0.0 -10.0 in seconds (0.1 second increments)
- Ramp B to A: 0.0 -10.0 in seconds (0.1 second increments)

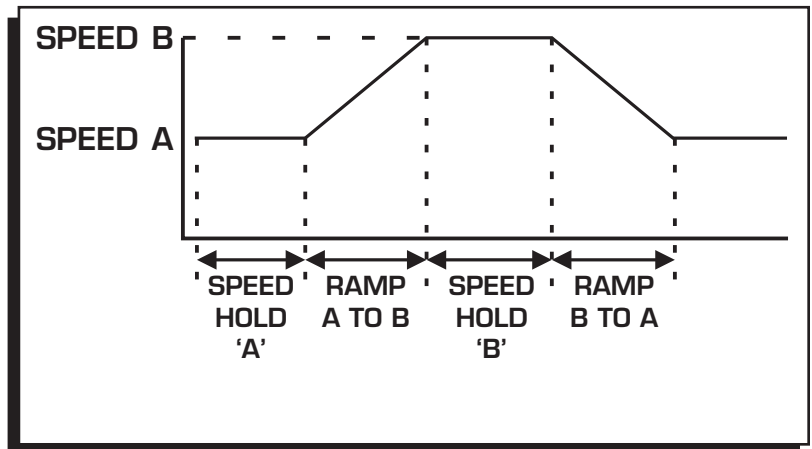

Figure 5 Test Run Mode

Speed A:	2000 RPM
Speed B:	5000 RPM
Speed Hold A:	5.0 sec
Speed Hold B:	7.0 sec
Ramp A to B:	3.0 sec
Ramp B to A:	6.0 sec

Figure 6 Run Mode Settings Example

# **INSTALLATION INSTRUCTIONS**

---

For the example shown in Figure 6, the starting point of 2000 RPM (Speed A) will hold for 5 seconds (Speed Hold A), and then ramp up to 5000 RPM (Speed B) over 3 seconds (Ramp A to B) - where it will then hold for 7 seconds (Speed Hold B). After the 7 second hold, the 5000 RPM will ramp down to 2000 RPM in 6 seconds (Ramp B to A) and will repeat the run. The test run will repeat until the selection dial is pressed to end the run.

Run - Current: Starts generating the output that corresponds to the current Run Mode settings.

Run - Always: This option sets the run to restart after a power down.

## **Diagnostic:**

Battery: Displays battery voltage.

## **USB Port:**

The USB port is used for installing software upgrades via the MSD View Software.