

INSTALLATION INSTRUCTIONS

MSD LS Coil Harness PN 88867

Parts Included:

1 - Harness
1 - Fuse Holder

Parts Bag:

1 - 20a Fuse
1 - Butt Connector

1 - Ring-lug

This harness has been made by MSD to correct a check engine light issue that can arise in vehicles using the MSD LS Coil Packs on their engines. This harness will supply additional battery voltage to the coils in order to fire the coils properly and not drain other engine systems of power. This is necessary do to the varying wire gauges used on production vehicles.

INSTALLATION

1. Locate the OEM harness that connects to the coil harnesses on each side of the top of the engine,
2. Unplug the coil harnesses from the OEM harness,
3. Use the new MSD harness to plug in and bridge between the OEM and coil harnesses,
4. Securely mount the attached relay,
5. Connect the included Orange wire to the positive battery terminal, and
6. Insert the included 20amp fuse into the box on the Orange wire.

Note: Be sure to always avoid heat sources, sharp objects, and sources of corrosives while routing any wires.

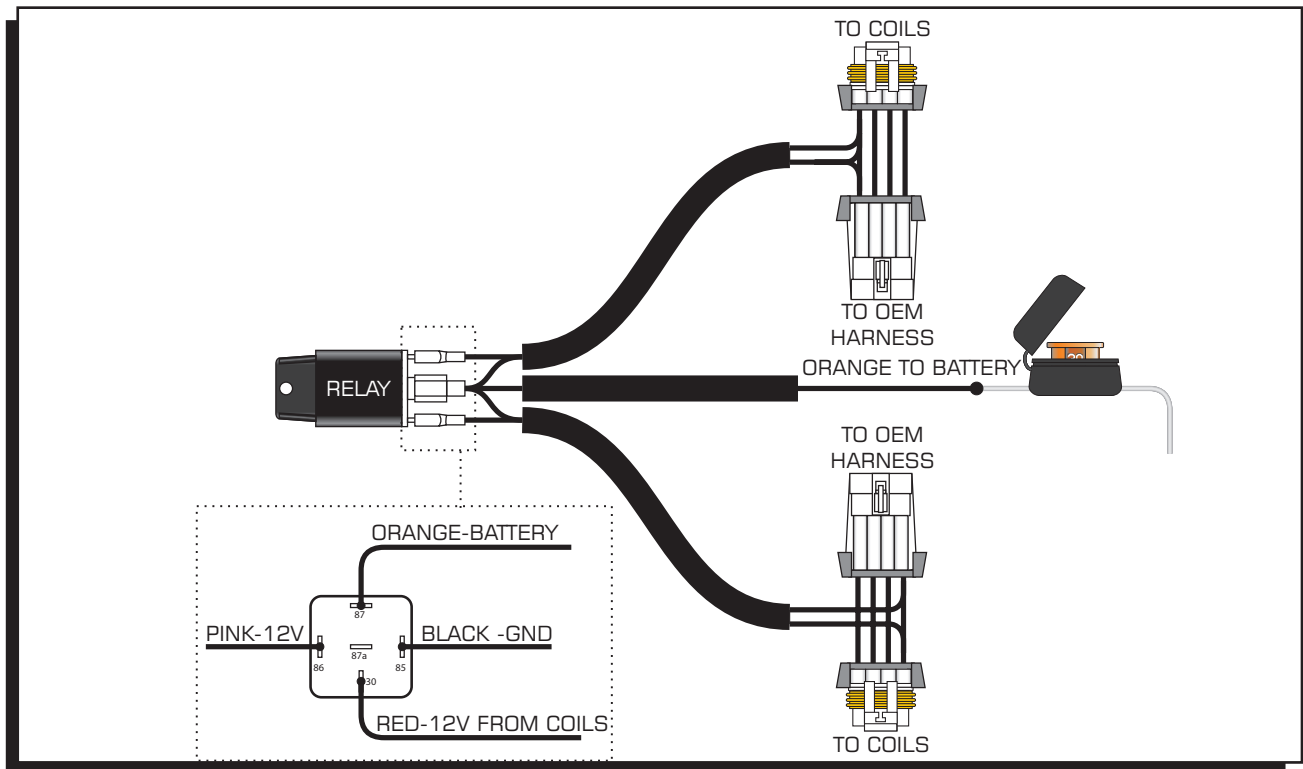

Figure 1 Wiring.