

MSD[®] IGNITION INSTALLATION INSTRUCTIONS

Soft Touch Rev Control PN 8728

Note: This Soft Touch Rev Control, PN 8728, is designed for inductive style ignition systems only. It cannot be used with an MSD Ignition Control!

Parts Included:

- 1 - Soft Touch Rev Control
- 4 - RPM Modules, 3,000, 6,000, 7,000, 8,000
- 4 - Wire Splicers
- 4 - Self Tapping Screws
- 4 - Wire Insulating Caps
- 4 - Mounting Pads and Sleeves

WARNING: During installation, disconnect the battery cables. When disconnecting the battery, always remove the Negative cable first and install it last.

Note: The RPM limit is set with plug-in rpm modules. If an rpm module is not installed, there will be no rpm limit.

CYLINDER SELECT

The Soft Touch Rev Control comes from MSD programmed for 8-cylinder applications. It can easily be adjusted for operation on other engines by cutting the cylinder select wire loops (Figure 1). If the loops are cut, use the supplied insulating caps to seal the wire ends.

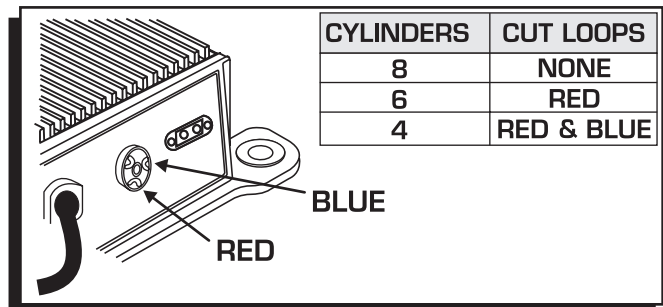

Figure 1 Selecting the Number of Cylinders.

MOUNTING

The Rev Control can be mounted in the engine compartment but away from direct heat sources. It is recommended to mount it where the rpm module is easy to access for rpm adjustments. Make sure all of the wiring reaches their connections. Once a suitable mounting location is determined mark the location of the mounting holes by using the unit as a template. Remove the unit and use an 1/8" bit to drill the holes. Install the supplied mounts and use the four self tapping screws to secure the Control (Figure 2).

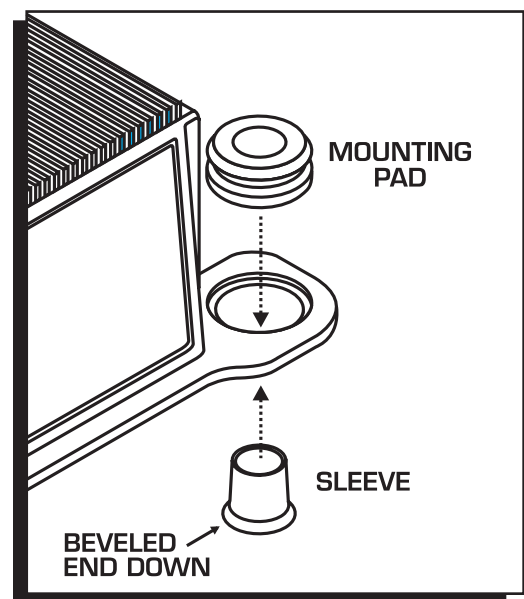

Figure 2 Installing the Vibration Mounts.

WIRING

WARNING: High voltage is present on the coil terminals. Do Not touch the coil terminals or tower when the engine is cranking or running.

Red	Connects to a switched 12 volt source.
Black	Connects to ground on the engine.
Green	Connects to the coil negative (-) terminal.

Trigger Pickup Wires

White	If the distributor is triggered by breaker points or an amplifier, this wire needs to be spliced to its trigger wire.
Violet	If the distributor uses a magnetic pickup, this wire needs to be spliced into the positive mag pickup wire.

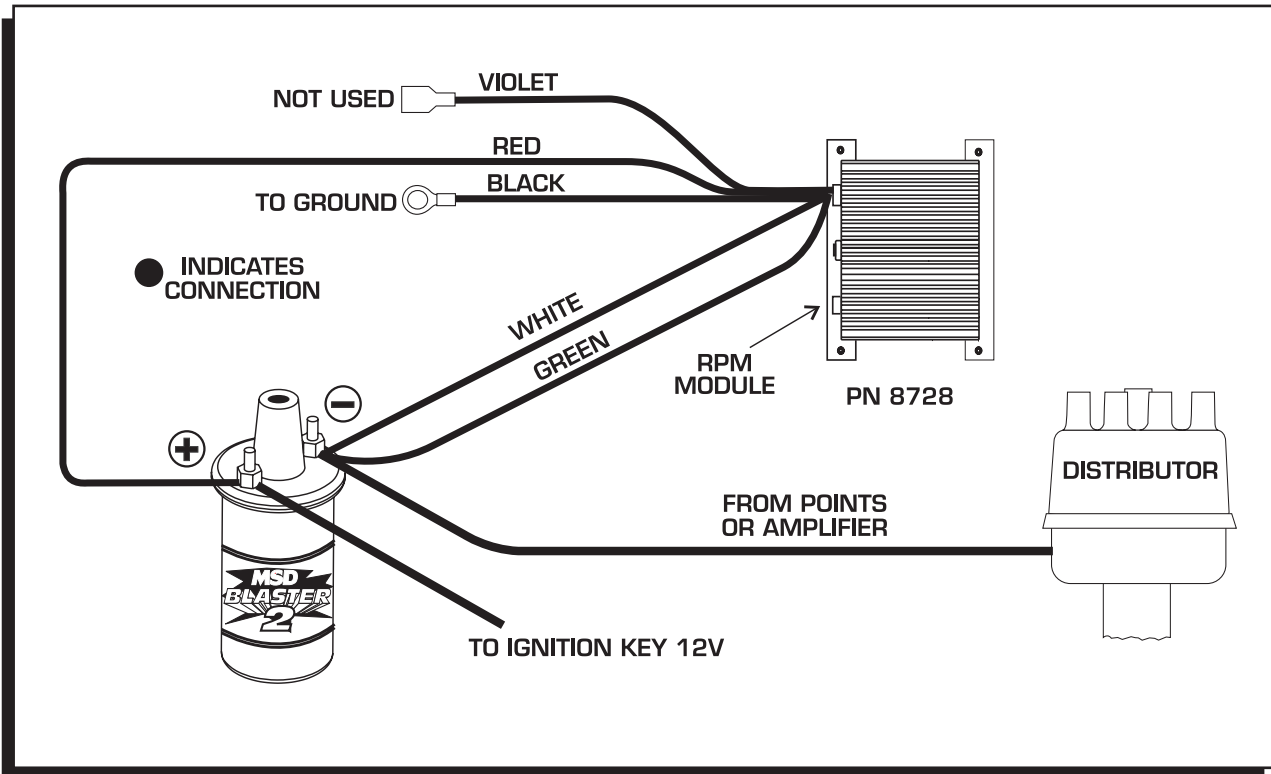

Figure 3 Wiring to a Points/Amplifier Ignition.

Note: The GM Unitized Coil, HEI Distributor was produced with several different modules. If this installation seems to cause a rough limit, try the wiring shown in Figure 5 below.

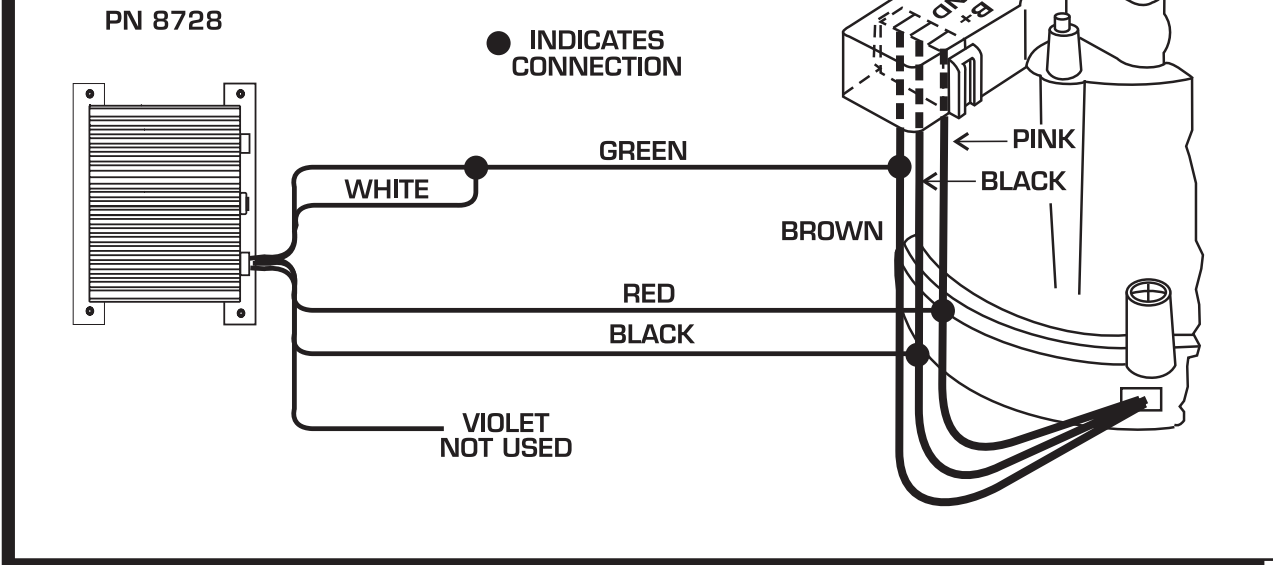

Figure 4 Wiring to a GM HEI Distributor, using the Module.

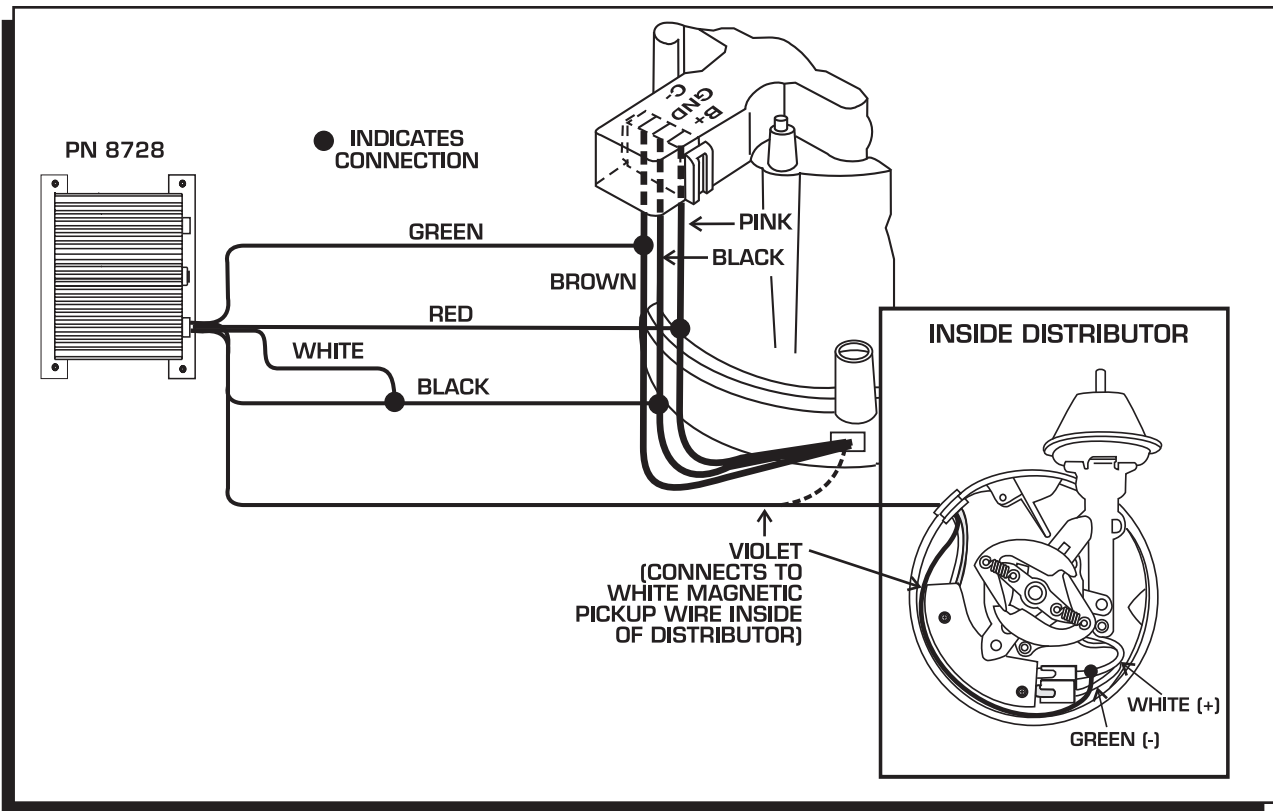

Figure 5 Wiring to a GM HEI Distributor using the Magnetic Pickup.

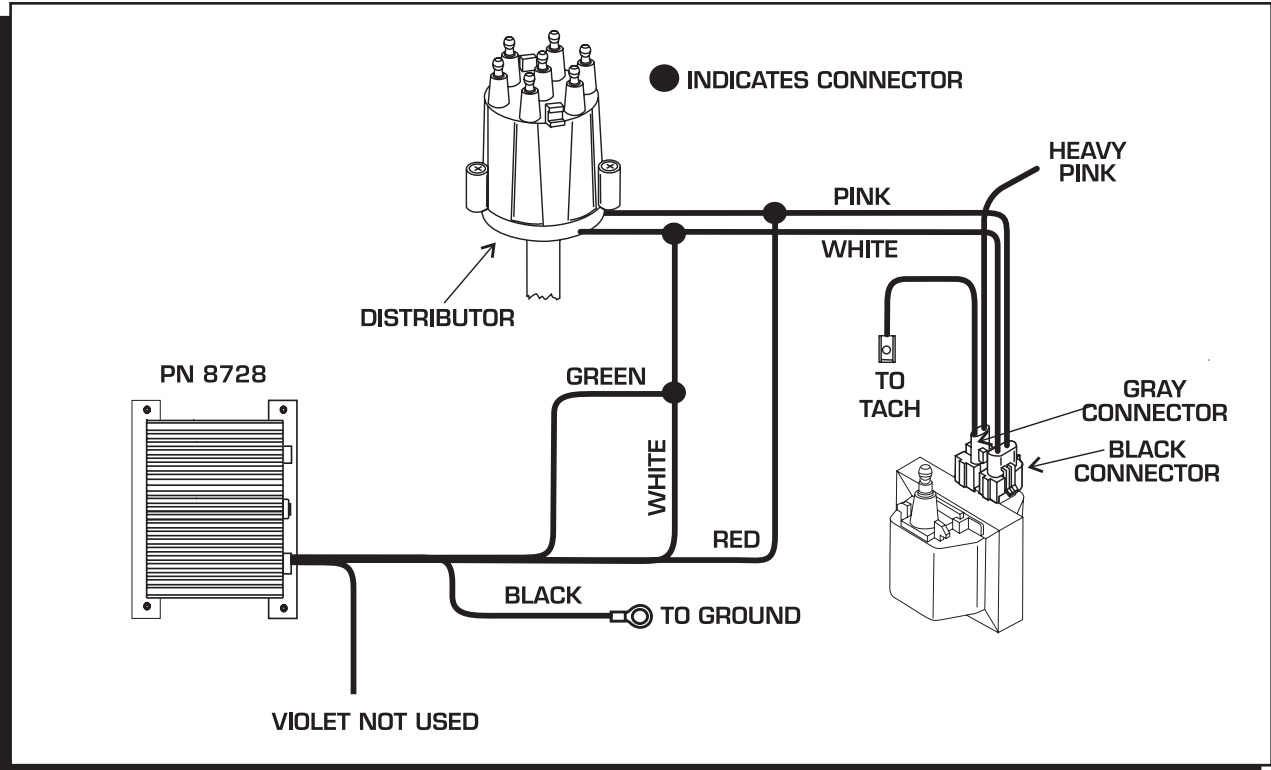

Figure 6 Wiring to a GM Dual Connector Coil System.

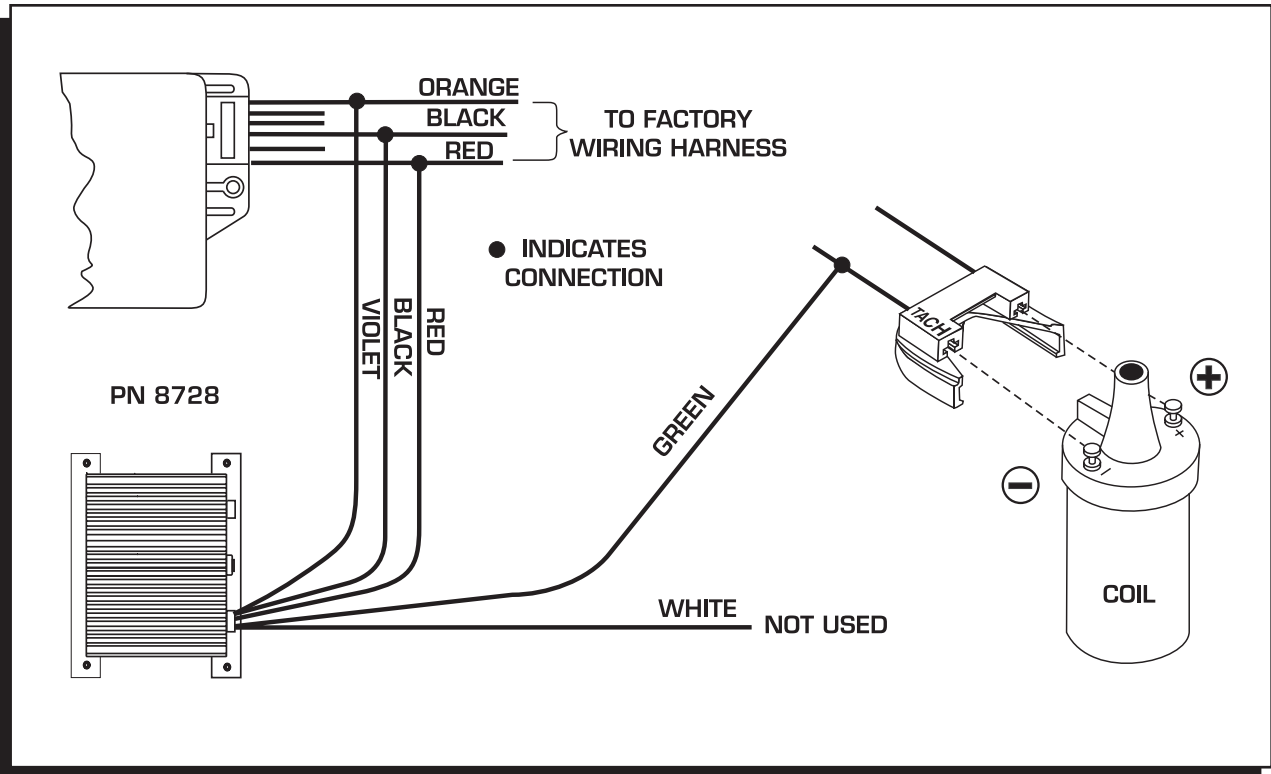

Figure 7 Wiring to a Ford Duraspark Ignition.

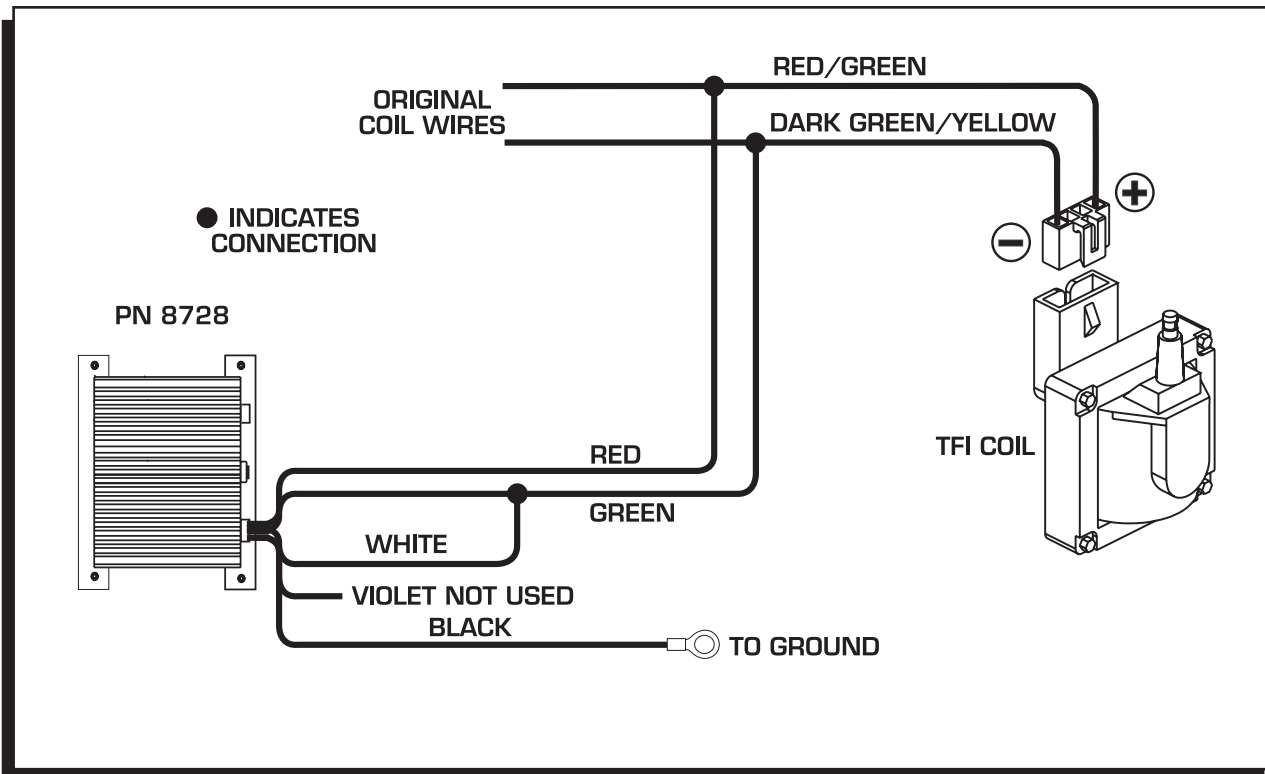

Figure 8 Wiring to a Ford TFI Ignition.

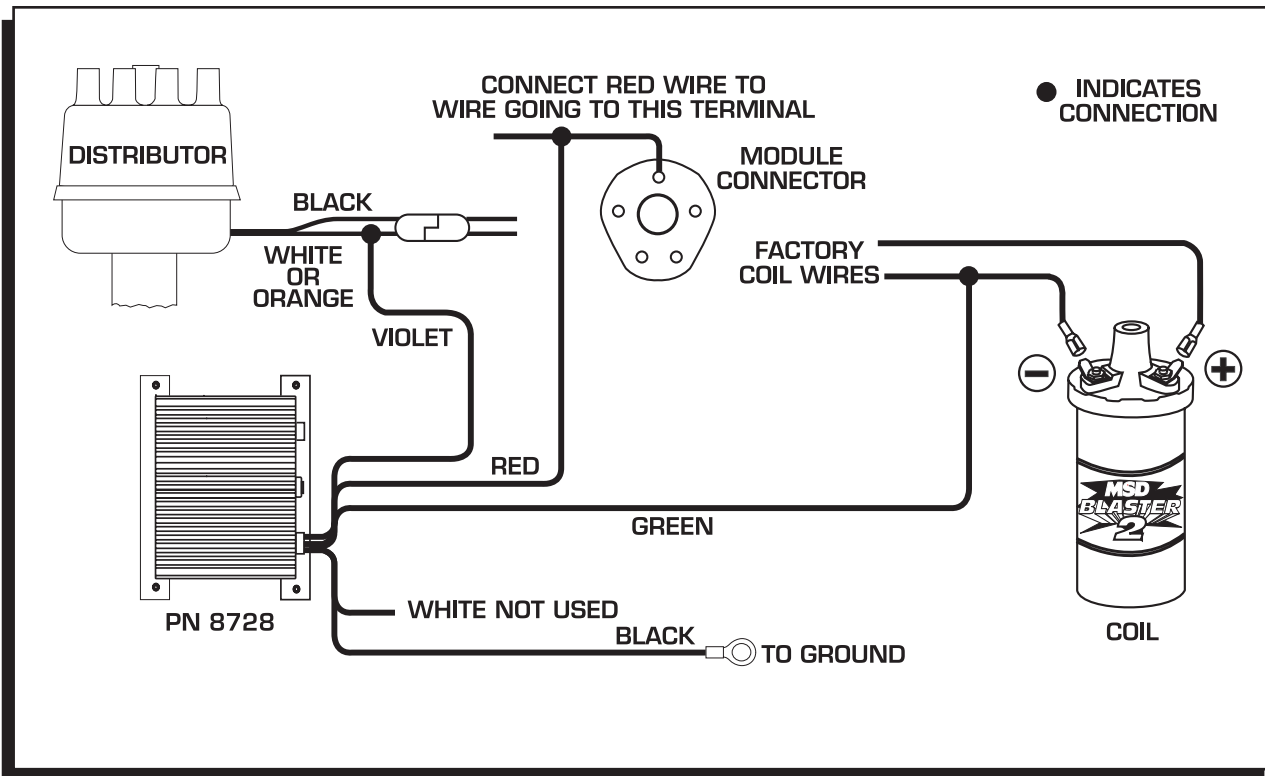

Figure 9 Wiring to a Chrysler Magnetic Pickup.

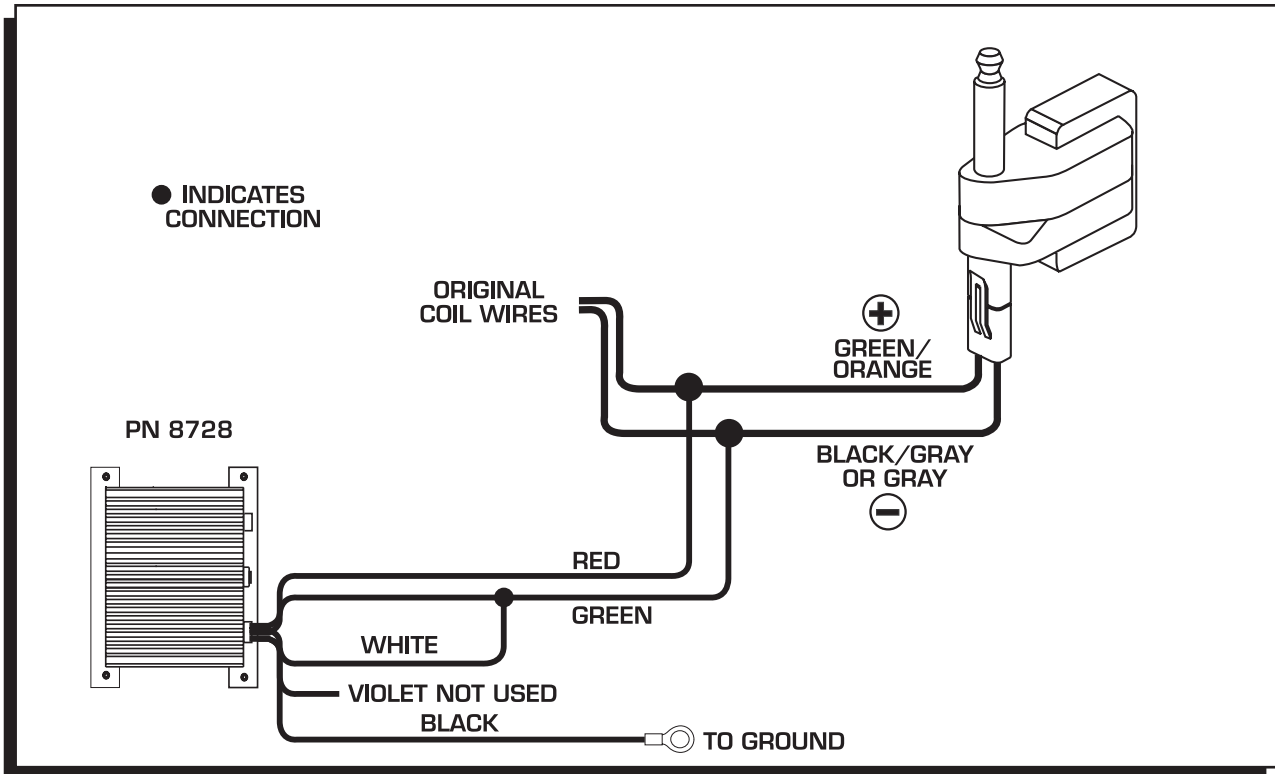

Figure 10 Wiring to a Late Model Dodge Ignition.

RPM MODULE KITS			
EVEN INCREMENTS	ODD INCREMENTS		
3,000-3,800	PN 8743	3,100-3,900	PN 87431
4,000-4,800	PN 8744	4,100-4,900	PN 87441
5,000-5,800	PN 8745	5,100-5,900	PN 87451
6,000-6,800	PN 8746	6,100-6,900	PN 87461
7,000-7,800	PN 8747	7,100-7,900	PN 87471
8,000-8,800	PN 8748	8,100-8,900	PN 87481
9,000-9,800	PN 8749	9,100-9,900	PN 87491
10,000-10,800	PN 8750	10,100-10,900	PN 87501
11,000-11,800	PN 8751	11,100-11,900	PN 87511
12,000-12,800	PN 8752	12,100-12,900	PN 87521
13,000-13,800	PN 8753	13,100-13,900	PN 87531

Kits are supplied with five modules in 200 rpm increments.

RPM MODULE SELECTORS	
3,000-5,200	PN 8670
4,600-6,800	PN 8671
6,000-8,200	PN 8672
7,600-9,800	PN 8673
9,000-11,200	PN 8674
10,600-12,800	PN 8675

RPM Selectors feature a dial that allows you to choose between 12 different rpm limits in 200 rpm