

MSD[®] IGNITION INSTALLATION INSTRUCTIONS

MSD Rotor, PN 8467 Fits MSD Distributors with Caps PN 8433, PN 8431 and other GM Window Style Caps

Parts Included:

1 – Rotor, PN 8467

2 – 5/8" Phillips Head Screws

2 – 3/4" Phillips Head Screws

2 – Belleville Washers

WARNING: Disconnect the battery during installation. When disconnecting the battery, always remove the negative cable first and install it last.

IMPORTANT: There are two different length screws supplied with this rotor. It is important to determine which screws are correct for your application due to clearance of the magnetic pickup.

Remove the cap and rotor and note the rotor screw retainer that is installed on the bottom of the advance plate (Figure 1). There are two styles used; one is a Screw Retainer, the other is a Retainer with a Nut. The Retainer accepts the shorter 5/8" screw while the Nut version accepts the 3/4" screw.

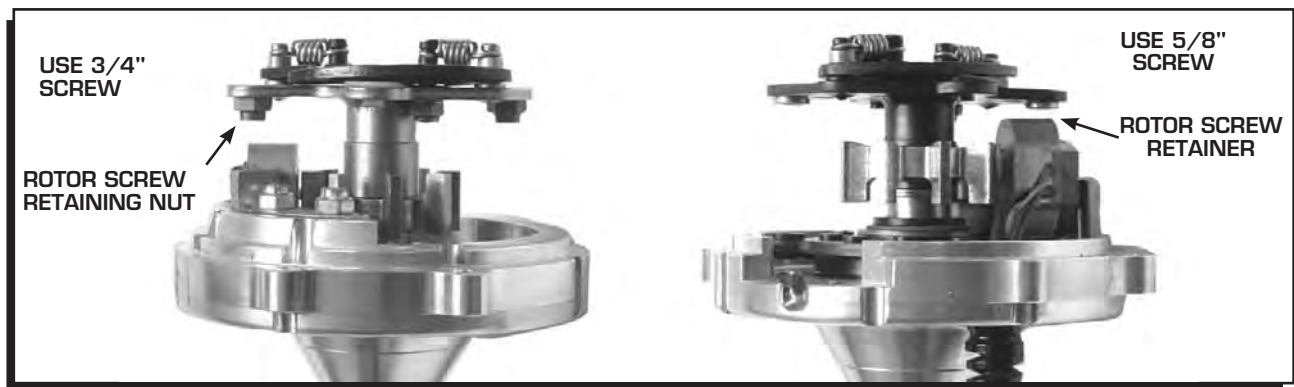

Figure 1 Determining Rotor Screw Length.

Note: It is recommended to install the rotor and check the clearance before reassembling the distributor.

Once the rotor screw length is determined, install the rotor being sure the round and square aligning pegs are lined up correctly. Install the Belleville washers with the **dome facing up** on the screws and tighten the rotor (Figure 2). Install the cap and plug wires.

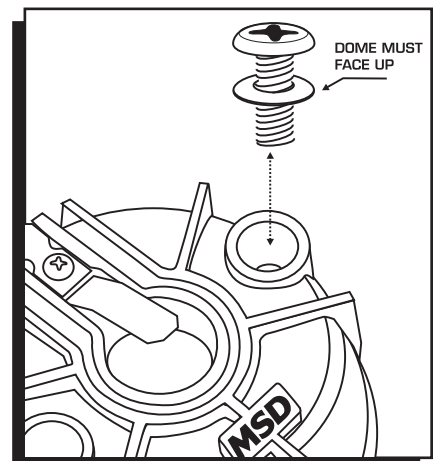

Figure 2 Washer Installation.