

MSD INSTALLATION INSTRUCTIONS

Pro-Billet Late Model Ford Distributors

5.0L, 1986-1993, PN 8456/84563
5.0L, 1994-1995, PN 8455
351W (non-roller cam), PN 8453
351W (with hydraulic roller cam), PN 8452
351W (with hydraulic roller cam), 1994-1995, PN 8451

We at MSD are proud to offer a high quality product at the industries most competitive pricing!

Parts Included:

1 - Distributor	1 - Distributor Cap, Red PN 8408 or Black PN 84083
1 - Gear Lubricant	1 - Rotor, PN 8070
1 - O-Ring	

WARNING: During installation disconnect the battery cables. When disconnecting the battery, always remove negative cable first and install it last.

GEAR INFORMATION

The Pro-Billet PN 8451, PN 8452, PN 8455 and PN 8456 Distributors are designed as a direct replacement for Ford EFI High Output engines and are equipped with a steel gear for the hydraulic roller camshaft.

The PN 8453 model is a replacement for 351W engines with a TFI Ignition module and is supplied with an iron gear (non-roller camshaft).

REMOVAL

1. Remove the existing distributor cap without disconnecting any spark plug wires.
2. With the cap off, turn the engine over until the rotor is aimed at a fixed point on the engine or firewall. Note this position by making a mark (Figure 1).
3. Place the distributor cap back on and note which plug wire the rotor is pointing at. Mark the spark plug wires and remove the cap.
4. Disconnect the connector from the distributor's ignition module.
5. Loosen the distributor hold-down clamp and slide it out of the way.
6. Lift the distributor out of the engine. Note that the rotor rotates as you lift it out. This is due to the helical cut gear and should be taken into consideration when installing the new distributor.

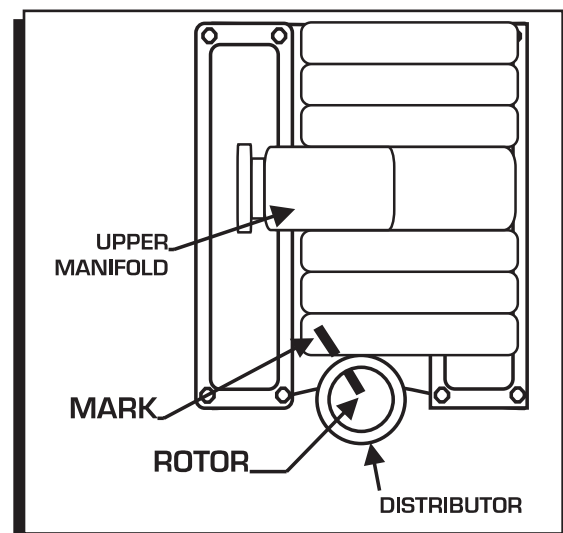

Figure 1 Marking the Distributor Location.

INSTALLATION INSTRUCTIONS

INSTALLATION

1. Install the new o-ring.
2. Remove the cap from the MSD distributor.
3. Apply a liberal amount of the supplied break-in lubricant to the distributor gear.
4. Install the distributor making sure that the rotor comes to rest at the fixed mark. If the distributor will not fully seat you may need to rotate the oil pump shaft.
5. With the rotor in the correct position and the distributor fully seated, install the distributor clamp and tighten it.
6. Connect the wiring harness to the ignition module.
7. Install the distributor cap and install the spark plug wires one at a time to ensure correct location. The firing order of the Ford Mustang 5.0L and the 351W is: 1-3-7-2-6-5-4-8.
Note: This firing order only applies to high output 5.0L engines with a hydraulic roller camshaft.
8. You will need to check the ignition timing to get it to exact specifications. To check the timing you need to disconnect the Spout connector. Follow the recommended procedure which should be outlined on the Emission Specification Decal in the engine compartment.